

Title	Computer System Architecture
Adaption and Typesetting	Dr. Jeetendra Pande, Assistant Professor- School of CS & IT, Uttarakhand Open University, Haldwani
ISBN:	
Author	
Prof. Jatindra Kumar Deka Assistant Professor Department of Computer Science and Engineering, IIT Guwahati	
Acknowledgement	
The University acknowledges with thanks to NPTEL and the author for providing the study material on NPTEL portal under Creative Commons Attribution-NonCommercial-ShareAlike - CC-BY-NC-SA.	
 Uttarakhand Open University, 2020 This work by Uttarakhand Open University is licensed under a Creative Commons Attribution-NonCommercial-ShareAlike - CC-BY-NC-SA. It is attributed to the sources marked in the References, Article Sources and Contributors section.	
Published By: Uttarakhand Open University	

Table of Contents

1.0 Learning Objectives.....	17
1.1 Introduction	17
1.2 Computer Organization and Architecture.....	18
1.3 Basic Computer Model and different units of Computer	20
Check your progress I.....	22
1.4 Basic Working Principle of a Computer	22
1.5 Main Memory Organization.....	25
1.5.1 Memory Instruction	27
Check your progress II	30
1.6 Main Memory Organization: Stored Program.....	31
1.6.1 Central Processing Unit.....	32
1.6.2 The Main Memory Unit.....	32
1.6.3 Input Output Device	33
Check your progress III	33
1.7 Summary.....	34
1.8 Model Questions.....	34
Answers to Check your progress I.....	35
Answers to Check your progress II	35
Answers to Check your progress III.....	35
2.0 Learning Objectives.....	36
2.1 Binary Number System	36
2.2 Representation of Unsigned Integers.....	37
Check your progress I.....	39

2.3 Signed Integer.....	40
2.4 Representation of signed integer	40
2.4.1 Signed magnitude form	40
2.4.2 The concept of complement	41
2.4.2.1 Diminished Radix Complement	41
2.4.2.2 Radix Complement.....	41
2.4.3 Representation of Signed integer in 1's complement form.....	42
2.4.4 Representation of Signed integer in 2's complement form.....	42
2.5 Representation of Real Number	43
2.5.1 Fixed-point representation.....	44
2.5.2 Floating-point representation.....	44
2.5.2.1 IEEE standard floating-point format	45
2.6 Representation of Character	45
Check your progress II	46
2.7 Summary.....	46
2.8 Model Questions.....	47
Answers to Check your progress I.....	47
Answers to Check your progress II	48
Learning Objectives.....	49
3.1 A Brief History of Computer Architecture.....	49
3.2 Generation: The Brief History of Computer Architecture.....	49
3.2.1 First Generation (1940-1950): Vacuum Tube	49
3.2.2 Second Generation (1950-1964): Transistors.....	50
3.2.3 Third Generation (1964-1974): Integrated Circuits (IC).....	50

3.2.4 Fourth Generation (1974-Present): Very Large-Scale Integration (VLSI) / Ultra Large Scale Integration (ULSI)	50
3.3 Evolution of Instruction Sets	51
Check your progress I.....	52
3.4 A Brief History of Computer Organization.....	52
3.5 The history of Computer Organization.....	53
3.5.1 The advance of microprocessor (Intel).....	53
3.5.2 Evolution of Memory	54
3.5.3 Major buses and their features.....	54
3.5.4 Major ports and connectors/interface	54
Check your progress II	55
3.6 Summary.....	55
3.7 Model Questions.....	56
Answers to Check your progress I.....	56
Answers to Check your progress II	56
4.0 Learning Objectives.....	57
4.1 Introduction	57
4.2 Arithmetic Circuit.....	61
4.2.1 Binary Adder	61
4.2.2 Full Adder.....	62
4.2.3 Binary Subtractor.....	64
4.2.4 Multiplication	66
Check your progress I.....	67
4.3 Implemental issue of some operations	68

4.4 Binary Multiplier, Hardware Implementation	69
Check your progress II	71
4.5 Summary.....	72
4.6 Model Questions.....	72
Answers to Check your progress I.....	73
Answers to Check your progress II	73
5.0 Learning Objectives.....	74
5.1 Concept of memory	74
5.1.1 Register	75
5.1.2 Cache Memory	75
5.1.3 Main Memory	75
5.1.4 Magnetic Disk	75
5.1.5 Removable Media.....	76
5.1.6 Main Memory	76
Check your progress I.....	79
5.2 Binary Storage Cell	79
5.2.1 One-bit Binary Cell (BC)	80
5.2.1.1 Dynamic Ram (DRAM)	81
5.2.2.2 Static RAM (SRAM).....	82
5.2.2.3 SRAM Versus DRAM.....	83
5.3 Internal Organization of Memory Chips	83
Check your progress II	91
5.4 Summary.....	91
5.5 Model Questions.....	93

Answers to Check your progress I.....	93
Answers to Check your progress II	93
6.0 Learning Objectives.....	94
6.1 Cache Memory	94
6.2 Operation of Cache Memory	95
6.3 Mapping Functions.....	97
6.3.1 Direct Mapping Technique.....	98
6.3.2 Associated Mapping Technique	99
6.3.3 Block-Set-Associative Mapping Technique.....	100
Check your progress I.....	102
6.4 Replacement Algorithms	102
6.4.1 Least Recently Used (LRU) Replacement policy	102
6.4.2 First In First Out (FIFO) replacement policy	103
6.4.3 Random replacement policy	104
6.5 Summary.....	104
6.6 Model Questions.....	104
Answers to Check your progress I.....	105
7.0 Learning Objectives.....	106
7.1 Main Memory	106
7.2 Memory Management	109
7.2.1 What is swapping?.....	110
7.2.2 Partitioning	110
7.2.2.1 Fixed sized partitions.....	110
7.2.2.2 Variable size Partition	111

Check your progress I.....	114
7.3 Summary.....	114
7.4 Model Questions.....	115
Answers to Check your progress I.....	115
8.0 Learning Objectives.....	116
8.1 Paging.....	116
8.2 Virtual Memory.....	118
Check your progress I.....	120
8.3 Address Translation.....	121
8.3.1 Inverted page table structures.....	122
8.3.2 Translation Lookaside Buffer (TLB).....	123
Check your progress II.....	125
8.4 Summary.....	125
8.5 Model Questions.....	126
Answers to Check your progress I.....	127
Answers to Check your progress II.....	128
9.0 Learning Objectives.....	129
9.1 Addressing Modes.....	129
9.1.1 Immediate Addressing.....	130
9.1.2 Direct Addressing.....	131
9.1.3 Indirect Addressing.....	131
9.1.4 Register Addressing.....	132
9.1.5 Register Indirect Addressing.....	133
9.1.6 Displacement Addressing.....	134

9.1.6.1 Relative Addressing.....	135
9.1.6.2 Base-Register Addressing.....	135
9.1.6.3 Indexing	135
9.6.1.4 Stack Addressing	136
Check your progress I.....	137
9.2 Machine Instruction.....	137
9.3 Instruction Representation.....	138
9.4 Instruction Types	140
9.4.1 Data Processing:	140
9.4.2 Data Storage:	140
9.4.3 Data Movement:	140
9.4.4 Control:	140
9.5 Number of Addresses	141
9.6 Instruction Set Design	141
9.7 Types of Operands.....	142
9.8 Types of Operations	142
9.8.1 Data Transfer	143
9.8.2 Arithmetic.....	144
9.8.3 Logical.....	144
9.8.4 Conversion.....	145
9.8.5 Input/Output	145
9.8.6 System Control	145
9.8.7 Transfer of Control	146
9.8.8 Branch Instruction	146

9.8.9 Skip Instruction	147
9.8.10 Procedure Call Instruction	147
9.9 Instruction Format	149
9.9.1 Instruction Length	150
9.9.2 Allocation of Bits	151
Check your progress II	154
9.10 Summary.....	154
9.11 Model Questions.....	155
Answers to Check your progress I.....	156
Answers to Check your progress II	156
10.0 Learning Objectives.....	157
10.1 Introduction to CPU	157
10.2 Register Organization.....	159
10.2.1 User-visible Registers.....	159
10.3 CPU Register Organization	160
10.3.1 Processor Status Word.....	161
10.4 Concept of Program Execution.....	162
Check your progress I.....	164
10.5 Processor Organization.....	165
10.6 Storing a word into memory	168
10.7 Register Transfer Operation	169
10.7.1 Performing the arithmetic or logic operation	170
10.8 Multiple Bus Organization	171
10.9 Execution of a Complete Instructions	174

10.10 Branching	177
Answers to Check your progress II	179
10.11 Summary.....	179
10.12 Model Questions.....	180
Answers to Check your progress I.....	181
Answers to Check your progress II	182
11.0 Learning Objectives.....	183
11.1 Design of Control Unit	183
11.2 Hardwired Control.....	183
11.2.1 Control Unit Organization.....	185
11.3 Programmable Logic Array	191
Check your progress I.....	192
11.4 Microprogrammed Control.....	192
10.4.1 Control Word (CW).....	193
11.5 Grouping of control signals	201
11.6 Microprogram Sequencing	206
11.6.1 Design Consideration	207
11.6.2 Sequencing Techniques	208
11.6.2.1 Two Address fields.....	208
11.6.2.2 Single address field.....	209
11.6.2.3 Variable format.....	210
11.6.3 Address Generation	211
Check your progress II	211
11.7 Summary.....	212

11.8 Model Questions.....	213
Answers to Check your progress I.....	213
Answers to Check your progress II	214
12.0 Learning Objectives.....	215
12.1 Input/Output Organization.....	215
12.1.1 Input/Output Modules	216
12.1.2 Control & timings.....	216
12.1.3 Processor & Device Communication	217
12.2 Input / Output Subsystem	220
12.3 Input/Output Port.....	222
Check your progress I.....	224
12.4 Programmed I/O	225
12.4.1 I/O Commands.....	225
12.5 Interrupt driven I/O.....	226
12.5.1 Interrupt Processing.....	227
12.5.2 Return from Interrupt	228
12.5.3 Design Issues for Interrupt	230
12.5.4 Device Identification	230
12.5.4.1 Multiple Interrupts Lines	230
12.5.4.2 Software Poll	231
12.5.4.3 Daisy Chain	231
12.5.4.4 Bus Arbitration	232
12.5.5 Handling multiple interrupts.....	232
12.5.6 Interrupt Nesting.....	234

12.6 Direct Memory Access	234
12.6.1 Single bus, detached DMA - I/O configuration.....	238
12.6.2 Single bus, Integrated DMA - I/O configuration.....	238
12.6.3 Using separate I/O bus.....	239
Check your progress II	240
12.7 Summary.....	240
12.8 Model Questions.....	241
Answers to Check your progress I.....	242
Answers to Check your progress II	242
13.0 Learning Objectives.....	243
13.1 Buses.....	243
13.1.1 Synchronous Bus	244
13.1.1.1 Multiple Cycle Transfer	245
13.1.2 Asynchronous Bus.....	246
Check your progress I.....	248
13.2 External Memory	248
13.2.1 Magnetic Disk	249
13.2.1.1 Physical characteristics of disk.....	251
13.2.1.2 Organization and accessing of data on a disk.....	252
13.2.1.3 Disk Operation.....	254
13.3 Disk Performance Parameter	255
13.3.1 Issues with disks	257
13.3.2 Data Striping.....	257
13.3.3 Redundancy	258

13.3.4 RAID levels	258
13.3.4.1 RAID Level 0: Nonredundant	258
13.3.4.2 RAID Level 1: Mirrored.....	259
13.3.4.3 RAID Level 2	259
13.3.4.4 RAID level 3.....	260
13.2.4.5 RAID level 4.....	260
13.2.4.6 RAID level 5.....	261
13.3.4.7 RAID level 6.....	261
Check your progress II	261
13.4 Summary.....	262
13.5 Model Questions.....	263
Answers to Check your progress I.....	263
Answers to Check your progress II	264
14.0 Learning Objectives.....	265
14.1 Introduction	265
14.1.1 Operations.....	266
14.1.2 Operands	268
14.1.3 Procedure Call	268
14.1.4 Implications	268
14.2 Characteristics of Reduced Instruction Set Architecture.....	270
14.2.1 One machine instruction per machine cycle.....	270
14.2.2 Register –to– register operations	271
14.2.3 Simple Addressing Modes.....	271
14.2.4 Simple Instruction Format	271

Check your progress I.....	271
14.3 Design Issues of RISC.....	272
14.3.1 The use of a large register file.....	272
14.3.2 Register Window.....	272
14.3.3 Global Variables.....	276
14.3.4 Compiler based Register Optimization.....	276
14.4 Large Register file versus cache.....	278
Check your progress II.....	278
14.5 Summary.....	279
14.6 Model Questions.....	280
Answers to Check your progress I.....	280
Answers to Check your progress II.....	280
15.0 Learning Objectives.....	281
15.1 Introduction to Pipeline Processor.....	281
15.2 Performance Issues.....	285
Check your progress I.....	292
15.3 Branching.....	293
Check your progress II.....	302
15.4 Summary.....	303
15.5 Model Questions.....	303
Answers to Check your progress I.....	304
Answers to Check your progress II.....	304
16.0 Learning Objectives.....	305
16.1 Parallel Processing.....	305

16.2 Interconnection Networks.....	312
Check your progress I.....	322
16.3 Cache Coherence	322
Check your progress II	327
16.4 Summary.....	328
16.5 Model Questions.....	329
Answers to Check your progress I.....	330
Answers to Check your progress II	330
Reference	331

INTRODUCTION TO COMPUTER SYSTEM

1.0 Learning Objectives

After the completion of the following unit, the learner shall be able to:

- Differentiate between computer organization and computer architecture;
- Define basic computer model and its different units;
- Explain various types of semiconductor memories;
- Define basic working principle of a Computer;
- Explain Von Neumann Stored Program Concept;
- Define Main Memory Organization;

1.1 Introduction

The basic functional units of computer are made of electronics circuit and it works with electrical signal. We provide input to the computer in form of electrical signal and get the output in form of electrical signal. There are two basic types of electrical signals, namely, analog and digital. The analog signals are continuous in nature and digital signals are discrete in nature. The electronic device that works with continuous signals is known as analog device and the electronic device that works with discrete signals is known as digital device. In present days most of the computers are digital in nature and we will deal with Digital Computer in this course.

Computer is a digital device, which works on two levels of signal. We say these two levels of signal as High and Low. The High-level signal basically corresponds to some high-level signal (say 5 Volt or 12 Volt) and Low-level signal basically corresponds to Low-level signal (say 0 Volt). This is one convention, which is known as positive logic. There are others convention also like negative logic.

Since Computer is a digital electronic device, we have to deal with two kinds of electrical signals. But while designing a new computer system or understanding the working principle of computer, it is always difficult to write or work with 0V or 5V.

To make it convenient for understanding, we use some logical value, say,

LOW (L) - will represent 0V and

HIGH (H) - will represent 5V

Computer is used to solve mainly numerical problems. Again, it is not convenient to work with symbolic representation. For that purpose, we move to numeric representation. In this convention, we use 0 to represent LOW and 1 to represent HIGH.

0 means LOW

1 means HIGH

To know about the working principle of computer, we use two numeric symbols only namely 0 and 1. All the functionalities of computer can be captured with 0 and 1 and its theoretical background corresponds to two valued Boolean algebra.

With the symbol 0 and 1, we have a mathematical system, which is known as binary number system. Basically, binary number system is used to represent the information and manipulation of information in computer. This information is basically strings of 0s and 1s.

The smallest unit of information that is represented in computer is known as Bit (Binary Digit), which is either 0 or 1. Four bits together is known as Nibble, and Eight bits together is known as Byte.

1.2 Computer Organization and Architecture

Computer technology has made incredible improvement in the past half century. In the early part of computer evolution, there were no stored-program computer, the computational power was less and on the top of it the size of the computer was a very huge one.

Today, a personal computer has more computational power, more main memory, more disk storage, smaller in size and it is available in affordable cost.

This rapid rate of improvement has come both from advances in the technology used to build computers and from innovation in computer design. In this course we will mainly deal with the innovation in computer design.

The task that the computer designer handles is a complex one: Determine what attributes are important for a new machine, then design a machine to maximize performance while staying within cost constraints.

This task has many aspects, including instruction set design, functional organization, logic design, and implementation.

While looking for the task for computer design, both the terms computer organization and computer architecture come into picture.

It is difficult to give precise definition for the terms Computer Organization and Computer Architecture. But while describing computer system, we come across these terms, and in literature, computer scientists try to make a distinction between these two terms.

Computer architecture refers to those parameters of a computer system that are visible to a programmer or those parameters that have a direct impact on the logical execution of a program. Examples of architectural attributes include the instruction set, the number of bits used to represent different data types, I/O mechanisms, and techniques for addressing memory.

Computer organization refers to the operational units and their interconnections that realize the architectural specifications. Examples of organizational attributes include those hardware details transparent to the programmer, such as control signals, interfaces between the computer and peripherals, and the memory technology used.

In this course we will touch upon all those factors and finally come up with the concept how these attributes contribute to build a complete computer system.

1.3 Basic Computer Model and different units of Computer

The model of a computer can be described by four basic units in high level abstraction which is shown in figure 1.1. These basic units are:

- Central Processor Unit
- Input Unit
- Output Unit
- Memory Unit

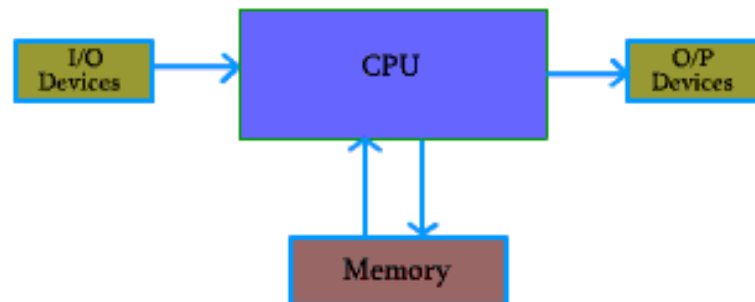

Figure 1.1: Basic Unit of a Computer

A. Central Processor Unit (CPU):

Central processor unit consists of two basic blocks:

- The program control unit has a set of registers and control circuit to generate control signals.
- The execution unit or data processing unit contains a set of registers for storing data and an Arithmetic and Logic Unit (ALU) for execution of arithmetic and logical operations.

In addition, CPU may have some additional registers for temporary storage of data.

B. Input Unit:

With the help of input unit data from outside can be supplied to the computer. Program or data is read into main storage from input device or secondary storage under the control of CPU input instruction.

Example of input devices: Keyboard, Mouse, Hard disk, Floppy disk, CD-ROM drive etc.

C. Output Unit:

With the help of output unit computer results can be provided to the user or it can be stored in storage device permanently for future use. Output data from main storage go to output device under the control of CPU output instructions.

Example of output devices: Printer, Monitor, Plotter, Hard Disk, Floppy Disk etc.

D. Memory Unit:

Memory unit is used to store the data and program. CPU can work with the information stored in memory unit. This memory unit is termed as primary memory or main memory module. These are basically semi conductor memories.

There are two types of semiconductor memories -

- **Volatile Memory** : RAM (Random Access Memory).
- **Non-Volatile Memory** : ROM (Read only Memory), PROM (Programmable ROM) EPROM (Erasable PROM), EEPROM (Electrically Erasable PROM).
- **Secondary Memory** : There is another kind of storage device, apart from primary or main memory, which is known as secondary memory. **Secondary**

memories are non volatile memory and it is used for permanent storage of data and program.

Example of secondary memories:

Hard Disk, Floppy Disk, Magnetic Tape ----- These are magnetic devices,

CD-ROM ----- is optical device

Thumb drive (or pen drive) ----- is semiconductor memory.



Check your progress I

- The electronic device that works with continuous signals is known as _____ device.
- _____ is used to represent the information and manipulation of information in computer.
- Computer _____ refers to those parameters of a computer system that are visible to a programmer or those parameters that have a direct impact on the logical execution of a program.
- Computer _____ refers to the operational units and their interconnections that realize the architectural specifications.
- The execution unit or data processing unit contains a set of registers for storing data and an _____ for execution of arithmetic and logical operations.
- Secondary memories are _____ memory and it is used for permanent storage of data and program.

1.4 Basic Working Principle of a Computer

Before going into the details of working principle of a computer, we will analyze how computers work with the help of a small hypothetical computer.

In this small computer, we do not consider about Input and Output unit. We will consider only CPU and memory module. Assume that somehow, we have stored the program and

data into main memory. We will see how CPU can perform the job depending on the program stored in main memory.

P.S. - Our assumption is that students understand common terms like program, CPU, memory etc. without knowing the exact details.

Consider the Arithmetic and Logic Unit (ALU) of Central Processing Unit:

Consider an ALU which can perform four arithmetic operations and four logical operations. To distinguish between arithmetic and logical operation, we may use a signal line,

0 - in that signal, represents an arithmetic operation and

1 - in that signal, represents a logical operation.

In the similar manner, we need another two signal lines to distinguish between four arithmetic operations. The different operations and their binary code are as follows:

Arithmetic		Logical	
000	ADD	100	OR
001	SUB	101	AND
010	MULT	110	NAND
011	DIV	111	NOR

Consider the part of control unit, its task is to generate the appropriate signal at right moment. There is an instruction decoder in CPU which decodes this information in such a way that computer can perform the desired task

The simple model for the decoder may be considered that there is three input lines to the decoder and correspondingly it generates eight output lines. Depending on input combination only one of the output signals will be generated and it is used to indicate the corresponding operation of ALU.

In our simple model, we use three storage units in CPU,

Two -- for storing the operand and

One -- for storing the results.

These storage units are known as register. But in computer, we need more storage space for proper functioning of the Computer.

Some of them are inside CPU, which are known as register. Other bigger chunk of storage space is known as primary memory or main memory. **The CPU can work with the information available in main memory only.**

To access the data from memory, we need two special registers one is known as **Memory Data Register (MDR)** and the second one is **Memory Address Register (MAR)**.

Data and program is stored in main memory. While executing a program, CPU brings instruction and data from main memory, performs the tasks as per the instruction fetch from the memory. After completion of operation, CPU stores the result back into the memory.

In next section, we discuss about memory organization for our small machine.

1.5 Main Memory Organization

Main memory unit is the storage unit, there are several location for storing information in the main memory module.

The capacity of a memory module is specified by the number of memory location and the information stored in each location.

A memory module of capacity 16 X 4 indicates that, there are 16 location in the memory module and in each location, we can store 4 bit of information.

We have to know how to indicate or point to a specific memory location. This is done by address of the memory location.

We need two operation to work with memory.

READ Operation: This operation is to retrieve the data from memory and bring it to CPU register

WRITE Operation: This operation is to store the data to a memory location from CPU register

We need some mechanism to distinguish these two operations READ and WRITE.

With the help of one signal line, we can differentiate these two operations. If the content of this signal line is

0, we say that we will do a READ operation; and if it is

1, then it is a WRITE operation.

To transfer the data from CPU to memory module and vice-versa, we need some connection. This is termed as **DATA BUS**.

The size of the data bus indicates how many bit we can transfer at a time. Size of data bus is mainly specified by the data storage capacity of each location of memory module.

We have to resolve the issues how to specify a particular memory location where we want to store our data or from where we want to retrieve the data.

This can be done by the memory address. Each location can be specified with the help of a binary address.

If we use 4 signal lines, we have 16 different combinations in these four lines, provided we use two signal values only (say 0 and 1).

To distinguish 16 location, we need four signal lines. These signal lines use to identify a memory location is termed as **ADDRESS BUS**. Size of address bus depends on the memory size. For a memory module of capacity of 2^n location, we need n address lines, that is, an address bus of size n .

We use an address decoder to decode the address that are present in address bus

As for example, consider a memory module of 16 location and each location can store 4 bit of information.

The size of address bus is 4 bit and the size of the data bus is 4 bits

The size of address decoder is 4 X 16.

There is a control signal named R/W.

If $R/W = 0$, we perform a READ operation, and
if $R/W = 1$, we perform a WRITE operation

If the contents of address bus is 0101 and contents of data bus is 1100 and $R/W = 1$, then 1100 will be written in location 5.

If the contents of address bus is 1011 and $R/W=0$, then the contents of location 1011 will be placed in data bus.

In next section, we will explain how to perform memory access operation in our small hypothetical computer.

1.5.1 Memory Instruction

We need some more instruction to work with the computer. Apart from the instruction needed to perform task inside CPU, we need some more instructions for data transfer from main memory to CPU and vice versa.

In our hypothetical machine, we use three signal lines to identify a particular instruction. If we want to include more instruction, we need additional signal lines.

Instruction	Code	Meaning
1000	LDAI imm	Load register A with data that is given in the program
1001	LDAA addr	Load register A with data from memory location addr
1010	LDBI imm	Load register B with data
1011	LDBA addr	Load register B with data from memory location addr
1100	STC addr	Store the value of register C in memory location addr
1101	HALT	Stop the execution
1110	NOP	No operation
1111	NOP	No operation

With this additional signal line, we can go up to 16 instructions. When the signal of this new line is 0, it will indicate the ALU operation. For signal value equal to 1, it will indicate 8 new instructions. So, we can design 8 new memory access instructions.

We have added 6 new instructions. Still two codes are unused, which can be used for other purposes. We show it as **NOP** means No Operation. We have seen that for ALU operation, instruction decoder generated the signal for appropriate ALU operation.

Apart from that we need many more signals for proper functioning of the computer. Therefore, we need a module, which is known as control unit, and it is a part of CPU. The control unit is responsible to generate the appropriate signal. As for example, for LDAI instruction, control unit must generate a signal which enables the register A to store in data into register A.

One major task is to design the control unit to generate the appropriate signal at appropriate time for the proper functioning of the computer. Consider a simple problem to add two numbers and store the result in memory, say we want to add 7 to 5. To solve this problem in computer, we have to write a computer program. The program is machine specific, and it is related to the instruction set of the machine. For our hypothetical machine, the program is as follows:

Instruction	Binary	HEX	Memory Location
LDAI 5	1000 0101	8 5	(0, 1)
LDBI 7	1010 0111	A 7	(2, 3)
ADD	0000	0	(4)
STC 15	1100 1111	C F	(5, 6)
HALT	1101	D	(7)

Consider another example, say that the first number is stored in memory location 13 and the second data is stored in memory location 14. Write a program to Add the contents of memory location 13 and 14 and store the result in memory location 15.

Instruction	Binary	HEX	Memory Location
LDAA 13	1000 0101	8 5	(0, 1)
LDBA 14	1010 0111	A 7	(2, 3)
ADD	0000	0	(4)
STC 15	1100 1111	C F	(5, 6)
HALT	1101	D	(7)

Consider another example, say that the first number is stored in memory location 13 and the second data is stored in memory location 14. Write a program to Add the contents of memory location 13 and 14 and store the result in memory location 15.

Instruction	Binary	HEX	Memory Location
LDAA 13	1000 0101	8 5	(0, 1)
LDBA 14	1010 0111	A 7	(2, 3)
ADD	0000	0	(4)
STC 15	1100 1111	C F	(5, 6)
HALT	1101	D	(7)

One question still remains unanswered: How to store the program or data to main memory. Once we put the program and data in main memory, then only CPU can execute the program. For that we need some more instructions.

We need some instructions to perform the input tasks. These instructions are responsible to provide the input data from input devices and store them in main memory. For example, instructions are needed to take input from keyboard.

We need some other instructions to perform the output tasks. These instructions are responsible to provide the result to output devices. For example, instructions are needed to send the result to printer.

We have seen that number of instructions that can be provided in a computer depends on the signal lines that are used to provide the instruction, which is basically the size of the storage devices of the computer.

For uniformity, we use same size for all storage space, which are known as register. If we work with a 16-bit machine, total instructions that can be implemented is 2^{16} .

The model that we have described here is known as *Von Neumann Stored Program Concept*. First, we have to store all the instruction of a program in main memory, and CPU can work with the contents that are stored in main memory. Instructions are executed one after another.

We have explained the concept of computer in very high-level abstraction by omitting most of the details.

 **Check your progress II**

➤ What is the capacity of the following memory?

Address	
000000000000	Instruction (Program)
000000000001	
000000000010	Operands (Data)
000000000011	
.....	
.....	
111111111111	

➤ NOP means_____.

1.6 Main Memory Organization: Stored Program

The present-day digital computers are based on stored-program concept introduced by Von Neumann. In this stored-program concept, programs and data are stored in separate storage unit called memories.

Central Processing Unit, the main component of computer can work with the information stored in storage unit only.

In 1946, Von Neumann and his colleagues began the design of a stored-program computer at the Institute for Advanced Studies in Princeton. This computer is referred as the IAS computer.

The structure of IAS computer is shown in Figure 1.2.

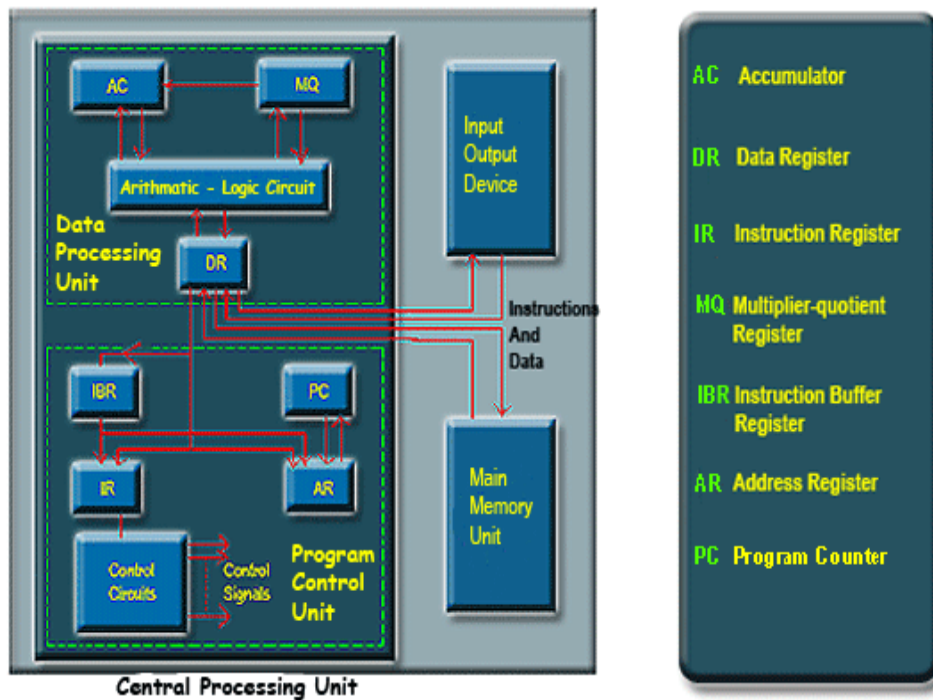

Figure 1.2: Structure of a first-generation computer: IAS

The IAS computer is having three basic units:

- The Central Processing Unit (CPU).
- The Main Memory Unit.
- The Input/Output Device.

1.6.1 Central Processing Unit

This is the main unit of computer, which is responsible to perform all the operations. The CPU of the IAS computer consists of a data processing unit and a program control unit.

The data processing unit contains a high-speed register intended for temporary storage of instructions, memory addresses and data. The main action specified by instructions are performed by the arithmetic-logic circuits of the data processing unit.

The control circuits in the program control unit are responsible for fetching instructions, decoding opcodes, controlling the information movements correctly through the system, and providing proper control signals for all CPU actions.

1.6.2 The Main Memory Unit

It is used for storing programs and data. The memory locations of memory unit is uniquely specified by the memory address of the location. $M(X)$ is used to indicate the location of the memory unit M with address X .

The data transfer between memory unit and CPU takes place with the help of data register DR. When CPU wants to read some information from memory unit, the information first brings to DR, and after that it goes to appropriate position. Similarly, data to be stored to memory must put into DR first, and then it is stored to appropriate location in the memory unit.

The address of the memory location that is used during memory read and memory write operations are stored in the memory register AR.

The information fetched from the memory is an operand of an instruction, then it is moved from DR to data processing unit (either to AC or MQ). If it is an operand, then it is moved to program control unit (either to IR or IBR).

Two additional registers for the temporary storage of operands and results are included in data processing units: the accumulator AC and the multiplier-quotient register MQ.

Two instructions are fetched simultaneously from M and transferred to the program control unit. The instruction that is not to be executed immediately is placed in the instruction buffer register IBR. The opcode of the other instruction is placed in the instruction register IR where it is decoded.

In the decoding phase, the control circuits generate the required control signals to perform the specified operation in the instruction. The program counter (PC) is used to store the address of the next instruction to be fetched from memory.

1.6.3 Input Output Device

Input devices are used to put the information into computer. With the help of input devices we can store information in memory so that CPU can use it. Program or data is read into main memory from input device or secondary storage under the control of CPU input instruction.

Output devices are used to output the information from computer. If some results are evaluated by computer and it is stored in computer, then with the help of output devices, we can present it to the user. Output data from the main memory go to output device under the control of CPU output instruction.



Check your progress III

- The data transfer between memory unit and CPU takes place with the help of_____.
- The _____ is used to store the address of the next instruction to be fetched from memory.

1.7 Summary

1. The smallest unit of information that is represented in computer is known as Bit (Binary Digit)
2. Four bits together is known as Nibble.
3. Eight bits together is known as Byte.
4. There are two basic types of electrical signals, namely, analog and digital.
5. The analog signals are continuous in nature and digital signals are discrete in nature.
6. Memory unit is used to store the data and program.
7. The CPU can work with the information available in main memory only.
8. The capacity of a memory module is specified by the number of memory location and the information stored in each location.
9. To transfer the data from CPU to memory module and vice-versa, we need some connection. This is termed as DATA BUS.
10. The control unit is responsible to generate the appropriate signal.
11. The control circuits in the program control unit are responsible for fetching instructions, decoding opcodes, controlling the information movements correctly through the system, and providing proper control signals for all CPU actions.
12. Input devices are used to put the information into computer.
13. Output devices are used to output the information from computer.

1.8 Model Questions

1. Differentiate between an analog and a digital signal.
2. Explain the Basic Computer Model and its different units?
3. How the capacity of a memory module is specified?
4. Explain Von Neumann Stored Program Concept.
5. Explain the structure of IAS computer with the help of a diagram.
6. What are the functions of programmed control unit?



Answers to Check your progress I

- Analog
- binary number system
- architecture
- organization
- Arithmetic and Logic Unit (ALU)
- non-volatile



Answers to Check your progress II

- (4096 X 16) as the memory have 4096 unique address locations and each location can store 16-bit of data.
- No Operation



Answers to Check your progress III

- Data Register
- Program Counter

NUMBER SYSTEM AND REPRESENTATION

2.0 Learning Objectives

- After the completion of this unit, the learner shall be able to:
- Convert a given decimal number to a binary number;
- Convert a given binary number to a decimal number;
- Define Octal and hexadecimal numbers;
- Explain the representation of unsigned integers;
- Explain the representation of signed integers;
- Represent a negative number in signed-magnitude form;
- Represent a negative number in 1's complement form;
- Represent a negative number in 2's complement form;
- Explain the representation of Real Numbers;
- Explain IEEE standard floating-point format;
- Define the Representation of Character in ASCII, EBCDIC and UNICODE format;

2.1 Binary Number System

We have already mentioned that computer can handle with two type of signals, therefore, to represent any information in computer, we have to take help of these two signals. These two signals correspond to two levels of electrical signals, and symbolically we represent them as 0 and 1.

In our day to day activities for arithmetic, we use the *Decimal Number System*. The decimal number system is said to be of base, or radix 10, because it uses ten digits and the coefficients are multiplied by power of 10.

A decimal number such as 5273 represents a quantity equal to 5 thousand plus 2 hundred, plus 7 tens, plus 3 units. The thousands, hundreds, etc. are powers of 10 implied by the position of the coefficients. To be more precise, 5273 should be written as:

$$5 \times 10^3 + 2 \times 10^2 + 7 \times 10^1 + 3 \times 10^0$$

However, the convention is to write only the coefficient and from their position deduce the necessary power of 10.

In decimal number system, we need 10 different symbols. But in computer we have provision to represent only two symbols. So directly we can not use decimal number system in computer arithmetic.

For computer arithmetic we use **binary number system**. The binary number system uses two symbols to represent the number and these two symbols are 0 and 1.

The binary number system is said to be of base 2 or radix 2, because it uses two digits and the coefficients are multiplied by power of 2.

The binary number 110011 represents the quantity equal to:

$$1 \times 2^5 + 1 \times 2^4 + 0 \times 2^3 + 0 \times 2^2 + 1 \times 2^1 + 1 \times 2^0 = 51 \text{ (in decimal)}$$

We can use binary number system for computer arithmetic.

2.2 Representation of Unsigned Integers

Any integer can be stored in computer in binary form. As for example: The binary equivalent of integer 107 is 1101011, so 1101011 are stored to represent 107.

What is the size of Integer that can be stored in a Computer? It depends on the word size of the Computer. If we are working with 8-bit computer, then we can use only 8 bits to represent the number. The eight bit computer means the storage organization for data is 8 bits.

In case of 8-bit numbers, the minimum number that can be stored in computer is 00000000 (0) and maximum number is 11111111 (255) (if we are working with natural numbers).

So, the domain of number is restricted by the storage capacity of the computer. Also, it is related to number system; above range is for natural numbers.

In general, for *n-bit* number, the range for natural number is from 0 to $2^n - 1$

Any arithmetic operation can be performed with the help of binary number system. Consider the following two examples, where decimal and binary additions are shown side by side.

01101000	104
00110001	49
-----	-----
10011001	153

In the above example, the result is an 8-bit number, as it can be stored in the 8-bit computer, so we get the correct results.

10000001	129
10101010	178
-----	-----
100101011	307

In the above example, the result is a 9-bit number, but we can store only 8 bits, and the most significant bit (MSB) cannot be stored.

The result of this addition will be stored as (00101011) which is 43 and it is not the desired result. Since we cannot store the complete result of an operation, and it is known as the overflow case.

The smallest unit of information is known as **BIT (BInary digiT)**.

The binary number 110011 consists of 6 bits and it represents:

$$1 \times 2^5 + 1 \times 2^4 + 0 \times 2^3 + 0 \times 2^2 + 1 \times 2^1 + 1 \times 2^0$$

For an *n-bit* number the coefficient is - a_j multiplied by 2^j where, $0 \leq j < n$.

The coefficient $a_{(n-1)}$ is multiplied by $2^{(n-1)}$ and it is known as most significant bit (MSB). The coefficient a_0 is multiplied by 2^0 and it is known as least significant bit (LSB).

For our convenient, while writing in paper, we may take help of other number systems like octal and hexadecimal. It will reduce the burden of writing long strings of 0s and 1s.

Octal Number: The octal number system is said to be of base, or radix 8, because it uses 8 digits and the coefficients are multiplied by power of 8. Eight digits used in octal system are: 0, 1, 2, 3, 4, 5, 6 and 7.

Hexadecimal number : The hexadecimal number system is said to be of base, or radix 16, because it uses 16 symbols and the coefficients are multiplied by power of 16. Sixteen digits used in hexadecimal system are: 0, 1, 2, 3, 4, 5, 6, 7, 8, 9, A, B, C, D, E and F. Consider the following addition example:

Binary	Octal	Hexadecimal	Decimal
01101000	150	68	104
00111010	072	3A	58
-----	-----	-----	-----
10100010	242	A2	162



Check your progress I

- The smallest unit of information a computer can understand and process is known as a ____.
- A string of eight 0s and 1s is called a _____.
- A computer works on a _____ number system.
- Hexadecimal number system has _____ base.
- Convert $(89)_{10} = (\dots\dots\dots)_2$

2.3 Signed Integer

We know that for n -bit number, the range for natural number is from 0 to 2^n-1 .

For n -bit, we have all together 2^n different combination, and we use these different combinations to represent 2^n numbers, which ranges from 0 to $2^n -1$.

If we want to include the negative number, naturally, the range will decrease. Half of the combinations are used for positive number and other half is used for negative number.

For n -bit representation, the range is from $(- 2^{n-1})$ to $(+ 2^{n-1})$.

For example, if we consider 8-bit number, then range for natural number is from 0 to 255; but for signed integer the range is from -127 to +127.

2.4 Representation of signed integer

We know that for n -bit number, the range for natural number is from 0 to $2^n -1$.

There are **three different schemes** to represent negative number:

- **Signed-Magnitude form.**
- **1's complement form.**
- **2's complement form.**

2.4.1 Signed magnitude form

In signed-magnitude form, one particular bit is used to indicate the sign of the number, whether it is a positive number or a negative number. Other bits are used to represent the magnitude of the number.

For an n -bit number, one bit is used to indicate the signed information and remaining $(n-1)$ bits are used to represent the magnitude. Therefore, the range is from $(- 2^{n-1})$ to $(+ 2^{n-1})$.

Generally, Most Significant Bit (MSB) is used to indicate the sign and it is termed as signed bit. 0 in signed bit indicates positive number and 1 in signed bit indicates negative number.

For example, 01011001 represents + 169, and
 11011001 represents - 169

What is 00000000 and 10000000 in signed magnitude form?

2.4.2 The concept of complement

The concept of complements is used to represent signed number. Consider a number system of *base-r* or *radix-r*. There are two types of complements,

- The radix complement or the *r*'s complement.
- The diminished radix complement or the $(r - 1)$'s complement.

2.4.2.1 Diminished Radix Complement

Given a number N in base r having n digits, the $(r - 1)$'s complement of N is defined as $(r^n - 1) - N$. For decimal numbers, $r = 10$ and $r - 1 = 9$, so the 9's complement of N is $(10^n - 1) - N$.

e.g., 9's complement of 5642 is $9999 - 5642 = 4357$.

2.4.2.2 Radix Complement

The r 's complement of an n -digit number in base r is defined as $r^n - N$ for $N \neq 0$ and 0 for $N = 0$.

r 's complement is obtained by adding 1 to the $(r - 1)$'s complement, since

$$(r^n - N) = [(r^n - 1) - N] + 1.$$

e.g., 10's complement of 5642 is 9's complement of 5642 + 1, i.e., 4357 + 1 = 4358
 e.g., 2's complement of 1010 is 1's complement of 1010 + 1, i.e., 0101 + 1 = 0110.

2.4.3 Representation of Signed integer in 1's complement form

Consider the eight-bit number 01011100, 1's complements of this number is 10100011. If we perform the following addition:

0 1 0 1 1 1 0 0
1 0 1 0 0 0 1 1

1 1 1 1 1 1 1 1

If we add 1 to the number, the result is 100000000.

Since we are considering an eight bit number, so the 9th bit (MSB) of the result cannot be stored. Therefore, the final result is 00000000.

Since the addition of two number is 0, so one can be treated as the negative of the other number. So, 1's complement can be used to represent negative number.

2.4.4 Representation of Signed integer in 2's complement form

Consider the eight-bit number 01011100, 2's complements of this number is 10100100. If we perform the following addition:

0 1 0 1 1 1 0 0
1 0 1 0 0 0 1 1

1 0 0 0 0 0 0 0

Since we are considering an eight bit number, so the 9th bit (MSB) of the result can not be stored. Therefore, the final result is 00000000.

Since the addition of two number is 0, so one can be treated as the negative of the other number. So, 2's complement can be used to represent negative number.

Decimal	2's Complement	1's complement	Signed Magnitude
+7	0111	0111	0111
+6	0110	0110	0110
+5	0101	0101	0101
+4	0100	0100	0100
+3	0011	0011	0011
+2	0010	0010	0010
+1	0001	0001	0001
+0	0000	0000	0000
-0	-----	1111	1000
-1	1111	1110	1001
-2	1110	1101	1010
-3	1101	1100	1011
-4	1100	1011	1100
-5	1011	1010	1101
-6	1010	1001	1110
-7	1001	1000	1111
-8	1000	-----	-----

2.5 Representation of Real Number

Binary representation of 41.6875 is 101001.1011

Therefore any real number can be converted to binary number system There are **two schemes** to represent real number :

- Fixed-point representation
- Floating-point representation

2.5.1 Fixed-point representation

Binary representation of 41.6875 is 101001.1011

To store this number, we have to store **two information**,

- the part before decimal point and
- the part after decimal point.

This is known as fixed-point representation where the position of decimal point is fixed and number of bits before and after decimal point are also predefined.

If we use 16 bits before decimal point and 7 bits after decimal point, in signed magnitude form, the range is

$$-2^{16} - 1 \text{ to } +2^{16} - 1 \text{ and the precision is } 2^{(-7)}$$

One bit is required for sign information, so the total size of the number is 24 bits

$$(1(\text{sign}) + 16(\text{before decimal point}) + 7(\text{after decimal point})).$$

2.5.2 Floating-point representation

In this representation, numbers are represented by a mantissa comprising the significant digits and an exponent part of Radix R. The format is:

$$\textit{mantissa} * R^{\textit{exponent}}$$

Numbers are often normalized, such that the decimal point is placed to the right of the **first non zero digit**.

For example, the decimal number, 5236 is equivalent to $.5236 * 10^4$

To store this number in floating point representation, we store 5236 in mantissa part and 4 in exponent part.

2.5.2.1 IEEE standard floating-point format

IEEE has proposed two standards for representing floating-point number:

- Single precision
- Double precision

Single Precision:



S: sign bit: 0 denoted + and 1 denotes -

E: 8-bit excess -27 exponent

M: 23-bit mantissa

Double Precision:

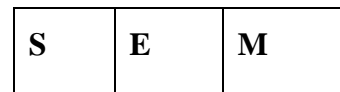

S: sign bit: 0 denoted + and 1 denotes -

E: 11-bit excess -1023 exponent

M: 52-bit mantissa

2.6 Representation of Character

Since we are working with 0's and 1's only, to represent character in computer we use strings of 0's and 1's only.

To represent character, we are using some coding scheme, which is nothing but a mapping function. Some of standard coding schemes are: **ASCII**, **EBCDIC**, **UNICODE**.

ASCII: American Standard Code for Information Interchange. It uses a 7-bit code. All together we have 128 combinations of 7 bits and we can represent 128 character. As for example 65 = 1000001 represents character 'A'.

EBCDIC: Extended Binary Coded Decimal Interchange Code. It uses 8-bit code and we can represent 256 character.

UNICODE: It is used to capture most of the languages of the world. It uses 16-bit. Unicode provides a unique number for every character, no matter what the platform, no matter what the program, no matter what the language. The Unicode Standard has been adopted by such industry leaders as Apple, HP, IBM, JustSystem, Microsoft, Oracle, SAP, Sun, Sybase, Unisys and many others.



Check your progress II

- i. EBCDIC that is used in computing stands for_____.
- ii. ASCII stands for_____.
- iii. In EBCDIC code, maximum possible characters set size is _____.

2.7 Summary

1. Decimal Numbers: 10 Symbols {0,1,2,3,4,5,6,7,8,9}, Base or Radix is 10.
2. Binary Numbers: 2 Symbols {0,1}, Base or Radix is 2.
3. The binary number system is positional where each binary digit has a weight based upon its position relative to the least significant bit (LSB).
4. Octal Numbers: Symbols {0,1,2,3,4,5,6,7}, Base or Radix is 8.
5. Hexadecimal Numbers: 16 Symbols {0,1,2,3,4,5,6,7,8,9,A,B,C,D,E,F}, Base is 16.
6. Many applications have to deal with non-numerical data.
 - a. Characters and strings
 - b. There must be a standard mechanism to represent alphanumeric and other characters in memory.
7. Three standards in use:
 - a. Extended Binary Coded Decimal Interchange Code(EBCDIC)

- i. Used in older IBM machines
 - ii. American Standard Code for Information Interchange(ASCII)
 - iii. Most widely used today
- b. UNICODE
 - i. Used to represent all international characters.
 - ii. Used by Java

2.8 Model Questions

1. What is overflow case?
2. Write the procedure to convert a decimal number to a binary number.
3. Write a short note on the following:
 - a. ASCII coding scheme
 - b. EBCDIC coding scheme
 - c. UNICODE coding scheme
4. What are the three possible approaches to represent signed integers? Explain each of them in detail.
5. Convert the following:
 - a. $(66)_{10} = (\dots\dots\dots)_2$
 - b. $(101011)_2 = (\dots\dots)_{10}$
 - c. $(1011\ 0100\ 0011)_2 = (\dots\dots\dots\dots\dots)_{16}$
 - d. $(3A5)_{16} = (\dots\dots\dots\dots\dots)_2$
 - e. Convert 54.45 into its binary equivalent.



Answers to Check your progress I

- Bit
- Byte
- Binary
- 16

➤ 1011001



Answers to Check your progress II

- i. Extended of BCD interchange code
- ii. American Standard Code for Information Interchange
- iii. 256

BRIEF HISTORY OF COMPUTER EVOLUTION

Learning Objectives

After the completion of this unit, the learner shall be able to:

- Know the brief history of Computer evolution;
- Define the features and technologies of various generations of computer;
- Know the brief History of Computer Organization;

3.1 A Brief History of Computer Architecture

Computer Architecture is the field of study of selecting and interconnecting hardware components to create computers that satisfy functional performance and cost goals. It refers to those attributes of the computer system that are visible to a programmer and have a direct effect on the execution of a program.

Computer Architecture concerns Machine Organization, interfaces, application, technology, measurement & simulation that Includes:

- Instruction set
- Data formats
- Principle of Operation (formal description of every operation)
- Features (organization of programmable storage, registers used, interrupts mechanism, etc.)

In short, it is the combination of Instruction Set Architecture, Machine Organization and the related hardware.

3.2 Generation: The Brief History of Computer Architecture

3.2.1 First Generation (1940-1950): Vacuum Tube

- **ENIAC [1945]:** Designed by Mauchly & Echart, built by US army to calculate trajectories for ballistic shells during Worls War II. Around 18000 vacuum tubes

and 1500 relays were used to build ENIAC, and it was programmed by manually setting switches

- **UNIVAC [1950]:** the first commercial computer
- **John Von Neumann architecture:** Goldstine and Von Neumann took the idea of ENIAC and developed concept of storing a program in the memory. Known as the Von Neumann's architecture and has been the basis for virtually every machine designed since then.

Features:

- Electron emitting devices
- Data and programs are stored in a single read-write memory
- Memory contents are addressable by location, regardless of the content itself
- Machine language/Assemble language
- Sequential execution

3.2.2 Second Generation (1950-1964): Transistors

- William Shockley, John Bardeen, and Walter Brattain invent the **transistor** that reduce size of computers and improve reliability. Vacuum tubes have been replaced by transistors.
- **First operating Systems:** handled one program at a time
- **On-off switches** controlled by electronically.
- **High level languages**
- **Floating point arithmetic**

3.2.3 Third Generation (1964-1974): Integrated Circuits (IC)

- **Microprocessor chips** combines thousands of transistors, entire circuit on one computer chip.
- **Semiconductor memory**
- **Multiple computer models** with different performance characteristics
- The **size** of computers has been reduced drastically

3.2.4 Fourth Generation (1974-Present): Very Large-Scale Integration (VLSI) / Ultra Large Scale Integration (ULSI)

- **Combines** millions of transistors
- **Single-chip processor** and the single-board computer emerged
- Creation of the **Personal Computer (PC)**
- Use of **data communications**
- Massively **parallel machine**

3.3 Evolution of Instruction Sets

Instruction Set Architecture (ISA) Abstract interface between the Hardware and lowest-level Software

- 1950: Single Accumulator: EDSAC
- 1953: Accumulator plus Index Registers: Manchester Mark I, IBM 700 series
- Separation of programming Model from implementation:
 - 1963: High-level language Based: B5000
 - 1964: Concept of a Family: IBM 360
- General Purpose Register Machines:
 - 1963-1976: **Load/Store Architecture**: CDC 6600, Cray 1
 - 1977-1980: **CISC** - Complex Instruction Sets computer: Vax, Intel 432
 - 1987: **RISC**: Reduced Instruction Set Computer: Mips, Sparc, HP-PA, IBM RS6000

Typical RISC:

- Simple, no complex addressing
- Constant length instruction, 32-bit fixed format
- Large register file
- Hard wired control unit, no need for micro programming
- Just about every opposites of CISC

Major advances in computer architecture are typically associated with landmark instruction set designs. Computer architecture's definition itself has been through bit changes. The following are the main concern for computer architecture through different times:

- 1930-1950: Computer arithmetic
 - Microprogramming
 - Pipelining
 - Cache
 - Timeshared multiprocessor
- 1960: Operating system support, especially memory management
 - Virtual memory
- 1970-1980: **Instruction Set Design**, especially for compilers; **Vector processing** and **shared memory multiprocessors**
 - RISC
- 1990s: Design of CPU, memory system, I/O system, multi-processors, networks

- CC-UMA multiprocessor
- CC-NUMA multiprocessor
- Not-CC-NUMA multiprocessor
- Message-passing multiprocessor
- 2000s: Special purpose architecture, functionally reconfigurable, special considerations for low power/mobile processing, chip multiprocessors, memory systems
 - Massive SIMD
 - Parallel processing multiprocessor

Under a rapidly changing set of forces, computer technology keeps at dramatic change, for example:

- **Processor clock rate** at about 20% increase a year
- **Logic capacity** at about 30% increase a year
- **Memory speed** at about 10% increase a year
- **Memory capacity** at about 60% increase a year
- **Cost per bit** improves about 25% a year
- **The disk capacity** increase at 60% a year.



Check your progress I

1. How many memory locations can be addressed with the help of 8-bit address bus?
2. Give example of input and output devices.

3.4 A Brief History of Computer Organization

If **computer architecture** is a view of the *whole design with the important characteristics* visible to programmer, **computer organization** is *how features are implemented with the specific building blocks* visible to designer, such as control signals, interfaces, memory technology, etc. Computer architecture and organization are closely related, though not exactly the same.

A stored program computer has the following basic units:

- **Processor** -- center for manipulation and control

- **Memory** -- storage for instructions and data for currently executing programs
- **I/O system** -- controller which communicate with "external" devices: secondary memory, display devices, networks
- **Data-path & control** -- collection of parallel wires, transmits data, instructions, or control signal

Computer organization defines the ways in which these components are interconnected and controlled. It is the capabilities and performance characteristics of those principal functional units. Architecture can have a number of organizational implementations, and organization differs between different versions. Such, all **Intel x86** families share the same basic architecture, and **IBM system/370** family share their basic architecture.

3.5 The history of Computer Organization

Computer architecture has progressed four generation: **vacuum tubes, transistors, integrated circuits**, and **VLSI**. Computer organization has also made its historic progression accordingly.

3.5.1 The advance of microprocessor (Intel)

- **1977:** 8080 - the first general purpose microprocessor, 8-bit data path, used in first personal computer
- **1978:** 8086 - with 16 bit, 1MB addressable, instruction cache, prefetch few instructions
- **1980:** 80186 - identical to 8086 with additional reserved interrupt vectors and some very powerful built-in I/O functions.
- **1982:** 80286 - 24 Mbyte addressable memory space, plus instructions
- **1985:** 80386 - 32 bit, new addressing modes and support for multitasking
- **1989 -- 1995:**
 - 80486 - 25, 33, MHz, 1.2 M transistors, 5 stage pipeline, sophisticated powerful cache and instruction pipelining, built in math co-processor.
 - Pentium - 60, 66 MHz, 3.1 M transistor, branch predictor, pipelined floating point, multiple instructions executed in parallel, first superscalar IA-32.
 - PentiumPro - Increased superscalar, register renaming, branch prediction, data flow analysis, and speculative execution

- **1995 -- 1997:** Pentium II - 233, 166, 300 MHz, 7.5 M transistors, first compaction of micro- architecture, MMX technology, graphics video and audio processing.
- **1999:** Pentium III - additional floating point instructions for 3D graphics
- **2000:** Pentium IV - Further floating point and multimedia enhancements

3.5.2 Evolution of Memory

- 1970: **RAM /DRAM**, 4.77 MHz
- 1987: **FPM** - fast page mode DRAM, 20 MHz
- 1995, **EDO** - Extended Data Output, which increases the read cycle between memory and CPU, 20 MHz
- 1997- 1998: **SDRAM** - Synchronous DRAM, which synchronizes itself with the CPU bus and runs at higher clock speeds, PC66 at 66 MHz, PC100 at 100 MHz
- 1999: **RDRAM** - Rambus DRAM, which DRAM with a very high bandwidth, 800 MHz
- 1999-2000: **SDRAM** - PC133 at 133 MHz, DDR at 266 MHz.
- 2001: **EDRAM** - Enhanced DRAM, which is dynamic or power-refreshed RAM, also know as cached DRAM.

3.5.3 Major buses and their features

A bus is a parallel circuit that connects the major components of a computer, allowing the transfer of electric impulses form one connected component to any other.

- **VESA** - Video Electronics Standard Association: 32 bit, relied on the 486 processor to function
- **ISA** - Industry Standard Architecture: 8 bit or 16 bit with width 8 or 16 bits. 8.3 MHz speed, 7.9 or 15.9 bandwidth accordingly.
- **EISA** - Extended Industry Standard Architecture: 32 bits, 8.3 MHz, 31.8 bandwidth, the attempt to compete with IBM's MCA
- **PCI** - Peripheral Component Interconnect: 32 bits, 33 MHz, 127.2 bandwidth
- **PCI-X** - Up to 133 MHz bus speed, 64 bits bandwidth, 1GB/sec throughput
- **AGP** - Accelerated Graphics Port: 32 bits, 66 MHz, 254,3 bandwidth.

3.5.4 Major ports and connectors/interface

- **IDE** - Integrated Drive Electronics, also know as ATA, EIDE, Ultra ATA, Ultra DMA, most widely used interface for hard disks
- **PS/2 port** - mini Din plug with 6 pins for a mouse and keyboard
- **SCSI** - Small Computer System Interface, 80 - 640 Mbs, capable of handling internal/external peripherals

- **Serial Port** - adheres to RS-232c spec, uses DB9 or DB25 connector, capable of 115kb.sec speeds
- **Parallel port** - as know as printer port, enhanced types: ECP- extended capabilities port, EPP - enhanced parallel port
- **USB - universal serial bus**, two types: 1.0 and 2.0, hot plug-and-play, at 12MB/s, up to 127 devices chain. 2.0 data rate is at 480 bits/s.
- **Firewire** - high speed serial port, 400 MB/s, hot plug-and-play, 30 times faster than USB 1.0



Check your progress II

1. _____ is the first general purpose microprocessor, 8-bit data path, used in first personal computer.
2. VESA stands for _____.
3. IDE stands for _____.
4. _____ is a high speed serial port, 400 MB/s, hot plug-and-play, 30 times faster than USB 1.0.

3.6 Summary

1. Computer Architecture is the field of study of selecting and interconnecting hardware components to create computers that satisfy functional performance and cost goals.
2. Computer Architecture refers to those attributes of the computer system that are visible to a programmer and have a direct effect on the execution of a program.
3. Computer organization defines the ways in which these components are interconnected and controlled.
4. A bus is a parallel circuit that connects the major components of a computer, allowing the transfer of electric impulses form one connected component to any other.

3.7 Model Questions

1. Give an example to distinguish computer architecture and computer organization.
2. Define computer architecture.
3. Explain the various units of a stored program computer?
4. What is data bus and address bus?
5. What are the technologies used in the first four generations of the computer?
6. Explain the features of PCI bus.



Answers to Check your progress I

1. Number of memory location that can be addressed by a 8-bit address bus is $2^8 = 256$
2. Input Device : Keyboard, Mouse, Hard disk, Floppy
 Output Device Monitor, Printer, Hard disk, Floppy etc.



Answers to Check your progress II

1. 8080
2. Video Electronics Standard Association
3. Integrated Drive Electronics
4. Firewire

ARITHMETIC LOGIC UNIT

4.0 Learning Objectives

After the completion of this unit, the learner shall be able to:

- Define the functioning of an Arithmetic Logic Unit (ALU);
- Explain the basic operations of ALU that are implemented in hardware level;
- Know the functioning of several logic gates exists in digital logic circuit;
- Design arithmetic circuits like binary adder, binary subtractor, full adder, etc.
- Design a binary multiplier circuit;

4.1 Introduction

ALU is responsible to perform the operation in the computer. The basic operations are implemented in hardware level. ALU is having collection of two types of operations:

- Arithmetic operations
- Logical operations

Consider an ALU having 4 arithmetic operations and 4 logical operation. To identify any one of these four logical operations or four arithmetic operations, two control lines are needed. Also, to identify the any one of these two groups- arithmetic or logical, another control line is needed. So, with the help of three control lines, any one of these eight operations can be identified.

Consider an ALU is having four arithmetic operations. Addition, subtraction, multiplication and division. Also consider that the ALU is having four logical operations: OR, AND, NOT & EX-OR.

We need three control lines to identify any one of these operations. The input combination of these control lines is shown below:

Control line C_2 is used to identify the group: logical or arithmetic, i.e. $C_2=0$: arithmetic operation $C_2 =1$: logical operation. Control lines C_0 and C_1 are used to identify any one of the four operations in a group. One possible combination is given here.

C_1	C_0	Arithmetic $C_2 = 0$	Logical $C_2 = 1$
0	0	Addition	OR
0	1	Subtraction	AND
1	0	Multiplication	NOT
1	1	Division	EX-OR

A 3 X8 decode is used to decode the instruction. The block diagram of the ALU is shown in figure 2.1.

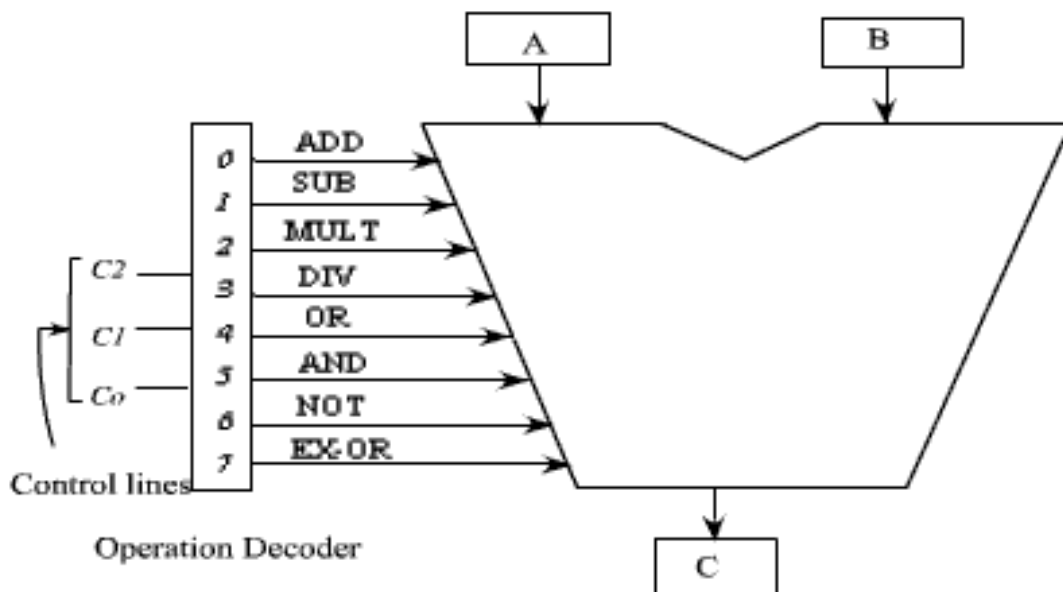

Figure 2.1: Block Diagram of the ALU

The ALU has got two input registers named as A and B and one output storage register, named as C. It performs the operation as:

$$C = A \text{ op } B$$

The input data are stored in A and B, and according to the operation specified in the control lines, the ALU perform the operation and put the result in register C.

As for example, if the contents of controls lines are, 000, then the decoder enables the addition operation and it activates the adder circuit and the addition operation is performed on the data that are available in storage register A and B . After the completion of the operation, the result is stored in register C. We should have some hardware implementations for basic operations. These basic operations can be used to implement some complicated operations which are not feasible to implement directly in hardware. There are several logic gates exists in digital logic circuit. These logic gates can be used to implement the logical operation. Some of the common logic gates are mentioned here.

AND gate: The output is high if both the inputs are high. The AND gate and its truth table is shown in Figure 2.2.

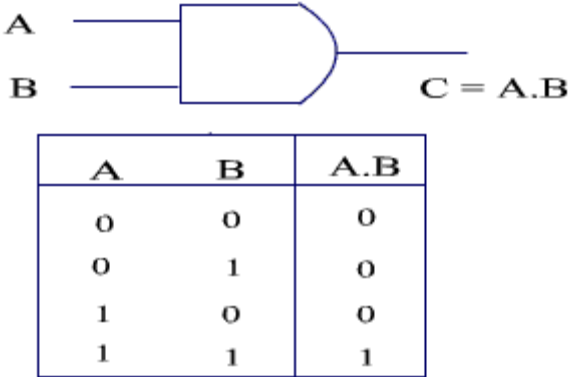
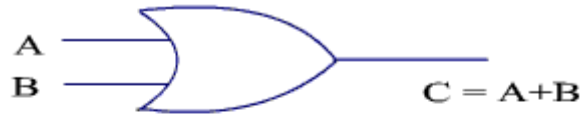

Figure 2.2: AND gate and its truth table.

OR gate: The output is high if any one of the input is high. The OR gate and its truth table is shown in Figure 2.3.



A	B	A+B
0	0	0
0	1	1
1	0	1
1	1	1

Figure 2.3: OR gate and its truth table.

EX-OR gate: The output is high if either of the input is high. The EX-OR gate and its truth table is given in Figure 2.4.

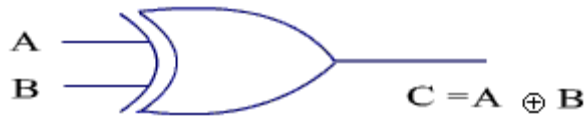

A	B	A ⊕ B
0	0	0
0	1	1
1	0	1
1	1	0

Figure 2.4: EX-OR gate and its truth table.

If we want to construct a circuit which will perform the AND operation on two 4-bit number, the implementation of the 4-bit AND operation is shown in the Figure-2.5.

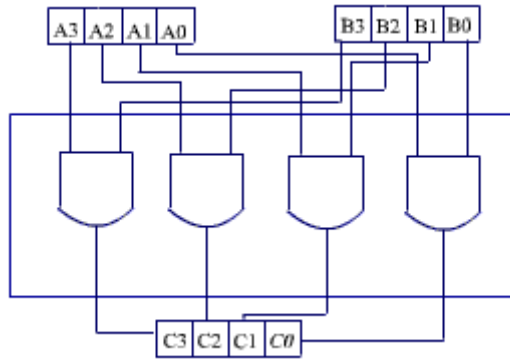

Figure2.5: 4-bit AND operator

4.2 Arithmetic Circuit

4.2.1 Binary Adder

Binary adder is used to add two binary numbers. In general, the adder circuit needs two binary inputs and two binary outputs. The input variables designate the augends and addend bits; The output variables produce the sum and carry. The binary addition operation of single bit is shown in the truth table

X	Y	C	S
0	0	0	0
0	1	0	1
1	0	0	1
1	1	1	0

C: Carry Bit

S: Sum Bit

The simplified sum of products expressions are:

$$S = x'y + xy'$$

$$C = xy$$

The circuit implementation is:

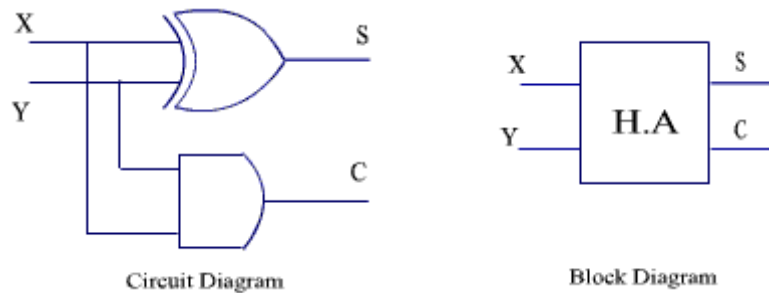

Figure 2.6: Circuit diagram and Block diagram of Half Adder

This circuit can not handle the carry input, so it is termed as **half adder**. The circuit diagram and block diagram of Half Adder is shown in Figure 2.6.

4.2.2 Full Adder

A full adder is a combinational circuit that forms the arithmetic sum of three bits. It consists of three inputs and two outputs. Two of the input variables, denoted by x and y , represent the two bits to be added. The third input Z , represents the carry from the previous lower position. The two outputs are designated by the symbols S for sum and C for carry.

X	Y	Z	C	S
0	0	0	0	0
0	0	1	0	1
0	1	0	0	1
0	1	1	1	0
1	0	0	0	1
1	0	1	1	0
1	1	0	1	0
1	1	1	1	1

The simplified expression for S and C are:

$$\begin{aligned}
 S &= x'y'z + x'yz' + xy'z' + xyz \\
 C &= xy + xz + yz \\
 &= xy + xy'z + x'y z
 \end{aligned}$$

We may rearrange these two expressions as follows:

$$\begin{aligned}
 S &= z \oplus (x \oplus y) \\
 &= z'(xy' + x'y) + z(xy' + x'y) \\
 &= z'(xy' + x'y) + z(xy' + x'y) \\
 &= xy'z' + x'yz' + xyz + x'y z \\
 C &= z(xy' + x'y) + xy = xy'z + x'yz + xy
 \end{aligned}$$

The circuit diagram full adder is shown in the figure.

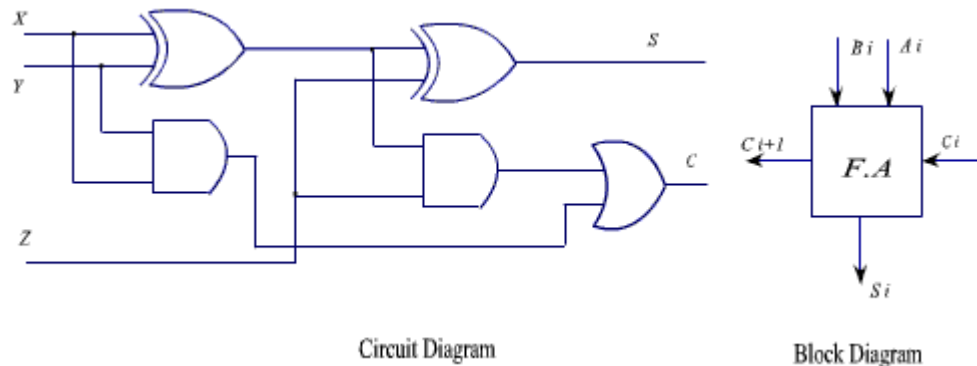

Figure 2.7: Circuit diagram and block diagram of Full Adder

The circuit diagram and block diagram of a Full Adder is shown in the Figure 2.7. n -such single bit full adder blocks are used to make n -bit full adder. To demonstrate the binary addition of four-bit numbers, let us consider a specific example. Consider two binary numbers

$$A = 1001$$

$$B = 0011$$

Subscript	i	3	2	1	0
Input carry	C_i	0	1	1	0
Augend	A_i	1	0	0	1
Addend	B_i	0	0	1	1
Sum	S_i	1	1	0	0
Output Carry	C_{i+1}	0	0	1	1

To get the four bit adder, we have to use 4 full adder block. The carry output the lower bit is used as a carry input to the next higher bit. The circuit of 4-bit adder shown in the Figure 2.8.

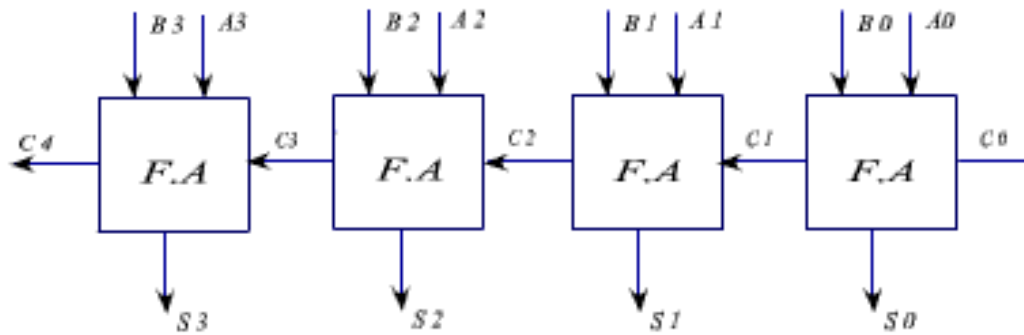

Figure 2.8: A 4-bit adder circuit.

4.2.3 Binary Subtractor

The subtraction operation can be implemented with the help of binary adder circuit, because

$$A - B = A + (-B)$$

We know that 2's complement representation of a number is treated as a negative number of the given number.

We can get the 2's complements of a given number by complementing each bit and adding 1 to it.

The circuit for subtracting $A-B$ consist of an added with inverter placed between each data input B and the corresponding input of the full adder. The input carry C_0 must be equal to 1 when performing subtraction.

The operation thus performed becomes A , plus the 1's complement of B , plus 1. This is equal to A plus 2's complement of B .

With this principle, a single circuit can be used for both addition and subtraction. The 4-bit adder subtractor circuit is shown in the figure. It has got one mode (M) selection input line, which will determine the operation,

If $M=0$, then $A+B$

If $M=1$, then $A - B = A + (-B)$
 $= A + 1\text{'s complement of } B + 1$

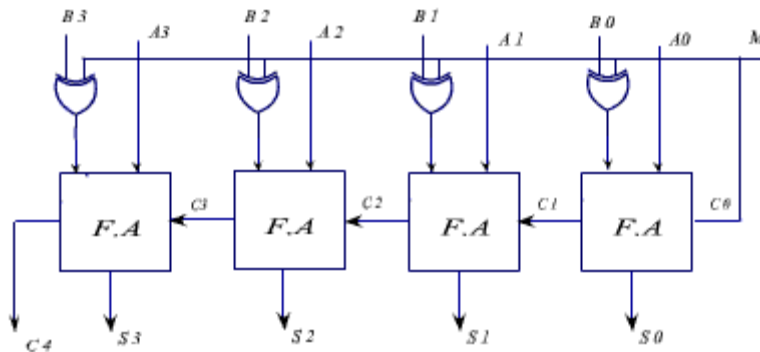

Figure 2.9: 4-bit adder subtractor

The circuit diagram of a 4-bit adder subtractor is shown in the Figure 2.9.

The operation of OR gate:

$$x \oplus 0 = x$$

$$x \oplus 1 = x'$$

$$\text{if } M = 0, \quad B_i \oplus 0 = B_i$$

$$\text{if } M = 1, \quad B_i \oplus 1 = B_i'$$

4.2.4 Multiplication

Multiplication of two numbers in binary representation can be performed by a process of SHIFT and ADD operations. Since the binary number system allows only 0 and 1's, the digit multiplication can be replaced by SHIFT and ADD operation only, because multiplying by 1 gives the number itself and multiplying by 0 produces 0 only.

The multiplication process is illustrated with a numerical example.

$\begin{array}{r} 25 \\ \times 19 \\ \hline 225 \\ 25 \\ \hline 475 \end{array}$	<table style="border: 1px solid black; padding: 5px; width: 100%;"> <tr> <td style="text-align: right;">11001</td> <td>Multiplicand</td> </tr> <tr> <td style="text-align: right;">10011</td> <td>Multiplier</td> </tr> <tr> <td colspan="2"><hr/></td> </tr> <tr> <td style="text-align: right;">11001</td> <td></td> </tr> <tr> <td style="text-align: right;">11001</td> <td></td> </tr> <tr> <td style="text-align: right;">00000</td> <td></td> </tr> <tr> <td style="text-align: right;">00000</td> <td></td> </tr> <tr> <td style="text-align: right;">11001</td> <td></td> </tr> <tr> <td colspan="2"><hr/></td> </tr> <tr> <td style="text-align: right;">111011011</td> <td>Product</td> </tr> </table>	11001	Multiplicand	10011	Multiplier	<hr/>		11001		11001		00000		00000		11001		<hr/>		111011011	Product
11001	Multiplicand																				
10011	Multiplier																				
<hr/>																					
11001																					
11001																					
00000																					
00000																					
11001																					
<hr/>																					
111011011	Product																				

The process consists of looking at successive bits of the multiplier, least significant bit first. If the multiplier bit is a 1, the multiplicand is copied down, otherwise, zeros are copied down. The numbers copied down in successive lines are shifted one position to the left from the previous number. Finally, the numbers are added and their sum forms the product.

When multiplication is implemented in a digital computer, the process is changed slightly. Instead of providing registers to store and add simultaneously as many binary numbers as there are bits in the multiplier, it is convenient to provide an adder for the summation of only two binary numbers and successively accumulate the partial products in a register. It will reduce the requirements of registers. Instead of shifting the multiplicand to the left, the partial product is shifted to right. When the corresponding bit of the multiplier is 0, there is no need to add all zeros to the partial product.

An algorithm to multiply two binary numbers. Consider that the ALU does not provide the multiplication operation, but it is having the addition operation and shifting operation. Then we can write a micro program for multiplication operation and provide the micro program code in memory. When a multiplication operation is encountered, it will execute this micro code to perform the multiplication.



Check your progress I

1. The ALU gives the output of the operations and the output is stored in the _____
 - a. Memory Devices
 - b. Registers
 - c. Flags
 - d. Output Unit
2. ALU is _____?
 - a. Arithmetic Logic Unit
 - b. Array Logic Unit
 - c. Application Logic Unit
 - d. None of above
3. Total number of inputs in a half adder is _____
 - a. 2
 - b. 3
 - c. 4

- d. 1
4. In which operation carry is obtained?
- a. Subtraction
 - b. Addition
 - c. Multiplication
 - d. Both addition and subtraction
5. If A and B are the inputs of a half adder, the sum is given by _____
- a. A AND B
 - b. A OR B
 - c. A XOR B
 - d. A EX-NOR B

4.3 Implemental issue of some operations

The micro code is nothing but the collection of some instructions. ALU must have those operation; otherwise we must have micro code again for those operations which are not supported in ALU.

Consider a situation such that we do not have the multiplication operation in a primitive computer. Is it possible to perform the multiplication? Of course, yes, provided the addition operation is available.

We can perform the multiplication with the help of repeated addition method; for example, if we want to multiply 4 by 5 (4 X 5), then simply add 4 five times to get the result. If it is possible by addition operation, then why we need a multiplication operation. Consider a machine, which can handle 8 bit numbers, then we can represent number from 0 to 255. If we want to multiply 175 X 225, then there will be at least 175 addition operation.

But if we use the multiplication algorithm that involves shifting and addition, it can be done in 8 steps, because we are using an 8-bit machine.

Again, the micro program execution is slightly slower, because we have to access the code from micro controller memory, and memory is a slower device than CPU. It is possible to implement the multiplication algorithm in hardware.

4.4 Binary Multiplier, Hardware Implementation

The block diagram of binary multiplier is shown in the Figure 2.10.

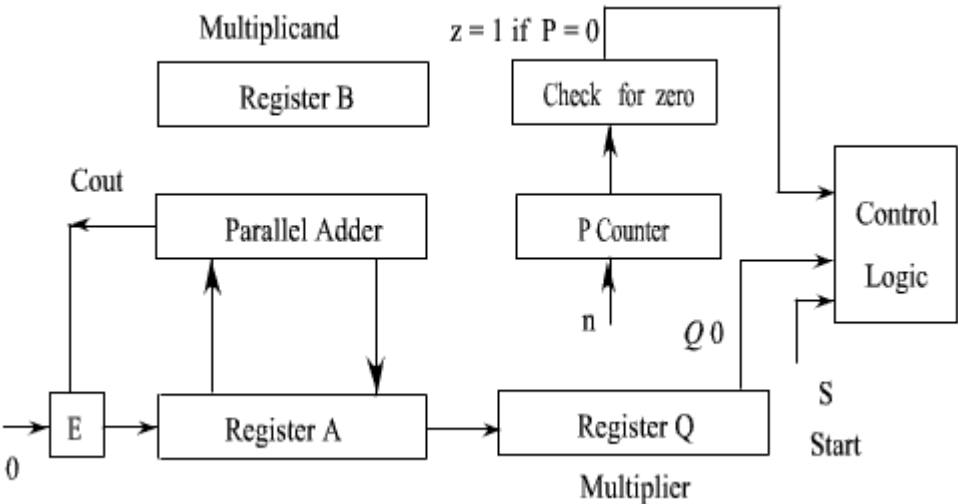

Figure 1.10: Block diagram of binary multiplier

The multiplicand is stored in register B and the multiplier is stored in register Q. The partial product is formed in register A and stored in A and Q

The counter P is initially set to a number equal to the number of bits in the multiplier. The counter is decremented by 1 after forming each partial product. When the content of the counter reaches zero, the product is formed and the process stops.

Initially, the multiplicand is in register B and the multiplier in Q. The register A is reset to 0. The sum of A and B forms a partial product- which is transferred to the EA register.

Both partial product and multiplier are shifted to the right. The least significant bit of A is shifted into the most significant position of Q; and 0 is shifted into E.

After the shift, one bit of the partial product is shifted into Q, pushing the multiplier bits one position to the right.

The right most flip flop in register Q, designated by Q_0 will hold the bit of the multiplier which must be inspected next. If the content of this bit is 0, then it is not required to add the multiplicand, only shifting is needed. If the content of this bit is 1, then both addition and shifting are needed.

After each shifter, value of counter P is decremented and the process continues till the counter value becomes 0. The final result is available in (EAQ) registers combination.

To control the operation, it is required to design the appropriate control logic that is shown in the block diagram. The flow chart of the multiplication operation is given in the Figure 2.11.

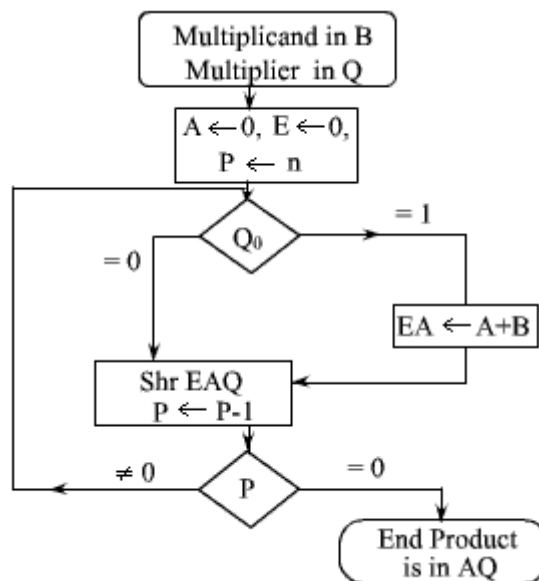

Figure 2.11: Flow chart of the multiplication operation

The working of multiplication algorithm is shown here with the help of an example.

Multiplicand B = 11001

	E	A	Q	P
Multiplier in Q	0	00000	10011	5
Q ₀ = 1, Add B		11001		

first partial product	0	11001		
Shr EAQ	0	01100	11001	4
Q ₀ = 1, Add B		11001		

Second partial product	1	00101		
Shr EAQ	0	10010	11100	3
Q ₀ = 0, Shr EAQ	0	01001	01110	2
Q ₀ = 0, Shr EAQ	0	01001	01110	1
Q ₀ = 1, Add B		11001		

fifth partial product	0	11101		
Shr EAQ	0	01110	11011	0
Stop				
Final products:	0	1110	11011	



Check your progress II

1. Multiplication of two numbers in binary representation can be performed by a process of

_____ and _____ operations.

2. Which of the following operation is extremely useful in serial transfer of data:
 - a. Logical microoperation
 - b. Arithmetic microoperation
 - c. Shift Microoperation
 - d. None of the above

4.5 Summary

1. An ALU is a digital circuit used to perform arithmetic and logic operations.
2. Examples of arithmetic operations are addition, subtraction, multiplication, and division. Examples of logic operations are comparisons of values such as NOT, AND, and OR.
3. The simplest type of operation is a NOT gate. This uses only a single transistor. It uses a single input and produces a single output, which is always the opposite of the input.
4. The OR gate results in a 1 if either the first or the second input is a 1. The OR gate only results in a 0 if both inputs are 0.
5. The AND gate results in a 1 only if both the first and second input are 1s.
6. The XOR gate, also pronounced X-OR gate, results in a 0 if both the inputs are 0 or if both are 1. Otherwise, the result is a 1.

4.6 Model Questions

1. Define ALU?
2. With block diagram show how a full adder can be designed by using two half adders and one OR gate.
3. With suitable block diagram explain Binary multiplier.

4. Demonstrate multiplication of two-binary numbers with the help of an example.
Design an arithmetic circuit to perform this multiplication.
5. What is an overflow in arithmetic operation of signed magnitude data? How is it detected?
6. Design an adder to add two 4-bit numbers.
7. How to multiply a number by 2 using shift operations, give an example.



Answers to Check your progress I

1. b
2. a
3. a
4. b
5. c



Answers to Check your progress II

1. SHIFT, ADD
2. b

MEMORY

5.0 Learning Objectives

After the completion of this unit, the learner shall be able to:

- Differentiate between various kinds of computer memory;
- Classify various types of computer memory according to memory hierarchy;
- Define cache memory;
- Differentiate between volatile and non-volatile memory;
- Classify various types of ROMs;
- Define Main Memory;
- Define word-addressable machine;
- Explain word-length in a computer;
- Define and classify different types of RAM;
- Explain binary storage cell;
- Differentiate between SRAM Versus DRAM;
- Define the Internal Organization of Memory Chips;

5.1 Concept of memory

We have already mentioned that digital computer works on stored programmed concept introduced by Von Neumann. We use memory to store the information, which includes both program and data. Due to several reasons, we have different kind of memories. We use different kind of memory at different level. The memory of computer is broadly categories into two categories:

- Internal, and
- External

Internal memory is used by CPU to perform task and external memory is used to store bulk information, which includes large software and data. Memory is used to store the information in digital form. The memory hierarchy is given by:

- Register
- Cache Memory
- Main Memory
- Magnetic Disk
- Removable media (Magnetic tape)

5.1.1 Register

This is a part of Central Processor Unit, so they reside inside the CPU. The information from main memory is brought to CPU and keep the information in register. Due to space and cost constraints, we have got a limited number of registers in a CPU. These are basically faster devices.

5.1.2 Cache Memory

Cache memory is a storage device placed in between CPU and main memory. These are semiconductor memories. These are basically fast memory device, faster than main memory. We can not have a big volume of cache memory due to its higher cost and some constraints of the CPU. Due to higher cost we can not replace the whole main memory by faster memory. Generally, the most recently used information is kept in the cache memory. It is brought from the main memory and placed in the cache memory. Now a days, we get CPU with internal cache.

5.1.3 Main Memory

Like cache memory, main memory is also semiconductor memory. But the main memory is relatively slower memory. We have to first bring the information (whether it is data or program), to main memory. CPU can work with the information available in main memory only.

5.1.4 Magnetic Disk

This is bulk storage device. We have to deal with huge amount of data in many applications. But we don't have so much semiconductor memory to keep this information in our computer. On the other hand, semiconductor memories are volatile in nature. It loses its content once we switch off the computer. For permanent storage, we use magnetic disk. The storage capacity of magnetic disk is very high.

5.1.5 Removable Media

For different application, we use different data. It may not be possible to keep all the information in magnetic disk. So, which ever data we are not using currently, can be kept in removable media. Magnetic tape is one kind of removable medium. CD is also a removable media, which is an optical device.

Register, cache memory and main memory are internal memory. Magnetic Disk, removable media are external memory. Internal memories are semiconductor memory. Semiconductor memories are categorized as volatile memory and non-volatile memory.

RAM: Random Access Memories are **volatile** in nature. As soon as the computer is switched off, the contents of memory are also lost.

ROM: Read only memories are **non volatile** in nature. The storage is permanent, but it is read only memory. We can not store new information in ROM.

Several types of ROM are available:

- **PROM:** Programmable Read Only Memory; it can be programmed once as per user requirements.
- **EPROM:** Erasable Programmable Read Only Memory; the contents of the memory can be erased and store new data into the memory. In this case, we have to erase whole information.
- **EEPROM:** Electrically Erasable Programmable Read Only Memory; in this type of memory the contents of a particular location can be changed without effecting the contents of other location.

5.1.6 Main Memory

The main memory of a computer is semiconductor memory. The main memory unit of computer is basically consisting of two kinds of memory:

- **RAM :** Random access memory; which is volatile in nature.
- **ROM :** Read only memory; which is non-volatile.

A byte addressable 32-bit computer, each memory word contains 4 bytes. A possible way of address assignment is shown in figure 3.1. The address of a word is always integer multiple of 4.

The main memory is usually designed to store and retrieve data in word length quantities. The word length of a computer is generally defined by the number of bits actually stored or retrieved in one main memory access.

Consider a machine with 32-bit address bus. If the word size is 32 bits, then the high order 30 bit will specify the address of a word. If we want to access any byte of the word, then it can be specified by the lower two bits of the address bus.

The data transfer between main memory and the CPU takes place through two CPU registers.

MAR : Memory Address Register

MDR : Memory Data Register.

If the MAR is k -bit long, then the total addressable memory location will be 2^k .

If the MDR is n -bit long, then the n bit of data is transferred in one memory cycle.

The transfer of data takes place through memory bus, which consist of address bus and data bus. In the above example, size of data bus is n -bit and size of address bus is k bit.

It also includes control lines like Read, Write and Memory Function Complete (MFC) for coordinating data transfer. In the case of byte addressable computer, another control line to be added to indicate the byte transfer instead of the whole word.

For memory operation, the CPU initiates a memory operation by loading the appropriate data i.e., address to MAR.

If it is a memory read operation, then it sets the read memory control line to 1. Then the contents of the memory location are brought to MDR and the memory control circuitry indicates this to the CPU by setting MFC to 1.

If the operation is a memory write operation, then the CPU places the data into MDR and sets the write memory control line to 1. Once the contents of MDR are stored in specified memory location, then the memory control circuitry indicates the end of operation by setting MFC to 1.

A useful measure of the speed of memory unit is the time that elapses between the initiation of an operation and the completion of the operation (for example, the time between Read and MFC). This is referred to as Memory Access Time. Another measure is memory cycle time. This is the minimum time delay between the initiation two independent memory operations (for example, two successive memory read operation). Memory cycle time is slightly larger than memory access time.



Check your progress I

1. _____ memory is a storage device placed in between CPU and main memory.
2. _____ memories are volatile in nature.
3. _____ can be programmed once as per user requirements.
4. The smallest unit of information is known as_____.

5.2 Binary Storage Cell

The binary storage cell is the basic building block of a memory unit. The binary storage cell that stores one bit of information can be modelled by an SR latch with associated gates. This model of binary storage cell is shown in the figure 3.2.

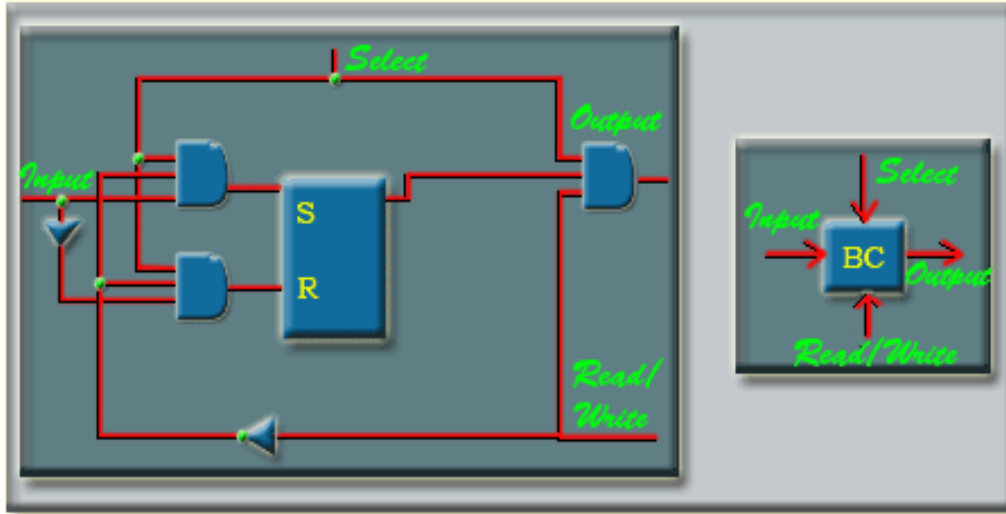

Figure 3.2: Binary Storage cell made up of SR-Latch

5.2.1 One-bit Binary Cell (BC)

The binary cell stores one bit of information in its internal latch. Control input to binary cell.

Select	Read/Write	Memory Operation
0	X	None
1	0	Write
1	1	Read

The storage part is modelled here with SR-latch, but in reality, it is an electronics circuit made up of transistors. The memory constructed with the help of transistors is known as semiconductor memory. The semiconductor memories are termed as Random Access Memory(RAM), because it is possible to access any memory location in random. Depending on the technology used to construct a RAM, there are two types of RAM:

SRAM: Static Random Access Memory.

DRAM: Dynamic Random Access Memory.

5.2.1.1 Dynamic Ram (DRAM)

A DRAM is made with cells that store data as charge on capacitors. The presence or absence of charge in a capacitor is interpreted as binary 1 or 0. Because capacitors have a natural tendency to discharge due to leakage current, dynamic RAM require periodic charge refreshing to maintain data storage. The term dynamic refers to this tendency of the stored charge to leak away, even with power continuously applied. A typical DRAM structure for an individual cell that stores one-bit information is shown in the figure 3.3.



Figure 3.3: Dynamic RAM (DRAM) cell

For the write operation, a voltage signal is applied to the bit line B, a high voltage represents 1 and a low voltage represents 0. A signal is then applied to the address line, which will turn on the transistor T, allowing a charge to be transferred to the capacitor.

For the read operation, when a signal is applied to the address line, the transistor T turns on and the charge stored on the capacitor is fed out onto the bit line B and to a sense amplifier.

The sense amplifier compares the capacitor voltage to a reference value and determines if the cell contains a logic 1 or a logic 0.

The read out from the cell discharges the capacitor, which must be restored to complete the read operation.

Due to the discharge of the capacitor during read operation, the read operation of DRAM is termed as destructive read out.

5.2.2.2 Static RAM (SRAM)

In an SRAM, binary values are stored using traditional flip-flop constructed with the help of transistors. A static RAM will hold its data as long as power is supplied to it. A typical SRAM constructed with transistors is shown in the figure 3.4.

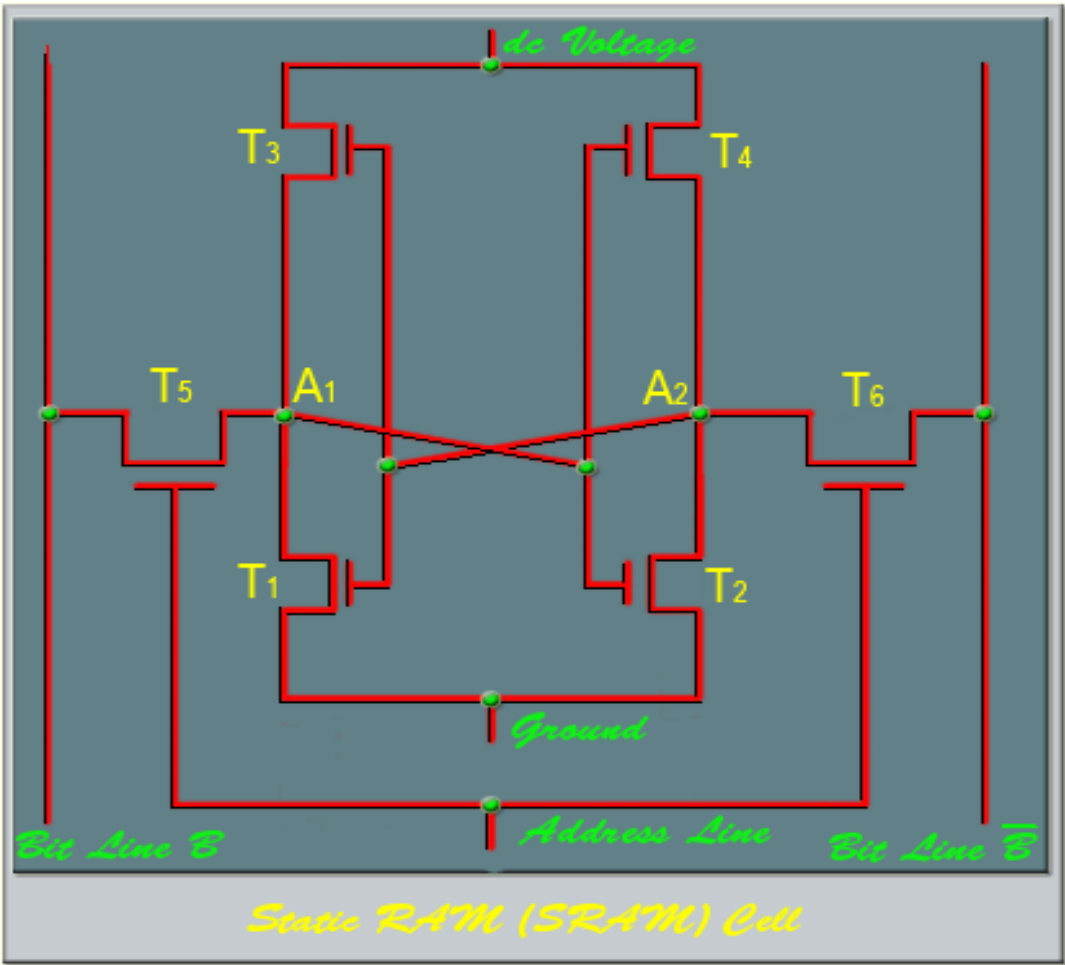

Figure 3.4: Static RAM (SRAM) cell

Four transistors (T_1, T_2, T_3, T_4) are cross connected in an arrangement that produces a stable logic state. In logic state 1, point A_1 is high and point A_2 is low; in this state T_1 and T_4 are off, and T_2 and T_3 are on.

In logic state 0, point A_1 is low and point A_2 is high; in this state T_1 and T_4 are on, and T_2 and T_3 are off.

Both states are stable as long as the dc supply voltage is applied. The address line is used to open or close a switch which is nothing but another transistor. The address line controls two transistors (T_5 and T_6).

When a signal is applied to this line, the two transistors are switched on, allowing a read or write operation.

For a write operation, the desired bit value is applied to line B, and its complement is applied to line \bar{B} . This forces the four transistors (T_1, T_2, T_3, T_4) into the proper state.

For a read operation, the bit value is read from the line B. When a signal is applied to the address line, the signal of point A_1 is available in the bit line B.

5.2.2.3 SRAM Versus DRAM

- Both static and dynamic RAMs are volatile, that is, it will retain the information as long as power supply is applied.
- A dynamic memory cell is simpler and smaller than a static memory cell. Thus a DRAM is more dense, i.e., packing density is high (more cell per unit area). DRAM is less expensive than corresponding SRAM.
- DRAM requires the supporting refresh circuitry. For larger memories, the fixed cost of the refresh circuitry is more than compensated for by the less cost of DRAM cells
- SRAM cells are generally faster than the DRAM cells. Therefore, to construct faster memory modules (like cache memory) SRAM is used.

5.3 Internal Organization of Memory Chips

A memory cell is capable of storing 1-bit of information. A number of memory cells are organized in the form of a matrix to form the memory chip. One such organization is shown in the Figure 3.5.

Each row of cells constitutes a memory word, and all cell of a row are connected to a common line which is referred as word line. An address decoder is used to drive the word line. At a particular instant, one-word line is enabled depending on the address present in the address bus. The cells in each column are connected by two lines. These are known as bit lines. These bit lines are connected to data input line and data output line through a Sense/Write circuit. During a Read operation, the Sense/Write circuit sense, or read the information stored in the cells selected by a word line and transmit this information to the output data line. During a write operation, the sense/write circuit receive information and store it in the cells of the selected word.

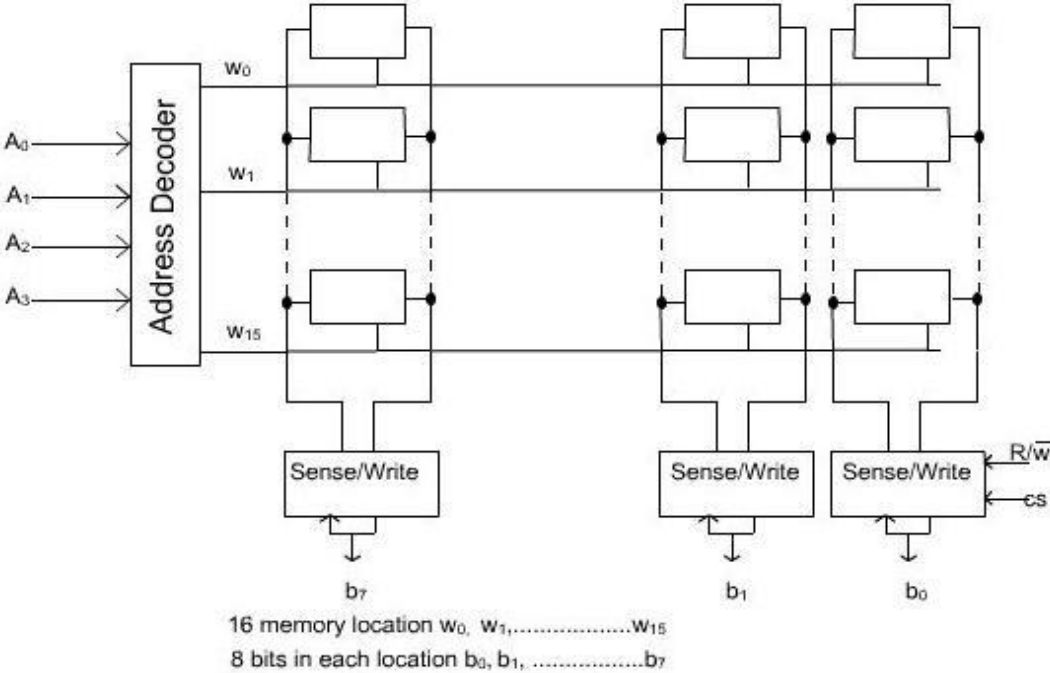

Figure 3.5: 16 X 8 Memory Organization

A memory chip consisting of 16 words of 8 bits each, usually referred to as 16 x 8 organization. The data input and data output line of each Sense/Write circuit are connected to a single bidirectional data line in order to reduce the pin required. For 16 words, we need an address bus of size 4. In addition to address and data lines, two control lines, R/\bar{W} and CS, are provided. The R/\bar{W} line is to used to specify the required operation about read or write. The CS (Chip Select) line is required to select a given chip in a multi chip memory system.

Consider a slightly larger memory unit that has 1K (1024) memory cells.

128 x 8 memory chips:

If it is organized as a 128 x 8 memory chips, then it has got 128 memory words of size 8 bits. So, the size of data bus is 8 bits and the size of address bus is 7 bits ($2^7 = 128$). The storage organization of 128 x 8 memory chip is shown in the figure 3.6.

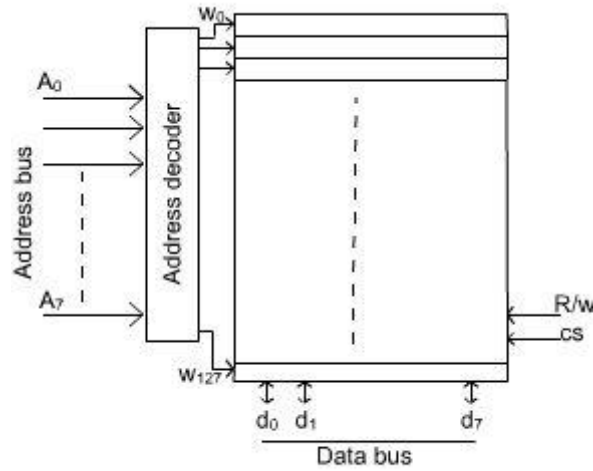

Figure 3.6: 128 x 8 Memory Chip

1024 x 1 memory chips:

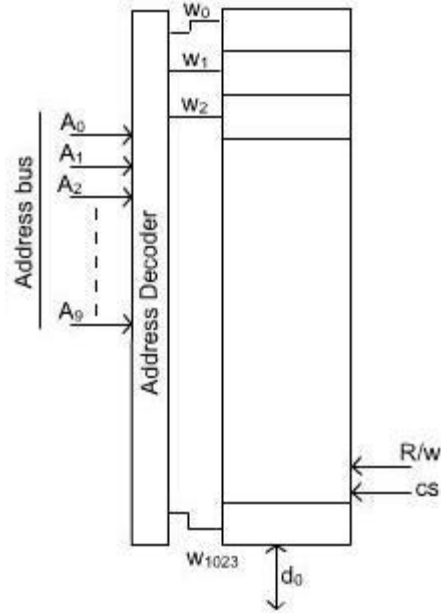

Figure 3.7: 1024 x 1 Memory chip

If it is organized as a 1024 x 1 memory chips, then it has got 1024 memory words of size 1 bit only. Therefore, the size of data bus is 1 bit and the size of address bus is 10 bits ($2^{10} = 1024$ bits).

A particular memory location is identified by the contents of memory address bus. A decoder is used to decode the memory address. There are two ways of decoding of a memory address depending upon the organization of the memory module. In one case, each memory word is organized in a row. In this case whole memory address bus is used together to decode the address of the specified location. The memory organization of 1024 x 1 memory chip is shown in the figure 3.7. In second case, several memory words are organized in one row. In this case, address bus is divided into two groups. One group is used to form the row address and the second group is used to form the column address. Consider the memory organization of 1024 x 1 memory chip. The required 10-bit address is divided into two groups of 5 bits each to form the row and column address of the cell array. A row address selects a row of 32 cells, all of which are accessed in parallel. However, according to the column address, only one of these cells is connected to the external data line via the input output multiplexers. The arrangement for row address and column address decoders is shown in the figure 3.8.

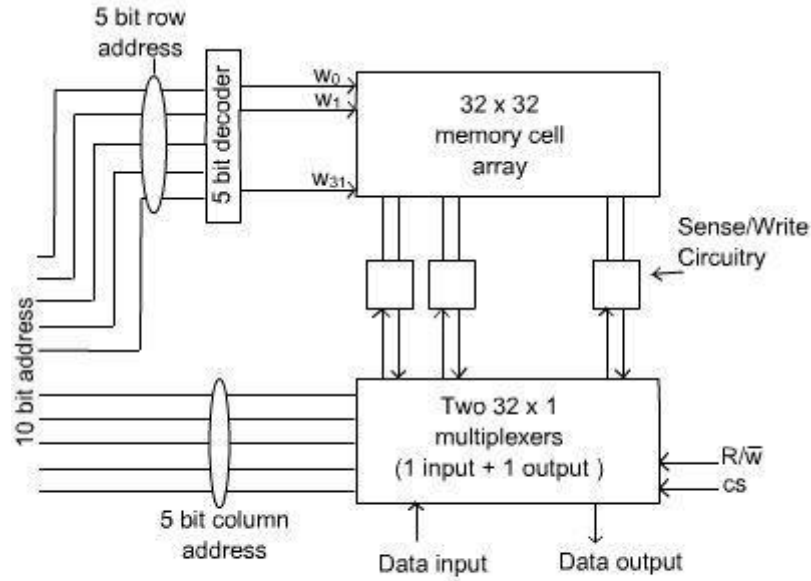

Figure 3.8: Organizaion of 1k x 1 Memory chip

The commercially available memory chips contain a much larger number of cells. As for example, a memory unit of 1MB (mega byte) size, organized as 1M x 8, contains memory cells. It has got 220 memory location and each memory location contains 8 bits information. The size of address bus is 20 and the size of data bus is 8.

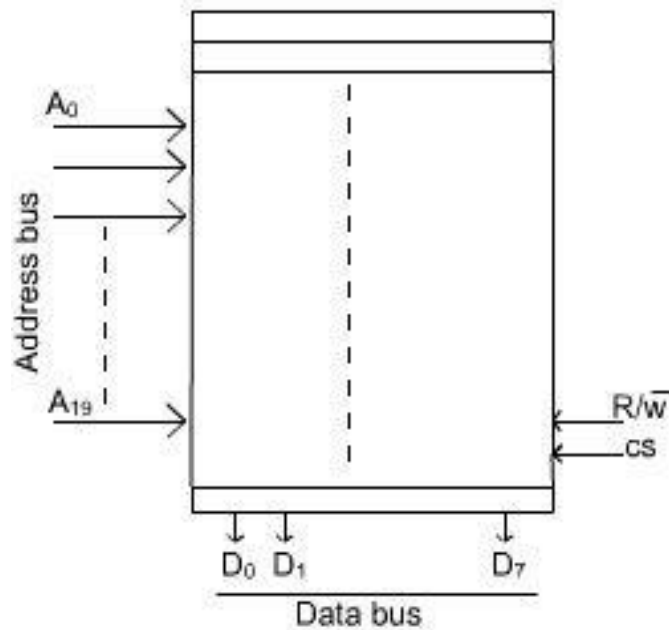

Figure 3.9: 1 MB(Mega Byte) Memory Chip

The number of pins of a memory chip depends on the data bus and address bus of the memory module. To reduce the number of pins required for the chip, we use another scheme for address decoding. The cells are organized in the form of a square array. The address bus is divided into two groups, one for column address and other one is for row address. In this case, high- and low-order 10 bits of 20-bit address constitute of row and column address of a given cell, respectively. In order to reduce the number of pin needed for external connections, the row and column addresses are multiplexed on ten pins. During a Read or a Write operation, the row address is applied first. In response to a signal pulse on the Row Address Strobe (RAS) input of the chip, this part of the address is loaded into the row address latch.

All cell of this particular row is selected. Shortly after the row address is latched, the column address is applied to the address pins. It is loaded into the column address latch with the help of Column Address Strobe (CAS) signal, similar to RAS. The information in this latch is decoded and the appropriate Sense/Write circuit is selected.

For a Write operation, the information at the input lines are transferred to the selected circuits.

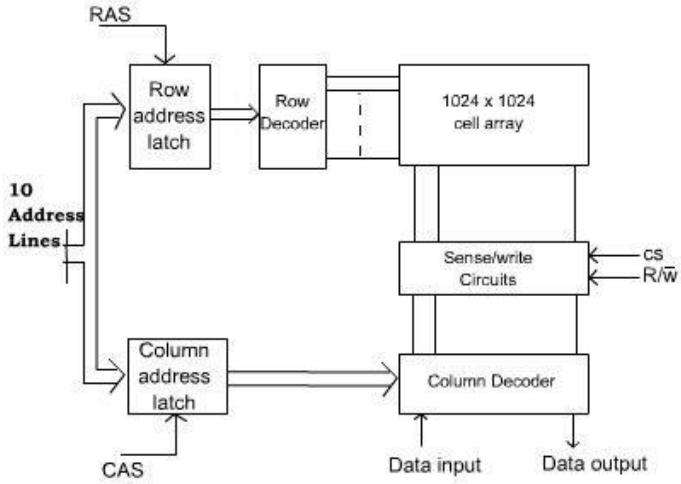

Figure 3.10: Organization of a 1M x 1 Memory chip.

The 1MB (Megabyte) memory chip with 20 address lines as shown in the figure 3.9. The same memory chip (1MB) with 10 address lines (where row & column address are multiplexed) is shown in Figure 3.10.

Now we discuss the design of memory subsystem using memory chips. Consider a memory chips of capacity 16K x 8. The requirement is to design a memory subsystem of capacity 64K x 16. Each memory chip has got eight lines for data bus, but the data bus size of memory subsystem is 16 bits.

The total requirement is for 64K memory location, so four such units are required to get the 64K memory location. For 64K memory location, the size of address bus is 16. On the other hand, for 16K memory location, size of address bus is 14 bits.

Each chip has a control input line called Chip Select (CS). A chip can be enabled to accept data input or to place the data on the output bus by setting its Chip Select input to 1. The address bus for the 64K memory is 16 bits wide. The high order two bits of the address are

decoded to obtain the four chip-select control signals. The remaining 14 address bits are connected to the address lines of all the chips. They are used to access a specific location inside each chip of the selected row. The R/\overline{W} inputs of all chips are tied together to provide a common $READ/\overline{WRITE}$ control.

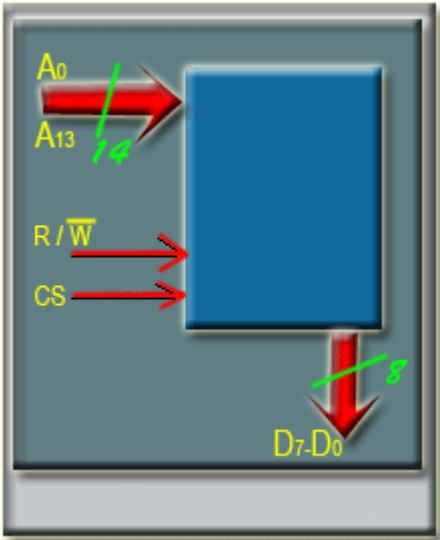

Figure 3.11: 16k x 8 Memory chip

The block diagram of a 16K x 8 memory chip is shown in the figure 3.11. The block diagram of a 64k x 16 memory module constructed with the help of eight 16k x 8 memory chips is shown in the figure 3.12.

5. Magnetic disk is a bulk storage device.
6. Semiconductor memories are volatile in nature.
7. The storage capacity of magnetic disk is very high.
8. Magnetic tape is one kind of removable medium.
9. Semiconductor memories are categorized as volatile memory and non-volatile memory.
10. Programmable Read Only Memory can be programmed once as per user requirements.
11. In Erasable Programmable Read Only Memory, the contents of the memory can be erased and store new data into the memory.
12. In Electrically Erasable Programmable Read Only Memory, the contents of a particular location can be changed without effecting the contents of other location.
13. The permanent information is kept in ROM and the user space is basically in RAM.
14. The smallest unit of information is known as bit (binary digit).
15. In one memory cell we can store one bit of information.
16. 8 bits together is termed as a byte.
17. The maximum size of main memory that can be used in any computer is determined by the addressing scheme.
18. The address of a word is always integer multiple of 4.
19. The word length of a computer is generally defined by the number of bits actually stored or retrieved in one main memory access.
20. The binary storage cell is the basic building block of a memory unit.
21. The binary storage cell that stores one bit of information can be modelled by an SR latch with associated gates.
22. A memory cell is capable of storing 1-bit of information.
23. A number of memory cells are organized in the form of a matrix to form the memory chip.
24. Each row of cells constitutes a memory word, and all cell of a row are connected to a common line which is referred as word line.

5.5 Model Questions

1. Define memory hierarchy?
2. Define cache memory. Why it is used?
3. Why removable media is used?
4. What are the various types of ROMs? Explain.
5. What is Main Memory? How it can be classified?
6. What is word addressable machines?
7. Define word length in a computer.
8. What is Random Access memory? Define different types of RAM.
9. What is a binary storage cell? Explain.
10. Explain the working of SRAM. Explain the working of DRAM.
11. Explain the difference between SRAM Versus DRAM.
12. Define the Internal Organization of Memory Chips.
13. What is word line?
14. Explain 16 X 8 memory organization.



Answers to Check your progress I

1. Cache
2. Semiconductor
3. Programmable Read Only Memory
4. bit



Answers to Check your progress II

1. 4
2. 1-bit
3. binary storage cell
4. 8

CACHE MEMORY

6.0 Learning Objectives

After the completion of this unit, the learner shall be able to:

- Define the principle of locality;
- Explain the working principle of Cache memory;
- Demonstrate the working principle of replacement algorithms;
- Know the working of the mapping function;
- Differentiate between various types of mapping techniques;

6.1 Cache Memory

Analysis of large number of programs has shown that a number of instructions are executed repeatedly. This may be in the form of a simple loops, nested loops, or a few procedures that repeatedly call each other. It is observed that many instructions in each of a few localized areas of the program are repeatedly executed, while the remainder of the program is accessed relatively less. This phenomenon is referred to as locality of reference.

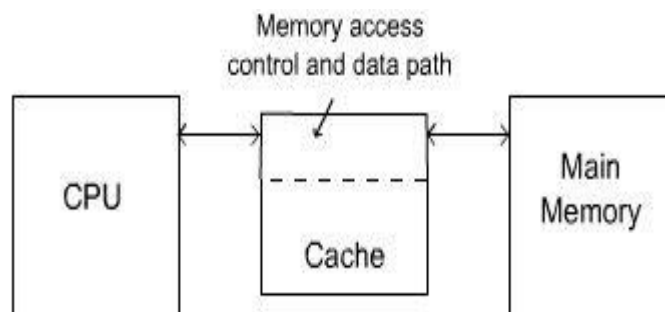

Figure 3.13: Cache memory between CPU and the main memory

Now, if it can be arranged to have the active segments of a program in a fast memory, then the total execution time can be significantly reduced. It is the fact that CPU is a faster device and memory is a relatively slower device. Memory access is the main bottleneck for

the performance efficiency. If a faster memory device can be inserted between main memory and CPU, the efficiency can be increased. The faster memory that is inserted between CPU and Main Memory is termed as Cache memory. To make this arrangement effective, the cache must be considerably faster than the main memory, and typically it is 5 to 10 time faster than the main memory. This approach is more economical than the use of fast memory device to implement the entire main memory. This is also a feasible due to the locality of reference that is present in most of the program, which reduces the frequent data transfer between main memory and cache memory. The inclusion of cache memory between CPU and main memory is shown in Figure 3.13.

6.2 Operation of Cache Memory

The memory control circuitry is designed to take advantage of the property of locality of reference. Some assumptions are made while designing the memory control circuitry:

- The CPU does not need to know explicitly about the existence of the cache.
- The CPU simply makes Read and Write request. The nature of these two operations are same whether cache is present or not.
- The address generated by the CPU always refer to location of main memory.
- The memory access control circuitry determines whether or not the requested word currently exists in the cache.

When a Read request is received from the CPU, the contents of a block of memory words containing the location specified are transferred into the cache. When any of the locations in this block is referenced by the program, its contents are read directly from the cache.

Consider the case where the addressed word is not in the cache and the operation is a read. First the block of words is brought to the cache and then the requested word is forwarded to the CPU. But it can be forwarded to the CPU as soon as it is available to the cache, instead of the whole block to be loaded in the cache. This is called load through, and there is some scope to save time while using load through policy.

The cache memory can store a number of such blocks at any given time. The correspondence between the Main Memory Blocks and those in the cache is specified by means of a mapping function.

When the cache is full and a memory word is referenced that is not in the cache, a decision must be made as to which block should be removed from the cache to create space to bring the new block to the cache that contains the referenced word. Replacement algorithms are used to make the proper selection of block that must be replaced by the new one.

When a write request is received from the CPU, there are two ways that the system can proceed. In the first case, the cache location and the main memory location are updated simultaneously. This is called the store through method or write through method.

The alternative is to update the cache location only. During replacement time, the cache block will be written back to the main memory. This method is called write back method. If there is no new write operation in the cache block, it is not required to write back the cache block in the main memory. This information can be kept with the help of an associated bit. This bit is set while there is a write operation in the cache block. During replacement, it checks this bit, if it is set, then write back the cache block in main memory otherwise not. This bit is known as dirty bit. If the bit gets dirty (set to one), writing to main memory is required.

The write through method is simpler, but it results in unnecessary write operations in the main memory when a given cache word is updated a number of times during its cache residency period.

During a write operation, if the address word is not in the cache, the information is written directly into the main memory. A write operation normally refers to the location of data areas and the property of locality of reference is not as pronounced in accessing data when write operation is involved. Therefore, it is not advantageous to bring the data block to the cache when there a write operation, and the addressed word is not present in cache.

6.3 Mapping Functions

The mapping functions are used to map a particular block of main memory to a particular block of cache. This mapping function is used to transfer the block from main memory to cache memory. Three different mapping functions are available:

- Direct mapping: A particular block of main memory can be brought to a particular block of cache memory. So, it is not flexible.
- Associative mapping: In this mapping function, any block of Main memory can potentially reside in any cache block position. This is much more flexible mapping method.
- Block-set-associative mapping: In this method, blocks of cache are grouped into sets, and the mapping allows a block of main memory to reside in any block of a specific set. From the flexibility point of view, it is in between to the other two methods.

All these three mapping methods are explained with the help of an example.

Consider a cache of 4096 (4K) words with a block size of 32 words. Therefore, the cache is organized as 128 blocks. For 4K words, required address lines are 12 bits. To select one of the blocks out of 128 blocks, we need 7 bits of address lines and to select one word out of 32 words, we need 5 bits of address lines. So the total 12 bits of address is divided for two groups, lower 5 bits are used to select a word within a block, and higher 7 bits of address are used to select any block of cache memory.

Let us consider a main memory system consisting 64K words. The size of address bus is 16 bits. Since the block size of cache is 32 words, so the main memory is also organized as block size of 32 words. Therefore, the total number of blocks in main memory is 2048 (2K x 32 words = 64K words). To identify any one block of 2K blocks, we need 11 address lines. Out of 16 address lines of main memory, lower 5 bits are used to select a word within a block and higher 11 bits are used to select a block out of 2048 blocks.

Number of blocks in cache memory is 128 and number of blocks in main memory is 2048, so at any instant of time only 128 blocks out of 2048 blocks can reside in cache memory. Therefore, we need mapping function to put a particular block of main memory into appropriate block of cache memory.

6.3.1 Direct Mapping Technique

The simplest way of associating main memory blocks with cache block is the direct mapping technique. In this technique, block k of main memory maps into block k modulo m of the cache, where m is the total number of blocks in cache. In this example, the value of m is 128. In direct mapping technique, one particular block of main memory can be transferred to a particular block of cache which is derived by the modulo function.

Since more than one main memory block is mapped onto a given cache block position, contention may arise for that position. This situation may occur even when the cache is not full. Contention is resolved by allowing the new block to overwrite the currently resident block. So, the replacement algorithm is trivial.

The detail operation of direct mapping technique is as follows:

The main memory address is divided into three fields. The field size depends on the memory capacity and the block size of cache. In this example, the lower 5 bits of address is used to identify a word within a block. Next 7 bits are used to select a block out of 128 blocks (which is the capacity of the cache). The remaining 4 bits are used as a TAG to identify the proper block of main memory that is mapped to cache.

When a new block is first brought into the cache, the high order 4 bits of the main memory address are stored in four TAG bits associated with its location in the cache. When the CPU generates a memory request, the 7-bit block address determines the corresponding cache block. The TAG field of that block is compared to the TAG field of the address. If they match, the desired word specified by the low-order 5 bits of the address is in that block of the cache.

If there is no match, the required word must be accessed from the main memory, that is, the contents of that block of the cache is replaced by the new block that is specified by the new address generated by the CPU and correspondingly the TAG bit will also be changed by the high order 4 bits of the address. The whole arrangement for direct mapping technique is shown in the figure 3.14.

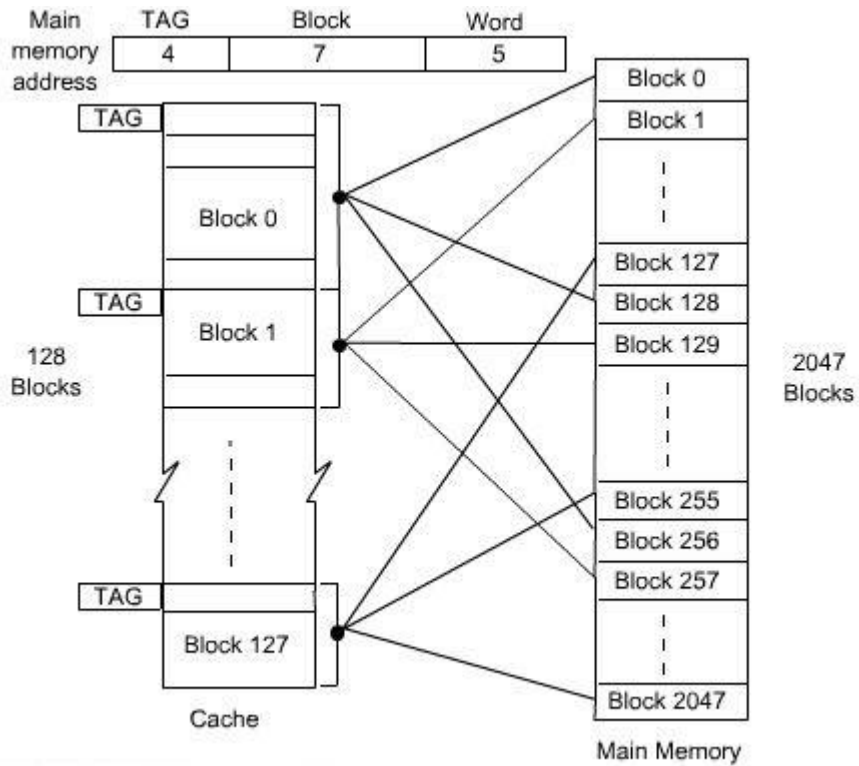

Figure 3.14: Direct-mapping cache

6.3.2 Associated Mapping Technique

In the associative mapping technique, a main memory block can potentially reside in any cache block position. In this case, the main memory address is divided into two groups, low-order bits identify the location of a word within a block and high-order bits identifies the block. In the example here, 11 bits are required to identify a main memory block when it is resident in the cache, high-order 11 bits are used as TAG bits and low-order 5 bits are used to identify a word within a block. The TAG bits of an address received from the CPU must be compared to the TAG bits of each block of the cache to see if the desired block is present.

In the associative mapping, any block of main memory can go to any block of cache, so it has got the complete flexibility and we have to use proper replacement policy to replace a block from cache if the currently accessed block of main memory is not present in cache. It might not be practical to use this complete flexibility of associative mapping technique due to searching overhead, because the TAG field of main memory address has to be compared

with the TAG field of all the cache block. In this example, there are 128 blocks in cache and the size of TAG is 11 bits. The whole arrangement of Associative Mapping Technique is shown in the figure 3.15.

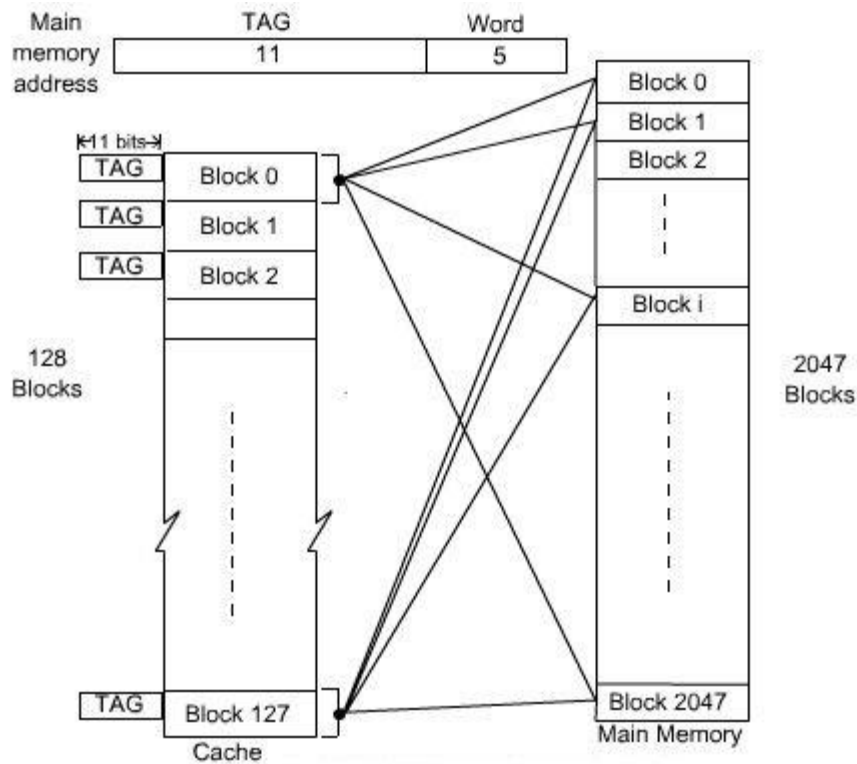

Figure 3.15: Associated Mapping Cache

6.3.3 Block-Set-Associative Mapping Technique

This mapping technique is intermediate to the previous two techniques. Blocks of the cache are grouped into sets, and the mapping allows a block of main memory to reside in any block of a specific set. Therefore, the flexibility of associative mapping is reduced from full freedom to a set of specific blocks. This also reduces the searching overhead, because the search is restricted to number of sets, instead of number of blocks. Also, the contention problem of the direct mapping is eased by having a few choices for block replacement. Consider the same cache memory and main memory organization of the previous example. Organize the cache with 4 blocks in each set. The TAG field of associative mapping technique is divided into two groups, one is termed as SET bit and the

second one is termed as TAG bit. Each set contains 4 blocks, total number of set is 32. The main memory address is grouped into three parts: low-order 5 bits are used to identifies a word within a block. Since there are total 32 sets present, next 5 bits are used to identify the set. High-order 6 bits are used as TAG bits.

The 5-bit set field of the address determines which set of the cache might contain the desired block. This is similar to direct mapping technique, in case of direct mapping, it looks for block, but in case of block-set-associative mapping, it looks for set. The TAG field of the address must then be compared with the TAGs of the four blocks of that set. If a match occurs, then the block is present in the cache; otherwise the block containing the addressed word must be brought to the cache. This block will potentially come to the corresponding set only. Since, there are four blocks in the set, we have to choose appropriately which block to be replaced if all the blocks are occupied. Since the search is restricted to four blocks only, so the searching complexity is reduced. The whole arrangement of block-set-associative mapping technique is shown in the figure 3.15.

It is clear that if we increase the number of blocks per set, then the number of bits in SET field is reduced. Due to the increase of blocks per set, complexity of search is also increased. The extreme condition of 128 blocks per set requires no set bits and corresponds to the fully associative mapping technique with 11 TAG bits. The other extreme of one block per set is the direct mapping method.

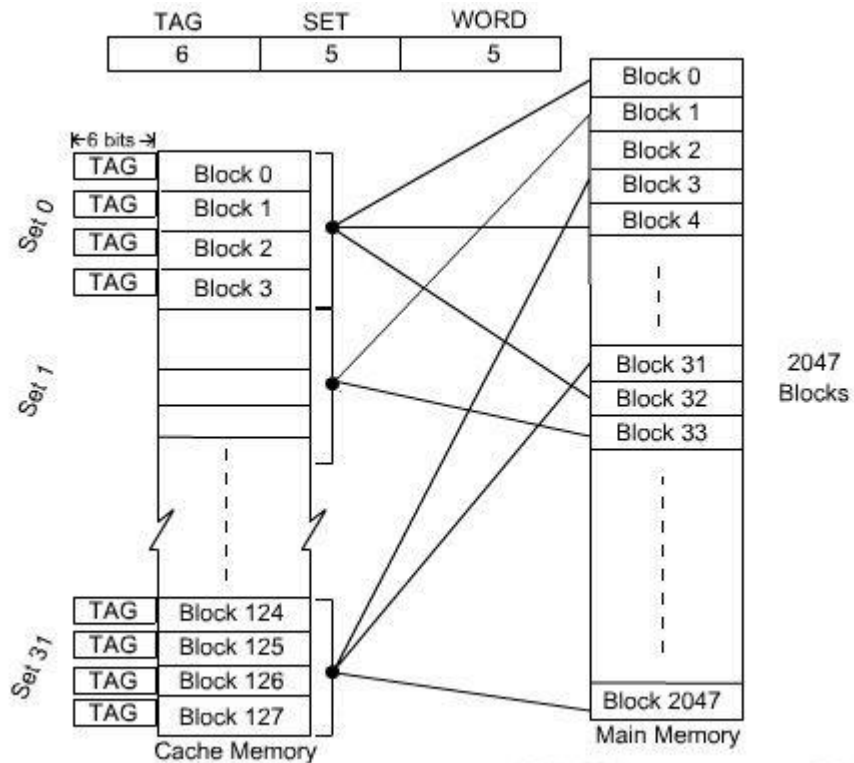

Figure 3.15: Block-set Associated mapping Cache with 4 blocks/set



Check your progress I

1. The faster memory that is inserted between CPU and Main Memory is termed as _____ memory.
2. The correspondence between the Main Memory Blocks and those in the cache is specified by means of a _____.
3. In a _____ mapped cache, each memory address has only one possible location in the cache where its data might be found; that is, each memory address maps directly to a cache location.
4. In a _____ cache, an address can be cached in any line of the cache.
5. The _____ cache is a compromise between a direct-mapped cache and a fully associative cache.

6.4 Replacement Algorithms

When a new block must be brought into the cache and all the positions that it may occupy are full, a decision must be made as to which of the old blocks is to be overwritten. In general, a policy is required to keep the block in cache when they are likely to be referenced in near future. However, it is not easy to determine directly which of the block in the cache are about to be referenced. The property of locality of reference gives some clue to design good replacement policy.

6.4.1 Least Recently Used (LRU) Replacement policy

Since program usually stay in localized areas for reasonable periods of time, it can be assumed that there is a high probability that blocks which have been referenced recently will also be referenced in the near future. Therefore, when a block is to be overwritten, it is a good decision to overwrite the one that has gone for longest time without being referenced. This is defined as the least recently used (LRU) block. Keeping track of LRU block must be done as computation proceeds.

Consider a specific example of a four-block set. It is required to track the LRU block of this four-block set. A 2-bit counter may be used for each block.

When a hit occurs, that is, when a read request is received for a word that is in the cache, the counter of the block that is referenced is set to 0. All counters which values originally lower than the referenced one are incremented by 1 and all other counters remain unchanged.

When a miss occurs, that is, when a read request is received for a word and the word is not present in the cache, we have to bring the block to cache.

There are two possibilities in case of a miss: If the set is not full, the counter associated with the new block loaded from the main memory is set to 0, and the values of all other counters are incremented by 1.

If the set is full and a miss occurs, the block with the counter value 3 is removed, and the new block is put in its place. The counter value is set to zero. The other three block counters are incremented by 1.

It is easy to verify that the counter values of occupied blocks are always distinct. Also, it is trivial that highest counter value indicates least recently used block.

6.4.2 First In First Out (FIFO) replacement policy

A reasonable rule may be to remove the oldest from a full set when a new block must be brought in. While using this technique, no updating is required when a hit occurs. When a miss occurs and the set is not full, the new block is put into an empty block and the counter values of the occupied block will be increment by one. When a miss occurs and the set is full, the block with highest counter value is replaced by new block and counter is set to 0, counter value of all other blocks of that set is incremented by 1. The overhead of the policy is less, since no updation is required during hit.

6.4.3 Random replacement policy

The simplest algorithm is to choose the block to be overwritten at random. Interestingly enough, this simple algorithm has been found to be very effective in practice.

6.5 Summary

1. Cache is very fast and small memory that is placed in between the CPU and the main memory.
2. Cache memory is used to reduce the average memory access time.
3. There are three basic categories of caches: direct mapped, set associative, and fully associative.
4. In a direct-mapped cache, each memory address maps to only one possible location in the cache where that address's data might appear.
5. During replacement time, the cache block will be written back to the main memory. This method is called write back method.
6. In Direct mapping, a particular block of main memory can be brought to a particular block of cache memory. So, it is not flexible.
7. In Associative mapping function, any block of Main memory can potentially reside in any cache block position. This is much more flexible mapping method.
8. In Block-set-associative mapping method, blocks of cache are grouped into sets, and the mapping allows a block of main memory to reside in any block of a specific set. From the flexibility point of view, it is in between to the other two methods.

6.6 Model Questions

1. What is principle of locality? Explain.
2. What is Cache memory? Explain the operation of cache memory.
3. What are replacement algorithms? What are the two strategies for handling write requests by the cache memory?
4. What is the difference between write back and write through method?

5. What is a mapping function? Explain various types of mapping function for cache memory.
6. Explain the functioning of Direct Mapping Technique.
7. Explain the functioning of Associative mapping Technique.
8. Explain the functioning of Block-set-associative mapping Technique.
9. Explain Least Recently Used (LRU) Replacement policy?



Answers to Check your progress I

1. Cache
2. mapping function
3. direct
4. fully associative
5. set-associative

MEMORY MANAGEMENT

7.0 Learning Objectives

After the completion of this unit, the learner shall be able to:

- Know the importance of memory management;
- define state;
- define five state of a process;
- Know the various reasons for the suspension of a process;
- Explain swapping and partitioning of the memory space;
- Differentiate between fixed size partitions and variable size partitions;

7.1 Main Memory

The main working principle of digital computer is Von-Neumann stored program principle. First of all, we have to keep all the information in some storage, mainly known as main memory, and CPU interacts with the main memory only. Therefore, memory management is an important issue while designing a computer system. On the otherhand, everything cannot be implemented in hardware, otherwise the cost of system will be very high. Therefore, some of the tasks are performed by software program. Collection of such software programs are basically known as operating systems. So, operating system is viewed as extended machine. Many more functions or instructions are implemented through software routine. The operating system is mainly memory resistant, i.e., the operating system is loaded into main memory.

Due to that, the main memory of a computer is divided into two parts. One part is reserved for operating system. The other part is for user program. The program currently being executed by the CPU is loaded into the user part of the memory. The two parts of the main memory are shown in the figure 3.17. In a uni-programming system, the program currently being executed is loaded into the user part of the memory.

In a multiprogramming system, the user part of memory is subdivided to accommodate multiple process. The task of subdivision is carried out dynamically by operating system and is known as memory management.

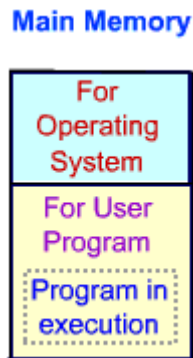

Figure 3.17: Partition of main memory.

Efficient memory management is vital in a multiprogramming system. If only a few processes are in memory, then for much of the time all of the process will be waiting for I/O and the processor will idle. Thus, memory needs to be allocated efficiently to pack as many processes into main memory as possible.

When memory holds multiple processes, then the process can move from one process to another process when one process is waiting. But the processor is so much faster, then I/O that it will be common for all the processes in memory to be waiting for I/O. Thus, even with multiprogramming, a processor could be idle most of the time.

Due to the speed mismatch of the processor and I/O device, the status at any point in time is referred to as a state.

There are five defined state of a process as shown in the figure 3.18. When a process starts to execute, it is placed in the process queue and it is in the new state. As resources become available, then the process is placed in the ready queue. At any given time, a process may be in one of the following five states.

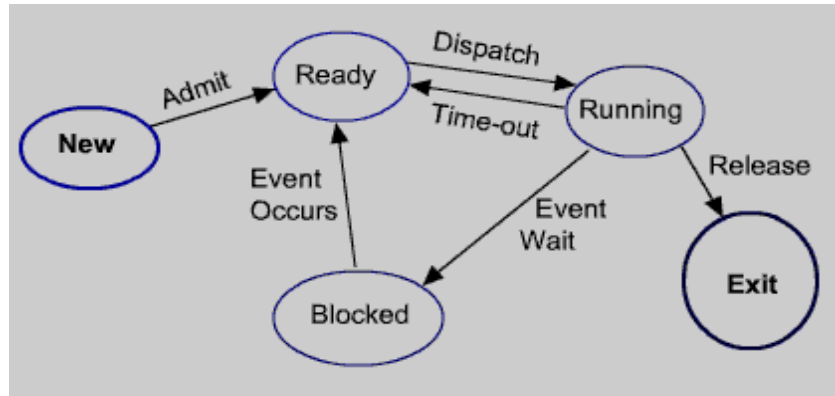

Figure 3.18: Five State process model

1. **New** :A program is admitted to execute, but not yet ready to execute. The operating system will initialize the process by moving it to the ready state.
2. **Ready** :The process is ready to execute and is waiting access to the processor.
3. **Running** :The process is being executed by the processor. At any given time, only one process is in running state.
4. **Waiting**:The process is suspended from execution, waiting for some system resource, such as I/O.
5. **Exit** :The process has terminated and will be destroyed by the operating system.

The processor alternates between executing operating system instructions and executing user processes. While the operating system is in control, it decides which process in the queue should be executed next.

A process being executed may be suspended for a variety of reasons. If it is suspended because the process requests I/O, then it is placed in the appropriate I/O queue. If it is suspended because of a timeout or because the operating system must attend to processing some of its task, then it is placed in ready state.

We know that the information of all the process that are in execution must be placed in main memory. Since there is fix amount of memory, so memory management is an important issue

7.2 Memory Management

In an uniprogramming system, main memory is divided into two parts: one part for the operating system and the other part for the program currently being executed. In multiprogramming system, the user part of memory is subdivided to accommodate multiple processes.

The task of subdivision is carried out dynamically by the operating system and is known as memory management. In uniprogramming system, only one program is in execution. After completion of one program, another program may start. In general, most of the programs involve I/O operation. It must take input from some input device and place the result in some output device. Partition of main memory for uni-program and multi program is shown in figure 3.19.

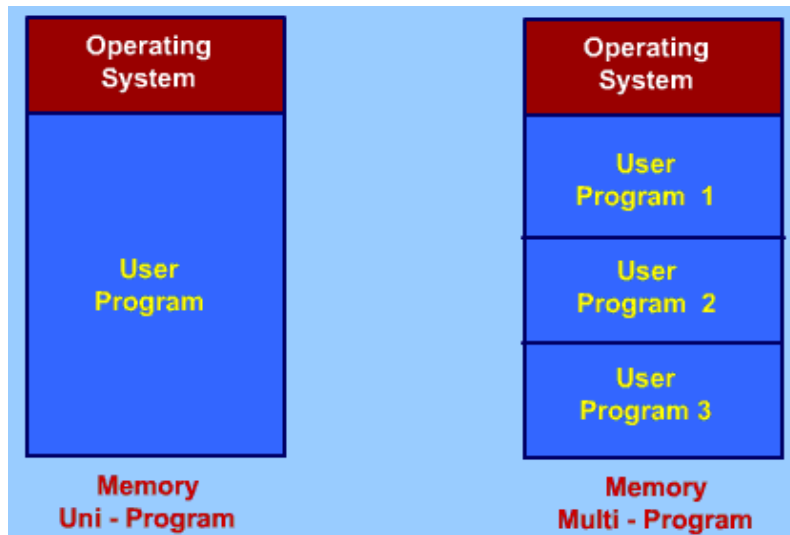

Figure 3.19: Partition of Main Memory

To utilize the idle time of CPU, we are shifting the paradigm from uniprogram environment to multiprogram environment.

Since the size of main memory is fixed, it is possible to accommodate only few processes in the main memory. If all are waiting for I/O operation, then again CPU remains idle. To utilize the idle time of CPU, some of the process must be off loaded from the memory and new process must be brought to this memory place. This is known swapping.

7.2.1 What is swapping?

1. The process waiting for some I/O to complete, must stored back in disk.
2. New ready process is swapped in to main memory as space becomes available.
3. As process completes, it is moved out of main memory.
4. If none of the processes in memory are ready,
 - Swapped out a block process to intermediate queue of blocked process.
 - Swapped in a ready process from the ready queue.

But swapping is an I/O process, so it also takes time. Instead of remain in idle state of CPU, sometimes it is advantageous to swapped in a ready process and start executing it. The main question arises where to put a new process in the main memory. It must be done in such a way that the memory is utilized properly.

7.2.2 Partitioning

Splitting of memory into sections to allocate processes including operating system. There are two schemes for partitioning:

- Fixed size partitions
- Variable size partitions

7.2.2.1 Fixed sized partitions

The memory is partitioned to fixed size partition. Although the partitions are of fixed size, they need not be of equal size. There is a problem of wastage of memory in fixed size even with unequal size. When a process is brought into memory, it is placed in the smallest

available partition that will hold it. Equal size and unequal size partition for fixed size partitions of main memory is shown in Figure 3.20.

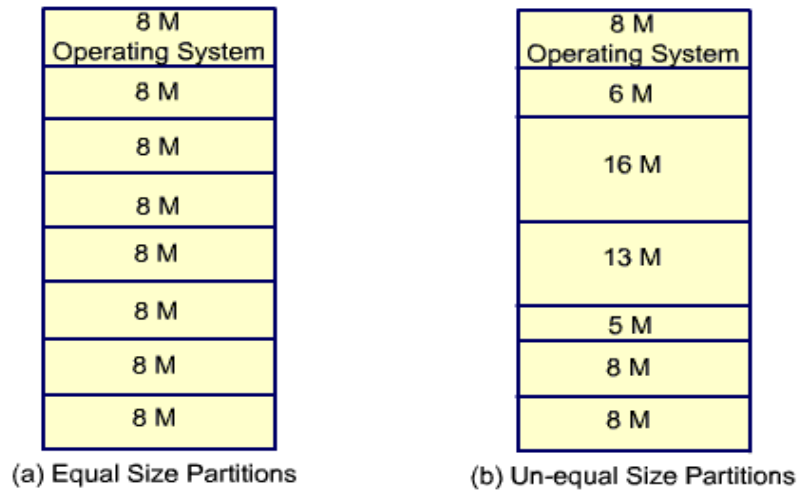

Figure 3.20: Equal and unequal size partition.

Even with the use of unequal size of partitions, there will be wastage of memory. In most cases, a process will not require exactly as much memory as provided by the partition.

For example, a process that require 5-MB of memory would be placed in the 6-MB partition which is the smallest available partition. In this partition, only 5-MB is used, the remaining 1-MB can not be used by any other process, so it is a wastage. Like this, in every partition we may have some unused memory. The unused portion of memory in each partition is termed as hole.

7.2.2.2 Variable size Partition

When a process is brought into memory, it is allocated exactly as much memory as it requires and no more. In this process it leads to a hole at the end of the memory, which is too small to use. It seems that there will be only one hole at the end, so the waste is less.

But this is not the only hole that will be present in variable size partition. When all processes are blocked then swap out a process and bring in another process. The new

swapped in process may be smaller than the swapped-out process. Most likely we will not get two process of same size. So, it will create another whole. If the swap- out and swap-in is occurring more time, then more and more hole will be created, which will lead to more wastage of memory.

There are two simple ways to slightly remove the problem of memory wastage:

Coalesce : Join the adjacent holes into one large hole, so that some process can be accommodated into the hole.

Compaction: From time to time go through memory and move all hole into one free block of memory.

During the execution of process, a process may be swapped in or swapped out many times. it is obvious that a process is not likely to be loaded into the same place in main memory each time it is swapped in. Further more if compaction is used, a process may be shifted while in main memory.

A process in memory consists of instruction plus data. The instruction will contain address for memory locations of two types:

- Address of data item
- Address of instructions used for branching instructions

These addresses will change each time a process is swapped in. To solve this problem, a distinction is made between logical address and physical address.

- Logical address is expressed as a location relative to the beginning of the program. Instructions in the program contains only logical address.
- Physical address is an actual location in main memory.

When the processor executes a process, it automatically converts from logical to physical address by adding the current starting location of the process, called it's base address to each logical address.

Every time the process is swapped in to main memory, the base address may be different depending on the allocation of memory to the process. Consider a main memory of 2-MB out of which 512-KB is used by the Operating System. Consider three process of size 425-KB, 368-KB and 470-KB and these three processes are loaded into the memory. This leaves a hole at the end of the memory. That is too small for a fourth process. At some point none of the process in main memory is ready. The operating system swaps out process-2 which leaves sufficient room for new process of size 320-KB. Since process-4 is smaller then process-2, another hole is created. Later a point is reached at which none of the processes in the main memory is ready, but proces-2, so process-1 is swapped out and process-2 is swapped in there. It will create another hole. In this way it will create lot of small holes in the memory system which will lead to more memory wastage.

The effect of dynamic partitioning that creates more whole during the execution of processes is shown in the Figure 3.21.

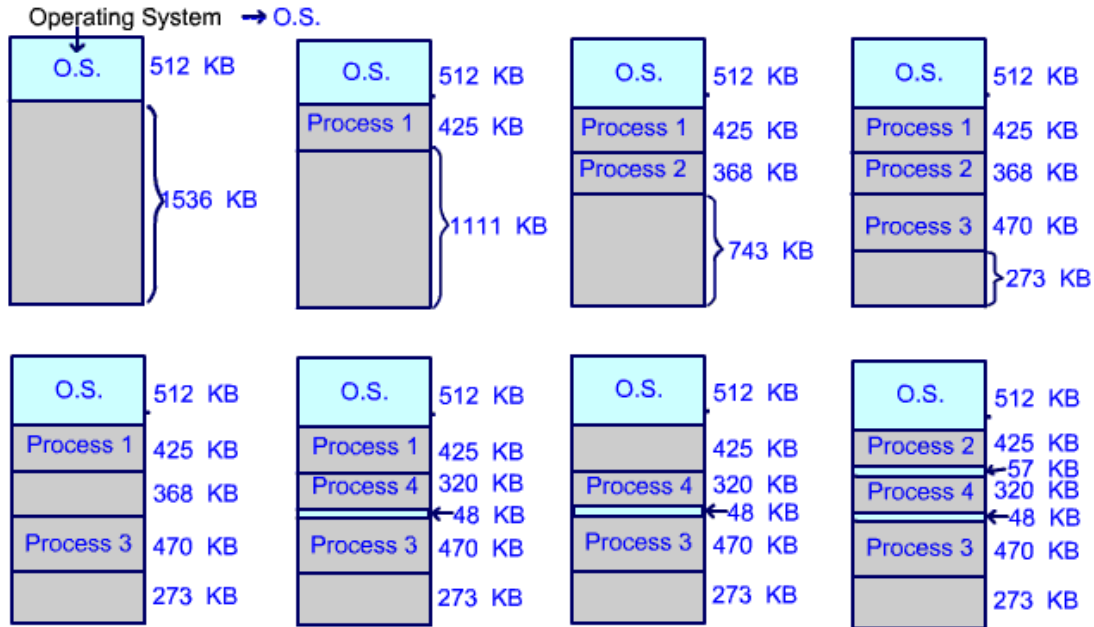

Figure 3.21: The effect of dynamic partitioning



Check your progress I

1. A process in memory consists of instruction plus_____ .
2. The main working principle of digital computer is _____ principle.
3. _____ is a mechanism in which a process can be swapped temporarily out of main memory (or move) to secondary storage (disk) and make that memory available to other processes.
4. _____ is a memory management technique in which each job is divided into several segments of different sizes, one for each module that contains pieces that perform related functions.

7.3 Summary

1. Memory management is the functionality of an operating system which handles or manages primary memory and moves processes back and forth between main memory and disk during execution.
2. The main memory of a computer is divided into two parts. One part is reserved for operating system. The other part is for user program.
3. In a multiprogramming system, the user part of memory is subdivided to accommodate multiple process.
4. The task of subdivision is carried out dynamically by operating system and is known as memory management.
5. When memory holds multiple processes, then the process can move from one process to another process when one process is waiting.
6. The processor alternates between executing operating system instructions and executing user processes.
7. In an uniprogramming system, main memory is divided into two parts: one part for the operating system and the other part for the program currently being executed.
8. The task of subdivision is carried out dynamically by the operating system and is known as memory management.

7.4 Model Questions

1. What is memory management? Why it is required?
2. What are the five states of a process? Explain with the help of a diagram.
3. What are the various possible reasons for the suspension of a process?
4. What is swapping? Explain.
5. Define partitioning of memory space. How many types of partitioning is possible? Explain.
6. What are the simple ways to remove the problem of memory wastage?



Answers to Check your progress I

1. Data
2. Von-Neumann stored program
3. Swapping
4. Segmentation

VIRTUAL MEMORY

8.0 Learning Objectives

After the completion of this unit, the learner shall be able to:

- Define page frames;
 - Differentiate between a logical address and the physical address;
 - Translate logical addresses to physical address;
 - Explain demand paging;
 - Explain the concept of Virtual Memory;
 - Define virtual address space;
 - Perform a virtual address translation scheme by using page table;
-

8.1 Paging

Both unequal fixed size and variable size partitions are inefficient in the use of memory. It has been observed that both schemes lead to memory wastage. Therefore, we are not using the memory efficiently.

There is another scheme for use of memory which is known as paging. In this scheme, the memory is partitioned into equal fixed size chunks that are relatively small. This chunk of memory is known as frames or page frames.

Each process is also divided into small fixed chunks of same size. The chunks of a program are known as pages. A page of a program could be assigned to available page frame. In this scheme, the wastage space in memory for a process is a fraction of a page frame which corresponds to the last page of the program.

At a given point of time some of the frames in memory are in use and some are free. The list of free frames is maintained by the operating system.

Process A, stored in disk, consists of pages. At the time of execution of the process A, the operating system finds six free frames and loads the six pages of the process A into six frames.

These six frames need not be contiguous frames in main memory. The operating system maintains a page table for each process. Within the program, each logical address consists of page number and a relative address within the page. In case of simple partitioning, a logical address is the location of a word relative to the beginning of the program; the processor translates that into a physical address.

With paging, a logical address is a location of the word relative to the beginning of the page of the program, because the whole program is divided into several pages of equal length and the length of a page is same with the length of a page frame.

A logical address consists of page number and relative address within the page, the process uses the page table to produce the physical address which consists of frame number and relative address within the frame.

The Figure 3.22 shows the allocation of frames to a new process in the main memory. A page table is maintained for each process. This page table helps us to find the physical address in a frame which corresponds to a logical address within a process.

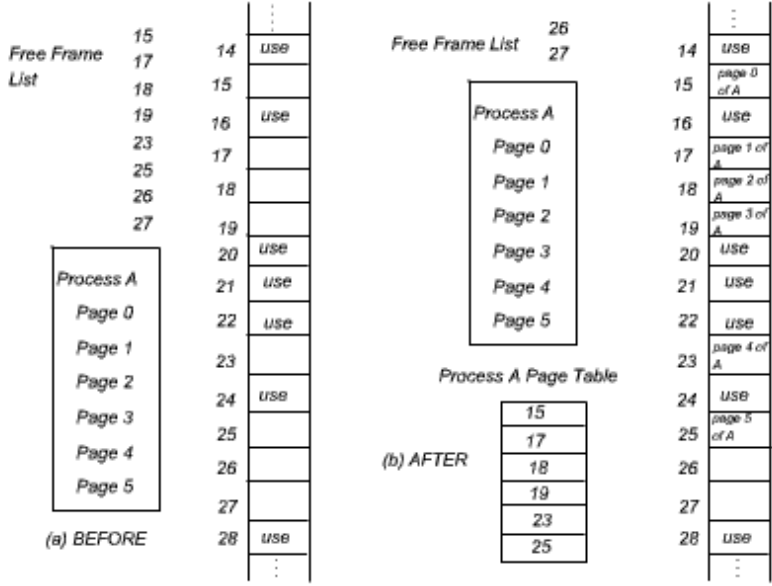

Figure 3.22: Allocation of free frames

The conversion of logical address to physical address is shown in the figure for the Process A.

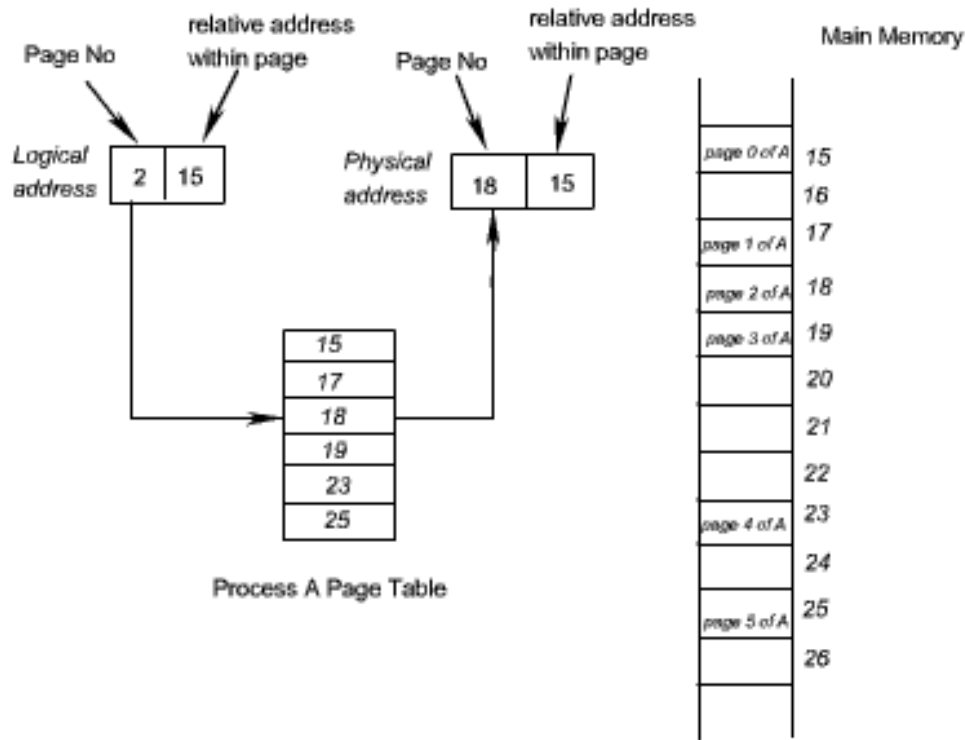

Figure 3.23: Translation of Logical Address to Physical Address

This approach solves the problems. Main memory is divided into many small equal size frames. Each process is divided into frame size pages. Smaller process requires fewer pages, larger process requires more. When a process is brought in, its pages are loaded into available frames and a page table is set up. The translation of logical addresses to physical address is shown in the Figure 3.23.

8.2 Virtual Memory

The concept of paging helps us to develop truly effective multiprogramming systems. Since a process need not be loaded into contiguous memory locations, it helps us to put a page of a process in any free page frame. On the other hand, it is not required to load the

whole process to the main memory, because the execution may be confined to a small section of the program (eg. a subroutine).

It would clearly be wasteful to load in many pages for a process when only a few pages will be used before the program is suspended. Instead of loading all the pages of a process, each page of process is brought in only when it is needed, i.e on demand. This scheme is known as *demand paging*.

Demand paging also allows us to accommodate more process in the main memory, since we are not going to load the whole process in the main memory, pages will be brought into the main memory as and when it is required.

With demand paging, it is not necessary to load an entire process into main memory. This concept leads us to an important consequence – It is possible for a process to be larger than the size of main memory. So, while developing a new process, it is not required to look for the main memory available in the machine. Because, the process will be divided into pages and pages will be brought to memory on demand. Because a process executes only in main memory, so the main memory is referred to as real memory or physical memory.

A programmer or user perceives a much larger memory that is allocated on the disk. This memory is referred to as virtual memory. The program enjoys a huge virtual memory space to develop his or her program or software.

The execution of a program is the job of operating system and the underlying hardware. To improve the performance some special hardware is added to the system. This hardware unit is known as Memory Management Unit (MMU).

In paging system, we make a page table for the process. Page table helps us to find the physical address from virtual address.

The virtual address space is used to develop a process. The special hardware unit, called Memory Management Unit (MMU) translates virtual address to physical address. When

the desired data is in the main memory, the CPU can work with these data. If the data are not in the main memory, the MMU causes the operating system to bring into the memory from the disk. A typical virtual memory organization is shown in the Figure 3.24.

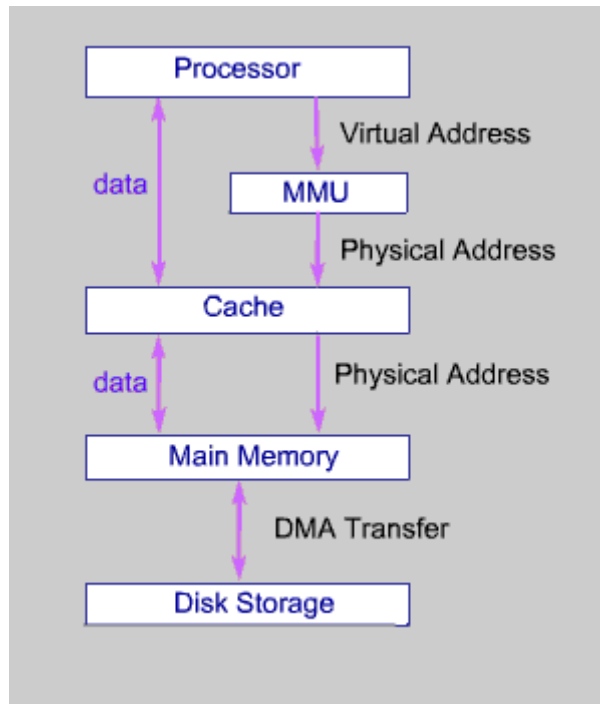

Figure 3.24: Virtual Memory Organization



Check your progress I

1. Because of virtual memory, the memory can be shared among _____.
 - (a) processes
 - (b) threads
 - (c) instructions
 - (d) none of the mentioned
2. _____ is the concept in which a process is copied into the main memory from the secondary memory according to the requirement.
3. Separation of user logical memory and physical memory is _____.
4. The address location in the Main Memory, is referred to as _____.

8.3 Address Translation

The basic mechanism for reading a word from memory involves the translation of a virtual or logical address, consisting of page number and offset, into a physical address, consisting of frame number and offset, using a page table. There is one-page table for each process. But each process can occupy huge amount of virtual memory. But the virtual memory of a process cannot go beyond a certain limit which is restricted by the underlying hardware of the MMU. One of such components may be the size of the virtual address register.

The sizes of pages are relatively small and so the size of page table increases as the size of process increases. Therefore, size of page table could be unacceptably high. To overcome this problem, most virtual memory scheme store page table in virtual memory rather than in real memory.

This means that the page table is subject to paging just as other pages are. When a process is running, at least a part of its page table must be in main memory, including the page table entry of the currently executing page. A virtual address translation scheme by using page table is shown in the Figure 3.25.

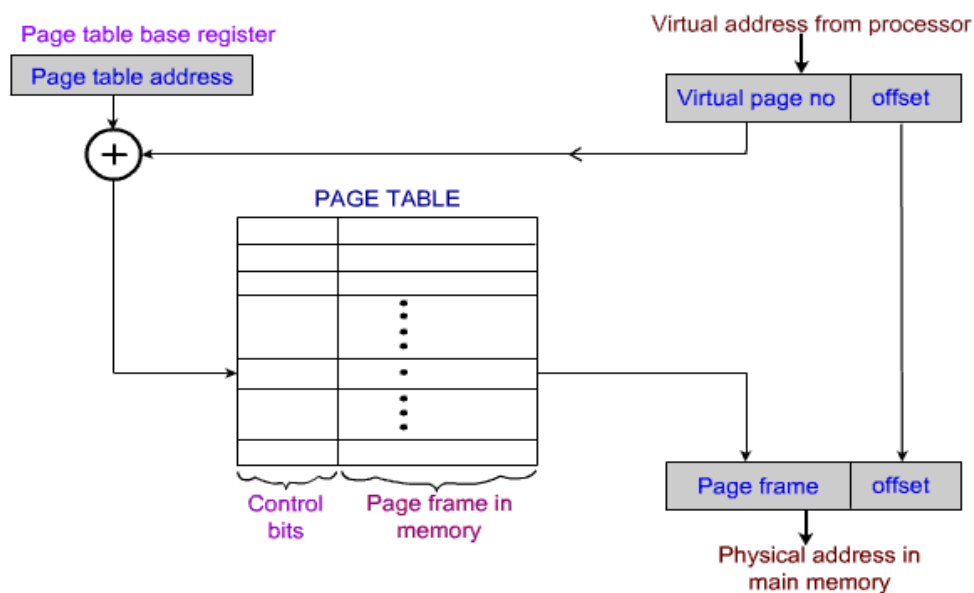

Figure 3.25: Virtual Address Translation Method

Each virtual address generated by the processor is interpreted as virtual page number (high order list) followed by an offset (lower order bits) that specifies the location of a particular word within a page. Information about the main memory location of each page kept in a page table.

Some processors make use of a two level scheme to organize large page tables. In this scheme, there is a page directory, in which each entry points to a page table. Thus, if the length of the page directory is X , and if the maximum length of a page table is Y , then the process can consist of up to $X * Y$ pages. Typically, the maximum length of page table is restricted to the size of one page frame.

8.3.1 Inverted page table structures

There is one entry in the hash table and the inverted page table for each real memory page rather than one per virtual page. Thus, a fixed portion of real memory is required for the page table, regardless of the number of processes or virtual page supported. Because more than one virtual address may map into the hash table entry, a chaining technique is used for managing the overflow. The hashing techniques results in chains that are typically short – either one or two entries. The inverted page table structure for address translation is shown in the Figure 3.26.

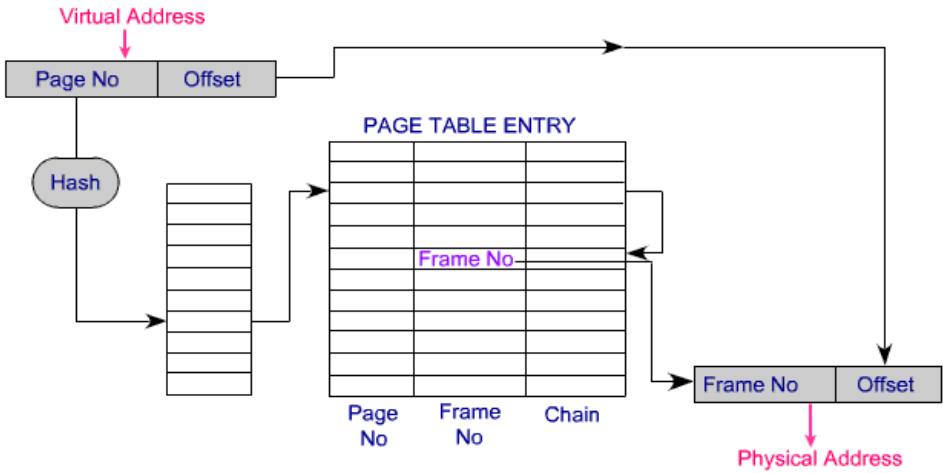

Figure 3.26: Inverted Page table structure

8.3.2 Translation Lookaside Buffer (TLB)

Every virtual memory reference can cause two physical memory accesses. One to fetch the appropriate page table entry One to fetch the desired data. Thus, a straight forward virtual memory scheme would have the effect of doubling the memory access time.

To overcome this problem, most virtual memory schemes make use of a special cache for page table entries, usually called Translation Lookaside Buffer (TLB).

This cache functions in the same way as a memory cache and contains those page table entries that have been most recently used.

In addition to the information that constitutes a page table entry, the TLB must also include the virtual address of the entry.

The Figure 3.27 shows a possible organization of a TLB where the associative mapping technique is used.

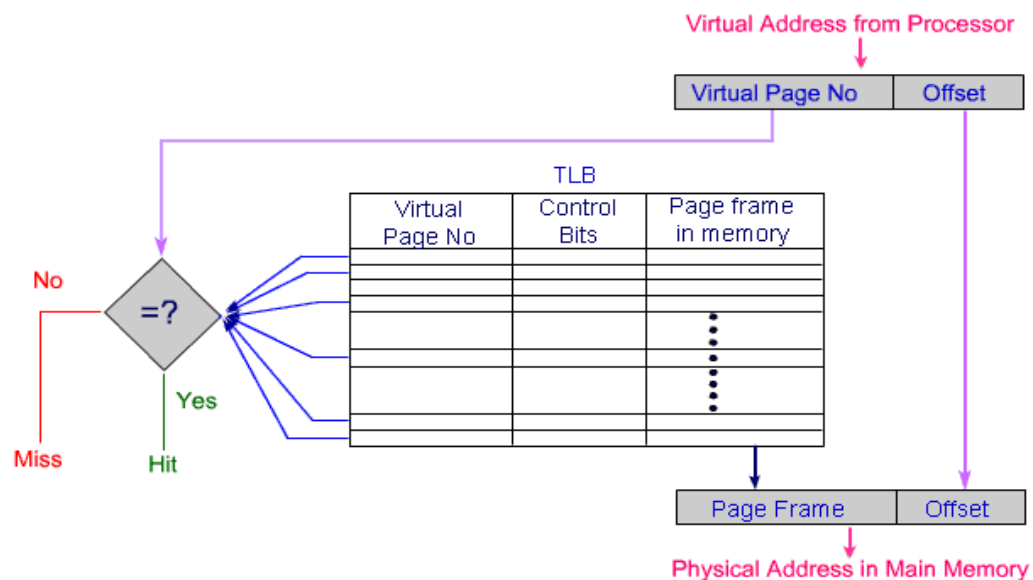

Figure 3.27: Use of an associative mapped TLB

Set-associative mapped TLBs are also found in commercial products. An essential requirement is that the contents of the TLB be coherent with the contents of the page table in the main memory.

When the operating system changes the contents of the page table it must simultaneously invalidate the corresponding entries in the TLB. One of the control bits in the TLB is provided for this purpose.

Address Translation proceeds as follows:

- Given a virtual address, the MMU looks in the TLB for the reference page.
- If the page table entry for this page is found in the TLB, the physical address is obtained immediately.
- If there is a miss in the TLB, then the required entry is obtained from the page table in the main memory and the TLB is updated.
- When a program generates an access request to a page that is not in the main memory, a page fault is said to have occurred.
- The whole page must be brought from the disk into the memory before access can proceed.
- When it detects a page fault, the MMU asks the operating system to intervene by raising an exception (interrupt).
- Processing of active task is interrupted, and control is transferred to the operating system.
- The operating system then copies the requested page from the disk into the main memory and returns control to the interrupted task. Because a long delay occurs due to a page transfer takes place, the operating system may suspend execution of the task that caused the page fault and begin execution of another task whose page are in the main memory.



Check your progress II

1. In FIFO page replacement algorithm, when a page must be replaced _____.
 - (a) oldest page is chosen
 - (b) newest page is chosen
 - (c) random page is chosen
 - (d) none of the mentioned
2. Which algorithm chooses the page that has not been used for the longest period of time whenever the page required to be replaced?
 - (a) first in first out algorithm
 - (b) additional reference bit algorithm
 - (c) least recently used algorithm
 - (d) counting based page replacement algorithm
3. LRU stands for _____.
4. Demand paged memory allocation
 - (a) allows the virtual address space to be independent of the physical memory
 - (b) allows the virtual address space to be a multiple of the physical memory size
 - (c) allows deadlock to be detected in paging schemes
 - (d) None of the above

8.4 Summary

1. The idea of virtual memory is to create a virtual address space that doesn't correspond to actual addresses in RAM.
2. We break virtual memory into chunks called pages; a typical page size is four kilobytes. We also break RAM into page frames, each the same size as a page, ready to hold any page of virtual memory.
3. The system also maintains a page table, stored in RAM, which is an array of entries, one for each page, storing information about the page.

4. Whenever a program requests access to a memory address, the CPU will always work with this as a virtual memory address, and it will need somehow to find where the data is actually loaded. The CPU goes through the following process.
 - a. The CPU breaks the address into the first three bits giving the page number page, and the last twelve bits giving the offset offs within the page.
 - b. The CPU looks into the page table at index page to find which page frame f contains the page.
 - c. If the page entry says that the page is not in RAM, it initiates a page fault. This is an exception telling the operating system that it needs to bring a page into memory. After the operating system's exception handler finishes, it returns back to the same instruction so the CPU ends up trying the instruction over again.
 - d. Otherwise, the CPU loads from the memory address offs within page frame f.
5. The page table is the primary data structure for holding information about each page in memory.
6. One of the most important issues in virtual memory is the paging algorithm. For the success of a virtual memory system, we need an algorithm that minimizes the number of page faults on typical request sequences while simultaneously requiring very little computation.
7. With the FIFO algorithm, any page fault results in throwing out the oldest page in memory to make room for the new page.
8. The LRU algorithm says that the system should always eject the page that was least recently used. A page that has been used recently, after all, is likely to be used again in the near future, so we should not eject such a page.

8.5 Model Questions

1. What do you mean by memory hierarchy? The three characteristics of memory: cost, capacity and access time are related to each other as one goes down the memory hierarchy?

2. What is virtual memory? Explain the need for virtual memory.
3. Explain about LRU page replacement algorithm.
4. What is physical address and logical address? Explain.
5. Explain with the help of a diagram how virtual address can be mapped into physical address using mapping.
6. Differentiate virtual memory with cache memory.
7. What is page fault? How it is handled?
8. Explain briefly about paging and segmentation concept in memory organization.
9. What is address translation page fault routine, page fault and demand paging?
10. What is TLB?
11. Discuss how paging helps in implementing virtual memory.
12. Explain the virtual memory translation and TLB with necessary diagram.



Answers to Check your progress I

1. A
2. Demand Paging
3. Virtual Memory
4. Physical Address



Answers to Check your progress II

1. A
2. C
3. Least Recently Used
4. A

INSTRUCTION SET AND ADDRESSING

9.0 Learning Objectives

After completing this unit, the learner shall be able to:

- Explain common addressing techniques;
- Define the instruction set of a computer;
- Explain displacement addressing;
- Define Machine Instructions;
- Know the elements of an instruction;
- Explain Instruction Representation;
- Explain the various Instruction Types;
- Know the important and fundamental design issues of an Instruction;
- Categorize the various types of operands;
- Categorize the various types of operations;

9.1 Addressing Modes

We have examined the types of operands and operations that may be specified by machine instructions. Now we have to see how is the address of an operand specified, and how are the bits of an instruction organized to define the operand addresses and operation of that instruction. The most common addressing techniques are:

- Immediate
- Direct
- Indirect
- Register
- Register Indirect
- Displacement
- Stack

All computer architectures provide more than one of these addressing modes. The question arises as to how the control unit can determine which addressing mode is being used in a

particular instruction. Several approaches are used. Often, different opcodes will use different addressing modes. Also, one or more bits in the instruction format can be used as a mode field. The value of the mode field determines which addressing mode is to be used.

What is the interpretation of effective address? In a system without virtual memory, the effective address will be either a main memory address or a register. In a virtual memory system, the effective address is a virtual address or a register. The actual mapping to a physical address is a function of the paging mechanism and is invisible to the programmer.

To explain the addressing modes, we use the following notation:

- A** = contents of an address field in the instruction that refers to a memory
- R** = contents of an address field in the instruction that refers to a register
- EA** = actual (effective) address of the location containing the referenced operand
- (X)** = contents of location X

9.1.1 Immediate Addressing

The simplest form of addressing is immediate addressing, in which the operand is actually present in the instruction:

OPERAND = A

This mode can be used to define and use constants or set initial values of variables. The advantage of immediate addressing is that no memory reference other than the instruction fetch is required to obtain the operand. The disadvantage is that the size of the number is restricted to the size of the address field, which, in most instruction sets, is small compared with the word length.



Figure 4.1: Immediate Addressing Mode

The instruction format for Immediate Addressing Mode is shown in the Figure 4.1.

9.1.2 Direct Addressing

A very simple form of addressing is direct addressing, in which the address field contains the effective address of the operand:

$$EA = A$$

It requires only one memory reference and no special calculation.

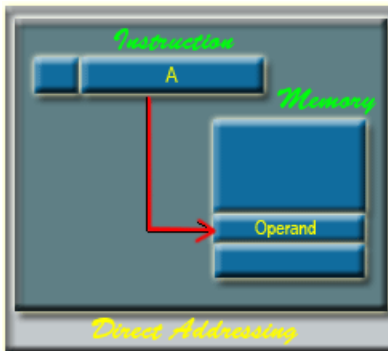

Figure 4.2: Direct Addressing Mode

The fetching of data from the memory location in case of direct addressing mode is shown in the Figure 4.2. Here, 'A' indicates the memory address field for the operand

9.1.3 Indirect Addressing

With direct addressing, the length of the address field is usually less than the word length, thus limiting the address range. One solution is to have the address field refer to the address of a word in memory, which in turn contains a full-length address of the operand. This is known as indirect addressing:

$$EA = (A)$$

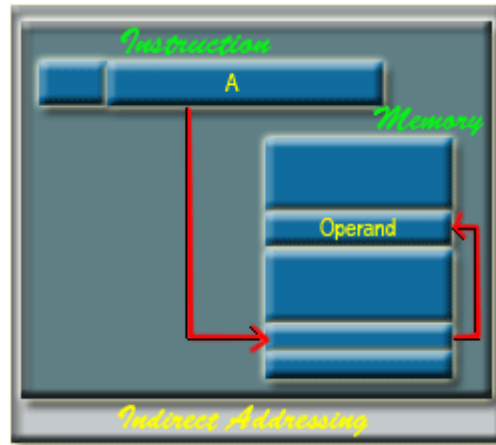

Figure 4.3: Indirect Addressing Mode

The exact memory location of the operand in case of indirect addressing mode is shown in the Figure 4.2. Here 'A' indicates the memory address field of the required operands

9.1.4 Register Addressing

Register addressing is similar to direct addressing. The only difference is that the address field refers to a register rather than a main memory address:

$$EA = R$$

The advantages of register addressing are that only a small address field is needed in the instruction and no memory reference is required. The disadvantage of register addressing is that the address space is very limited.

The exact register location of the operand in case of Register Addressing Mode is shown in the Figure 4.4. Here, 'R' indicates a register where the operand is present.

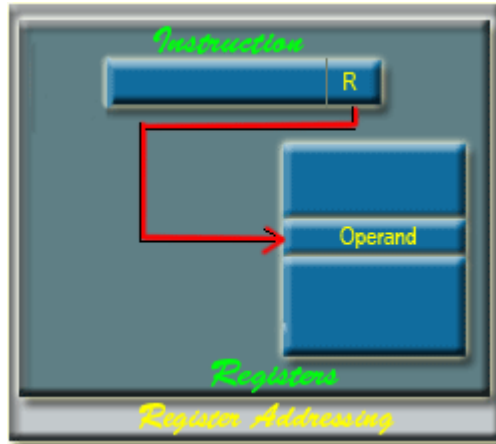

Figure 4.4: Register Addressing Mode.

9.1.5 Register Indirect Addressing

Register indirect addressing is similar to indirect addressing, except that the address field refers to a register instead of a memory location. It requires only one memory reference and no special calculation.

$$EA = (R)$$

Register indirect addressing uses one less memory reference than indirect addressing. Because, the first information is available in a register which is nothing but a memory address. From that memory location, we use to get the data or information. In general, register access is much faster than the memory access.

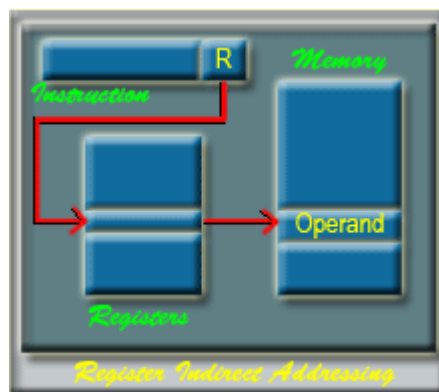

9.1.6 Displacement Addressing

A very powerful mode of addressing combines the capabilities of direct addressing and register indirect addressing, which is broadly categorized as displacement addressing:

$$EA = A + (R)$$

Displacement addressing requires that the instruction have two address fields, at least one of which is explicit. The value contained in one address field (value = A) is used directly. The other address field, or an implicit reference based on opcode, refers to a register whose contents are added to A to produce the effective address. The general format of Displacement Addressing is shown in the Figure 4.6.

Three of the most common use of displacement addressing are:

- Relative addressing
- Base-register addressing
- Indexing

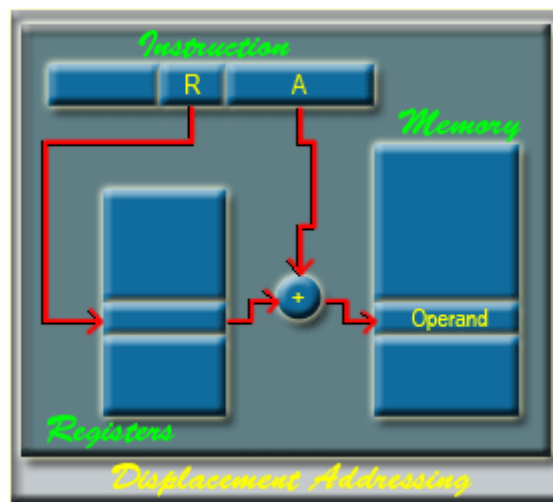

Figure 4.6: Displacement Addressing

9.1.6.1 Relative Addressing

For relative addressing, the implicitly referenced register is the program counter (PC). That is, the current instruction address is added to the address field to produce the EA. Thus, the effective address is a displacement relative to the address of the instruction.

9.1.6.2 Base-Register Addressing

The reference register contains a memory address, and the address field contains a displacement from that address. The register reference may be explicit or implicit. In some implementation, a single segment/base register is employed and is used implicitly. In others, the programmer may choose a register to hold the base address of a segment, and the instruction must reference it explicitly.

9.1.6.3 Indexing

The address field references a main memory address, and the reference register contains a positive displacement from that address. In this case also the register reference is sometimes explicit and sometimes implicit.

Generally, index register are used for iterative tasks, it is typical that there is a need to increment or decrement the index register after each reference to it. Because this is such a common operation, some system will automatically do this as part of the same instruction cycle.

This is known as auto-indexing. We may get two types of auto-indexing:

- one is auto-incrementing and the other one is
- auto-decrementing.

If certain registers are devoted exclusively to indexing, then auto-indexing can be invoked implicitly and automatically. If general purpose register are used, the auto-index operation may need to be signaled by a bit in the instruction.

Auto-indexing using increment can be depicted as follows:

$$EA = A + (R)$$

$$R = (R) + 1$$

Auto-indexing using decrement can be depicted as follows:

$$EA = A + (R)$$

$$R = (R) - 1$$

In some machines, both indirect addressing and indexing are provided, and it is possible to employ both in the same instruction. There are two possibilities: The indexing is performed either before or after the indirection.

If indexing is performed after the indirection, it is termed post-indexing

$$EA = (A) + (R)$$

First, the contents of the address field are used to access a memory location containing an address. This address is then indexed by the register value.

With pre-indexing, the indexing is performed before the indirection:

$$EA = (A + (R))$$

An address is calculated, the calculated address contains not the operand, but the address of the operand.

9.6.1.4 Stack Addressing

A stack is a linear array or list of locations. It is sometimes referred to as a pushdown list or last in-first-out queue. A stack is a reserved block of locations. Items are appended to the top of the stack so that, at any given time, the block is partially filled. Associated with

the stack is a pointer whose value is the address of the top of the stack. The stack pointer is maintained in a register. Thus, references to stack locations in memory are in fact register indirect addresses.

The stack mode of addressing is a form of implied addressing. The machine instructions need not include a memory reference but implicitly operate on the top of the stack.



Check your progress I

1. In _____ addressing mode, the operand is specified in the instruction itself.
2. In _____ addressing mode the operand is stored in the register and this register is present in CPU.
3. In _____ addressing mode the register contains the address of operand rather than the operand itself.
4. In _____ addressing mode effective address of operand is present in instruction itself.
5. In _____ addressing mode the address field of instruction gives the address where the effective address is stored in memory.
6. In _____ addressing the contents of the indexed register is added to the Address part of the instruction, to obtain the effective address of operand.

9.2 Machine Instruction

The operation of a CPU is determined by the instruction it executes, referred to as machine instructions or computer instructions. The collection of different instructions is referred as the *instruction set of the CPU*.

Each instruction must contain the information required by the CPU for execution. The elements of an instruction are as follows:

- a. **Operation Code:** Specifies the operation to be performed (e.g., add, move etc.). The operation is specified by a binary code, known as the operation code or opcode.
- b. **Source operand reference:** The operation may involve one or more source operands; that is, operands that are inputs for the operation.
- c. **Result operand reference:** The operation may produce a result.
- d. **Next instruction reference:** This tells the CPU where to fetch the next instruction after the execution of this instruction is complete.

The next instruction to be fetched is located in main memory. But in case of virtual memory system, it may be either in main memory or secondary memory (disk). In most cases, the next instruction to be fetched immediately follows the current instruction. In those cases, there is no explicit reference to the next instruction. When an explicit reference is needed, then the main memory or virtual memory address must be given.

Source and result operands can be in one of the three areas:

- main or virtual memory,
- CPU register or
- I/O device.

The steps involved in instruction execution is shown in the Figure 4.7.

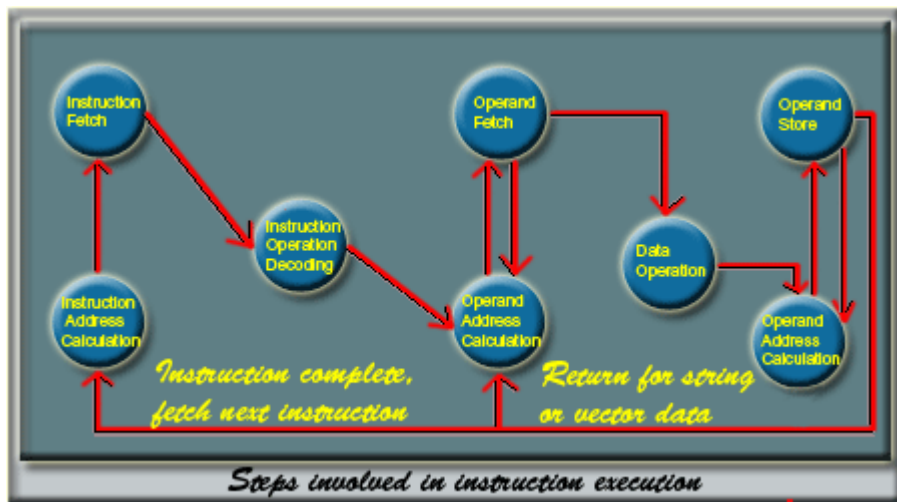

Figure 4.7: Steps involved in instruction execution

9.3 Instruction Representation

Within the computer, each instruction is represented by a sequence of bits. The instruction is divided into fields, corresponding to the constituent elements of the instruction. The

instruction format is highly machine specific and it mainly depends on the machine architecture. A simple example of an instruction format is shown in the Figure 4.8. It is assumed that it is a 16-bit CPU. 4 bits are used to provide the operation code. So, we may have to 16($2^4=16$) different set of instructions. With each instruction, there are two operands. To specify each operand, 6 bits are used. It is possible to provide 64 ($2^6 = 64$) different operands for each operand reference.

It is difficult to deal with binary representation of machine instructions. Thus, it has become common practice to use a symbolic representation of machine instructions.

Opcodes are represented by abbreviations, called mnemonics, that indicate the operations. Common examples include:

ADD	Add
SUB	Subtract
MULT	Multiply
DIV	Division
LOAD	Load data from memory to CPU
STORE	Store data to memory from CPU.

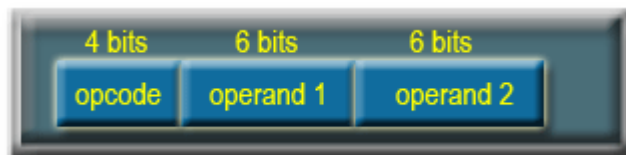

Figure 4.8: A simple instruction format

Operands are also represented symbolically. For example, the instruction

MULT R, X ; $R \leftarrow R * X$

may mean multiply the value contained in the data location X by the contents of register R and put the result in register R

In this example, X refers to the address of a location in memory and R refers to a particular register.

Thus, it is possible to write a machine language program in symbolic form. Each symbolic opcode has a fixed binary representation, and the programmer specifies the location of each symbolic operand.

9.4 Instruction Types

The instruction set of a CPU can be categorized as follows:

9.4.1 Data Processing:

Arithmetic and Logic instructions: Arithmetic instructions provide computational capabilities for processing numeric data. Logic (Boolean) instructions operate on the bits of a word as bits rather than as numbers. Logic instructions thus provide capabilities for processing any other type of data. These operations are performed primarily on data in CPU registers.

9.4.2 Data Storage:

Memory instructions are used for moving data between memory and CPU registers.

9.4.3 Data Movement:

I/O instructions are needed to transfer program and data into memory from storage device or input device and the results of computation back to the user.

9.4.4 Control:

Test and branch instructions: Test instructions are used to test the value of a data word or the status of a computation. Branch instructions are then used to branch to a different set of instructions depending on the decision made.

9.5 Number of Addresses

What is the maximum number of addresses one might need in an instruction? Most of the arithmetic and logic operations are either unary (one operand) or binary (two operands). Thus, we need a maximum of two addresses to reference operands. The result of an operation must be stored, suggesting a third address. Finally, after completion of an instruction, the next instruction must be fetched, and its address is needed.

This reasoning suggests that an instruction may require to contain four address references: two operands, one result, and the address of the next instruction. In practice, four address instructions are rare. Most instructions have one, two or three operands addresses, with the address of the next instruction being implicit (obtained from the program counter).

9.6 Instruction Set Design

One of the most interesting, and most analyzed, aspects of computer design is instruction set design. The instruction set defines the functions performed by the CPU. The instruction set is the programmer's means of controlling the CPU. Thus, programmer requirements must be considered in designing the instruction set. Most important and fundamental design issues:

- Operation repertoire : How many and which operations to provide, and how complex operations should be.
- Data Types : The various type of data upon which operations are performed.
- Instruction format : Instruction length (in bits), number of addresses, size of various fields and so on.
- Registers : Number of CPU registers that can be referenced by instructions and their use.
- Addressing : The mode or modes by which the address of an operand is specified.

9.7 Types of Operands

Machine instructions operate on data. Data can be categorized as follows:

Addresses: It basically indicates the address of a memory location. Addresses are nothing but the unsigned integer, but treated in a special way to indicate the address of a memory location. Address arithmetic is somewhat different from normal arithmetic and it is related to machine architecture.

Numbers: All machine languages include numeric data types. Numeric data are classified into two broad categories: integer or fixed point and floating point.

Characters: A common form of data is text or character strings. Since computer works with bits, so characters are represented by a sequence of bits. The most commonly used coding scheme is ASCII (American Standard Code for Information Interchange) code.

Logical Data: Normally each word or other addressable unit (byte, halfword, and so on) is treated as a single unit of data. It is sometime useful to consider an n -bit unit as consisting of n 1-bit items of data, each item having the value 0 or 1. When data are viewed this way, they are considered to be logical data. Generally, 1 is treated as true and 0 is treated as false.

9.8 Types of Operations

The number of different opcodes and their types varies widely from machine to machine. However, some general type of operations is found in most of the machine architecture. Those operations can be categorized as follows:

- Data Transfer
- Arithmetic
- Logical
- Conversion
- Input Output [I/O]
- System Control

- Transfer Control

9.8.1 Data Transfer

The most fundamental type of machine instruction is the data transfer instruction. The data transfer instruction must specify several things. First, the location of the source and destination operands must be specified. Each location could be memory, a register, or the top of the stack. Second, the length of data to be transferred must be indicated. Third, as with all instructions with operands, the mode of addressing for each operand must be specified. The CPU has to perform several tasks to accomplish a data transfer operation. If both source and destination are registers, then the CPU simply causes data to be transferred from one register to another; this is an operation internal to the CPU. If one or both operands are in memory, then the CPU must perform some or all of the following actions:

- Calculate the memory address, based on the addressing mode.
- If the address refers to virtual memory, translate from virtual to actual memory address.
- Determine whether the addressed item is in cache.
- If not, issue a command to the memory module.

Commonly used data transfer operation

Operation Name	Description
Move (Transfer)	Transfer word or block from source to destination
Store	Transfer word from processor to memory
Load (fetch)	Transfer word from memory to processor
Exchange	Swap contents of source and destination
Clear (reset)	Transfer word of 0s to destination
Set	Transfer word of 1s to destination
Push	Transfer word from source to top of stack
Pop	Transfer word from top of stack to destination

9.8.2 Arithmetic

Most machines provide the basic arithmetic operations like add, subtract, multiply, divide etc. These are invariably provided for signed integer (fixed-point) numbers. They are also available for floating point number. The execution of an arithmetic operation may involve data transfer operation to provide the operands to the ALU input and to deliver the result of the ALU operation.

Commonly used data transfer operations

Operation Name	Description
Add	Compute sum of two operands
Subtract	Compute difference of two operands
Multiply	Compute product of two operands
Divide	Compute quotient of two operands
Absolute	Replace operand by its absolute value
Negate	Change sign of operand
Increment	Add 1 to operand
Decrement	Subtract 1 from operand

9.8.3 Logical

Most machines also provide a variety of operations for manipulating individual bits of a word or other addressable units. Most commonly available logical operations are:

Operation Name	Description
AND	Performs the logical operation AND bitwise
OR	Performs the logical operation OR bitwise
NOT	Performs the logical operation NOT bitwise
Exclusive OR	Performs the specified logical operation Exclusive-OR bitwise

Test	Test specified condition; set flag(s) based on outcome
Compare	Make logical or arithmetic comparison Set flag(s) based on outcome
Set Control Variables	Class of instructions to set controls for protection purposes, interrupt handling, timer control etc.
Shift	Left (right) shift operand, introducing constant at end
Rotate	Left (right) shift operation, with wraparound end

9.8.4 Conversion

Conversion instructions are those that change the format or operate on the format of data. An example is converting from decimal to binary.

9.8.5 Input/Output

Input/Output instructions are used to transfer data between input/output devices and memory/CPU register. Commonly available I/O operations are:

Operation Name	Description
Input (Read)	Transfer data from specified I/O port or device to destination (e.g., main memory or processor register)
Output (Write)	Transfer data from specified source to I/O port or device.
Start I/O	Transfer instructions to I/O processor to initiate I/O operation.
Test I/O	Transfer status information from I/O system to specified destination

9.8.6 System Control

System control instructions are those which are used for system setting and it can be used only in privileged state. Typically, these instructions are reserved for the use of operating systems. For example, a system control instruction may read or alter the content of a control register. Another instruction may be to read or modify a storage protection key.

9.8.7 Transfer of Control

In most of the cases, the next instruction to be performed is the one that immediately follows the current instruction in memory. Therefore, program counter helps us to get the next instruction. But sometimes it is required to change the sequence of instruction execution and for that instruction set should provide instructions to accomplish these tasks. For these instructions, the operation performed by the CPU is to upload the program counter to contain the address of some instruction in memory. The most common transfer-of-control operations found in instruction set are: branch, skip and procedure call.

9.8.8 Branch Instruction

A branch instruction, also called a jump instruction, has one of its operands as the address of the next instruction to be executed. Basically, there are two types of branch instructions: Conditional Branch instruction and unconditional branch instruction. In case of unconditional branch instruction, the branch is made by updating the program counter to address specified in operand. In case of conditional branch instruction, the branch is made only if a certain condition is met. Otherwise, the next instruction in sequence is executed. There are two common ways of generating the condition to be tested in a conditional branch instruction. First most machines provide a 1-bit or multiple-bit condition code that is set as the result of some operations. As an example, an arithmetic operation could set a 2-bit condition code with one of the following four values: zero, positive, negative and overflow. On such a machine, there could be four different conditional branch instructions:

```
BRP X ; Branch to location X if result is positive
BRN X ; Branch to location X if result is negative
BRZ X ; Branch to location X if result is zero
BRO X ; Branch to location X if overflow occurs
```

In all of these cases, the result referred to is the result of the most recent operation that set the condition code.

Another approach that can be used with three address instruction formats is to perform a comparison and specify a branch in the same instruction.

For example,

BRE R1, R2, X ; Branch to X if contents of R1 = Contents of R2.

9.8.9 Skip Instruction

Another common form of transfer-of-control instruction is the skip instruction. Generally, the skip implies that one instruction to be skipped; thus, the implied address equals the address of the next instruction plus one instruction length. A typical example is the increment-and-skip-if-zero (ISZ) instruction. For example,

ISZ R1

This instruction will increment the value of the register R1. If the result of the increment is zero, then it will skip the next instruction.

9.8.10 Procedure Call Instruction

A procedure is a self-contained computer program that is incorporated into a large program. At any point in the program the procedure may be invoked, or called. The processor is instructed to go and execute the entire procedure and then return to the point from which the call took place. The procedure mechanism involves two basic instructions: a call instruction that branches from the present location to the procedure, and a return instruction that returns from the procedure to the place from which it was called. Both of these are forms of branching instructions. Some important points regarding procedure call:

- A procedure can be called from more than one location.
- A procedure call can appear in a procedure. This allows the nesting of procedures to an arbitrary depth.
- Each procedure call is matched by a return in the called program.

Since we can call a procedure from a variety of points, the CPU must somehow save the return address so that the return can take place appropriately. There are three common places for storing the return address:

- Register

- Start of procedure
- Top of stack

Consider a machine language instruction CALL X, which stands for call procedure at location X. If the register approach is used, CALL X causes the following actions:

$$\begin{aligned} \text{RN} &\leftarrow \text{PC} + \text{IL} \\ \text{PC} &\leftarrow \text{X} \end{aligned}$$

where RN is a register that is always used for this purpose, PC is the program counter and IL is the instruction length. The called procedure can now save the contents of RN to be used for the later return.

A second possibilities is to store the return address at the start of the procedure. In this case, CALL X causes

$$\begin{aligned} \text{X} &\leftarrow \text{PC} + \text{IL} \\ \text{PC} &\leftarrow \text{X} + 1 \end{aligned}$$

Both of these approaches have been used. The only limitation of these approaches is that they prevent the use of reentrant procedures. A reentrant procedure is one in which it is possible to have several calls open to it at the same time.

A more general approach is to use stack. When the CPU executes a call, it places the return address on the stack. When it executes a return, it uses the address on the stack.

It may happen that, the called procedure might have to use the processor registers. This will overwrite the contents of the registers and the calling environment will lose the information. So, it is necessary to preserve the contents of processor register too along with the return address. The stack is used to store the contents of processor register. On return from the procedure call, the contents of the stack will be popped out to appropriate registers.

In addition to provide a return address, it is also often necessary to pass parameters with a procedure call. The most general approach to parameter passing is the stack. When the processor executes a call, it not only stacks the return address, it stacks parameters to be passed to the called procedures. The called procedure can access the parameters from the stack. Upon return, return parameters can also be placed on the stack. The entire set of parameters, including return address, that is stored for a procedure invocation is referred to as stack frame.

Most commonly used transfer of control operation:

Operation Name	Description
Jump (branch)	Unconditional transfer, load PC with specific address
Jump conditional	Test specific condition; either load PC with specific address or do nothing, based on condition
Jump to subroutine	Place current program control information in known location; jump to specific address
Return	Replace contents of PC and other register from known location
Skip	Increment PC to skip next instruction
Skip Conditional	Test specified condition; either skip or do nothing based on condition
Halt	Stop program execution

9.9 Instruction Format

An instruction format defines the layout of the bits of an instruction, in terms of its constituents' parts. An instruction format must include an opcode and, implicitly or explicitly, zero or more operands. Each explicit operand is referenced using one of the addressing modes that is available for that machine. The format must, implicitly or explicitly, indicate the addressing mode of each operand. For most instruction sets, more than one instruction format is used. Four common instruction formats are shown in the Figure 4.9.

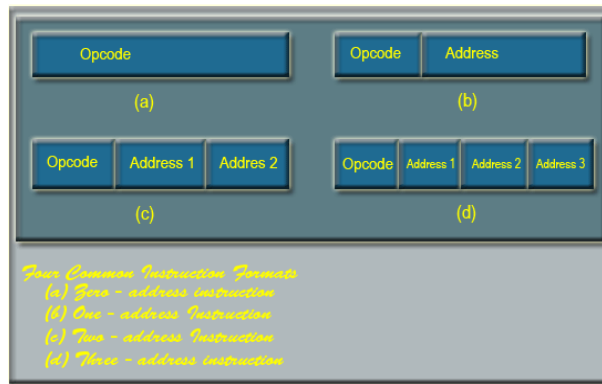

Figure 4.9: Four common Instruction formats

9.9.1 Instruction Length

On some machines, all instructions have the same length; on others there may be many different lengths. Instructions may be shorter than, the same length as, or more than the word length. Having all the instructions be the same length is simpler and make decoding easier but often wastes space, since all instructions then have to be as long as the longest one. Possible relationship between instruction length and word length is shown in the Figure 4.10.

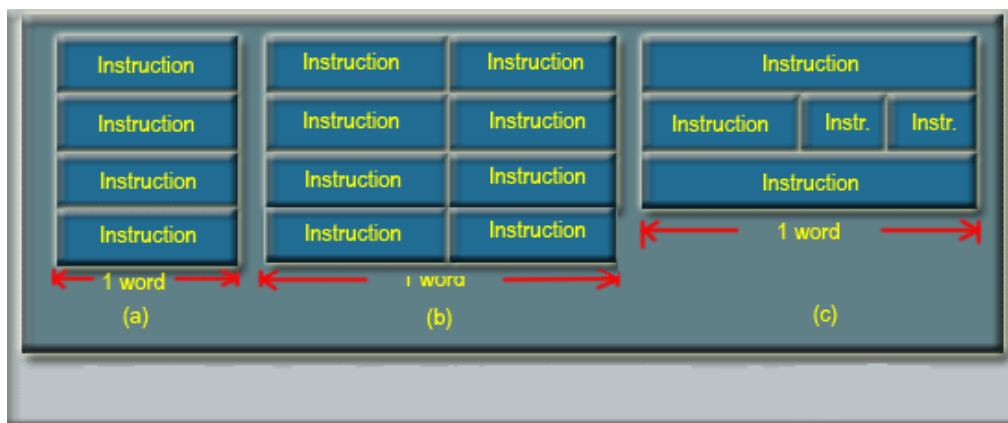

Figure 4.10: Some Possible relationship between instructions and word length

Generally, there is a correlation between memory transfer length and the instruction length. Either the instruction length should be equal to the memory transfer length or one should

be a multiple of the other. Also, in most of the case there is a correlation between memory transfer length and word length of the machine.

9.9.2 Allocation of Bits

For a given instruction length, there is a clearly a trade-off between the number of opcodes and the power of the addressing capabilities. More opcodes obviously mean more bits in the opcode field. For an instruction format of a given length, this reduces the number of bits available for addressing. The following interrelated factors go into determining the use of the addressing bits:

Number of Addressing modes: Sometimes an addressing mode can be indicated implicitly. In other cases, the addressing mode must be explicit, and one or more bits will be needed.

Number of Operands: Typical instructions on today's machines provide for two operands. Each operand address in the instruction might require its own mode indicator, or the use of a mode indicator could be limited to just one of the address field.

Register versus memory: A machine must have registers so that data can be brought into the CPU for processing. With a single user-visible register (usually called the accumulator), one operand address is implicit and consumes no instruction bits. Even with multiple registers, only a few bits are needed to specify the register. The more that registers can be used for operand references, the fewer bits are needed.

Number of register sets: A number of machines have one set of general-purpose registers, with typically 8 or 16 registers in the set. These registers can be used to store data and can be used to store addresses for displacement addressing. The trend recently has been away from one bank of general-purpose registers and toward a collection of two or more specialized sets (such as data and displacement).

Address range: For addresses that reference memory, the range of addresses that can be referenced is related to the number of address bits. With displacement addressing, the range is opened up to the length of the address register.

Address granularity: In a system with 16- or 32-bit words, an address can reference a word or a byte at the designer's choice. Byte addressing is convenient for character manipulation but requires, for a fixed size memory, more address bits.

Variable-Length Instructions: Instead of looking for fixed length instruction format, designer may choose to provide a variety of instructions formats of different lengths. This tactic makes it easy to provide a large repertoire of opcodes, with different opcode lengths. Addressing can be more flexible, with various combinations of register and memory references plus addressing modes. With variable length instructions, many variations can be provided efficiently and compactly. The principal price to pay for variable length instructions is an increase in the complexity of the CPU.

Number of addresses: The processor architecture is described in terms of the number of addresses contained in each instruction. Most of the arithmetic and logic instructions will require more operands. All arithmetic and logic operations are either unary

(one source operand, e.g. NOT) or binary (two source operands, e.g. ADD).

Thus, we need a maximum of two addresses to reference source operands. The result of an operation must be stored, suggesting a third reference. Three address instruction formats are not common because they require a relatively long instruction format to hold the three-address reference. With two address instructions, and for binary operations, one address must do double duty as both an operand and a result. In one address instruction format, a second address must be implicit for a binary operation. For implicit reference, a processor register is used and it is termed as accumulator (AC). the accumulator contains one of the operands and is used to store the result. Consider a simple arithmetic expression to evaluate:

$$Y = (A + B) / (C * D)$$

<u>Instruction</u>	<u>Comment</u>
ADD Y, A, B	$Y \leftarrow A + B$
MULT Z, C, D	$Z \leftarrow C * D$
DIV Y, Y, Z	$Y \leftarrow Y / Z$

Three - address instructions

Figure 4.11: Three address instructions

<u>Instruction</u>	<u>Comment</u>
MOV Y, A	$Y \leftarrow A$
ADD Y, B	$Y \leftarrow Y + B$
MOV Z, C	$Z \leftarrow C$
MULT Z, D	$Z \leftarrow Z * D$
DIV Y, Z	$Y \leftarrow Y / Z$

Two - address instructions

Figure 4.12: Two address instructions

<u>Instruction</u>	<u>Comment</u>
LOAD C	$AC \leftarrow C$
MULT D	$AC \leftarrow AC * D$
STORE Y	$Y \leftarrow AC$
LOAD A	$AC \leftarrow A$
ADD B	$AC \leftarrow AC + B$
DIV Y	$AC \leftarrow AC / Y$
STORE Y	$Y \leftarrow AC$

One - address instructions

Figure 4.13: One address instruction



Check your progress II

1. _____ instructions are responsible for moving data around inside the processor as well as bringing in data or sending data out.
2. _____ control instructions are those which are used for system setting and it can be used only in privileged state.
3. _____ instructions are those that change the format or operate on the format of data.

9.10 Summary

1. Addressing modes are an aspect of the instruction set architecture in most central processing unit (CPU) designs.
2. An addressing mode specifies how to calculate the effective memory address of an operand by using information held in registers and/or constants contained within a machine instruction or elsewhere.

3. The term addressing modes refers to the way in which the operand of an instruction is specified.
4. Arithmetic instructions perform several basic operations such as addition, subtraction, division, multiplication etc.
5. There are two kinds of branch instructions: Unconditional jump instructions: upon their execution a jump to a new location from where the program continues execution is executed. Conditional jump instructions: a jump to a new program location is executed only if a specified condition is met. Otherwise, the program normally proceeds with the next instruction.
6. Data transfer instructions move the content of one register to another.
7. Logic instructions perform logic operations upon corresponding bits of two registers.
8. Similar to logic instructions, bit-oriented instructions perform logic operations. The difference is that these are performed upon single bits.

9.11 Model Questions

1. List out the various addressing techniques.
2. Discuss about different types of addressing modes.
3. List out the types in displacement addressing.
4. Explain in detail about different instruction types and instruction sequencing.
5. Explain the importance of different addressing modes in computer architecture with suitable example.
6. What is an instruction format? Explain different types of instruction formats in detail.
7. What is the difference between a direct and indirect address instruction? How many references to memory are needed for each type of instruction to bring an operand into a processor register?
8. Write a note on program control instructions.
9. Explain the various Instruction types based on the length.
10. What is a procedure? Explain.

11. Data can be categorized into how many forms?
12. What are the typical elements of a machine instruction?
13. What are the different categories of instructions?
14. Why are transfer of control instructions needed?
15. If an instruction contains four addresses, what might be the purpose of each address?
16. List and explain the important design issues for instruction set design.
17. What are the different types of operands may present in an instruction?
18. Briefly explain the following addressing modes- immediate addressing direct addressing, indirect addressing displacement addressing and relative addressing
19. What is indexed addressing and what is the advantage of auto indexing?
20. What are the advantages and disadvantages of using a variable-length instruction format?



Answers to Check your progress I

1. Immediate
2. Register
3. Register Indirect
4. Direct
5. Indirect
6. Displacement



Answers to Check your progress II

1. Data transfer
2. System
3. Conversion

CPU DESIGN

10.0 Learning Objectives

After completing this unit, the learner shall be able to:

- Know the operations or tasks that are performed by CPU;
 - Know the major components of the CPU;
 - Explain the various components of a system bus;
 - Know the categories of CPU registers;
 - Define processor status word;
 - Explain Instruction cycle and Instruction Cycle State Diagram;
-

10.1 Introduction to CPU

The operation or task that must perform by CPU are:

Fetch Instruction: The CPU reads an instruction from memory.

Interpret Instruction: The instruction is decoded to determine what action is required.

Fetch Data: The execution of an instruction may require reading data from memory or I/O module.

Process data: The execution of an instruction may require performing some arithmetic or logical operation on data.

Write data: The result of an execution may require writing data to memory or an I/O module.

To do these tasks, it should be clear that the CPU needs to store some data temporarily. It must remember the location of the last instruction so that it can know where to get the next instruction. It needs to store instructions and data temporarily while an instruction is being executed. In other words, the CPU needs a small internal memory. These storage locations are generally referred as registers. The major components of the CPU are an arithmetic and logic unit (ALU) and a control unit (CU). The ALU does the actual computation or processing of data. The CU controls the movement of data and instruction into and out of the CPU and controls the operation of the ALU.

The CPU is connected to the rest of the system through system bus. Through system bus, data or information gets transferred between the CPU and the other component of the system. The system bus may have three components:

Data Bus: Data bus is used to transfer the data between main memory and CPU.

Address Bus: Address bus is used to access a particular memory location by putting the address of the memory location.

Control Bus: Control bus is used to provide the different control signal generated by CPU to different part of the system. As for example, memory read is a signal generated by CPU to indicate that a memory read operation has to be performed. Through control bus this signal is transferred to memory module to indicate the required operation.

There are three basic components of CPU: register bank, ALU and Control Unit. There are several data movements between these units and for that an internal CPU bus is used. Internal CPU bus is needed to transfer data between the various registers and the ALU. The internal organization of CPU in more abstract level is shown in the Figure 5.1 and Figure 5.2.

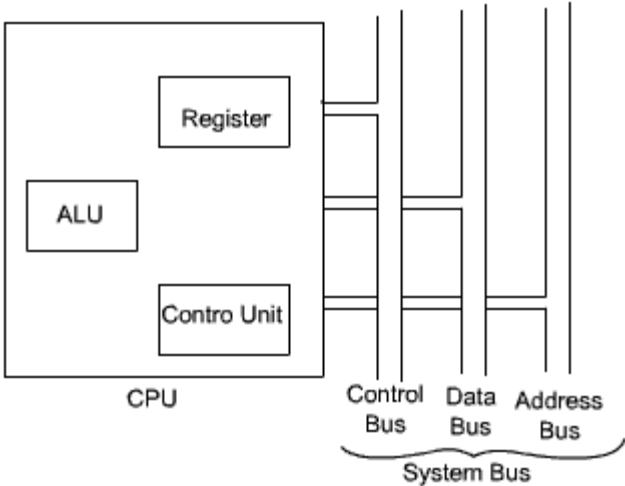

Figure 5.1: CPU with the system Bus

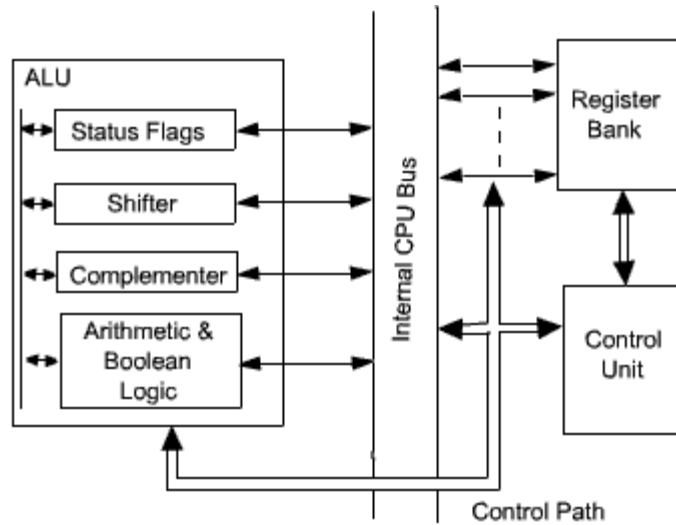

Figure 5.2: Internal Structure of the CPU

10.2 Register Organization

A computer system employs a memory hierarchy. At the highest level of hierarchy, memory is faster, smaller and more expensive. Within the CPU, there is a set of registers which can be treated as a memory in the highest level of hierarchy. The registers in the CPU can be categorized into two groups:

User-visible registers: These enables the machine - or assembly-language programmer to minimize main memory reference by optimizing use of registers.

Control and status registers: These are used by the control unit to control the operation of the CPU. Operating system programs may also use these in privileged mode to control the execution of program.

10.2.1 User-visible Registers

The user-visible registers can be categorized as follows:

- General Purpose Registers
- Data Registers
- Address Registers

- Condition Codes

General-purpose registers can be assigned to a variety of functions by the programmer. In some cases, general-purpose registers can be used for addressing functions (e.g., register indirect, displacement). In other cases, there is a partial or clean separation between data registers and address registers.

Data registers may be used to hold only data and cannot be employed in the calculation of an operand address.

Address registers may be somewhat general purpose, or they may be devoted to a particular addressing mode. Examples include the following:

- Segment pointer: In a machine with segment addressing, a segment register holds the address of the base of the segment. There may be multiple registers, one for the code segment and one for the data segment.
- Index registers: These are used for indexed addressing and may be autoindexed.
- Stack pointer: If there is user visible stack addressing, then typically the stack is in memory and there is a dedicated register that points to the top of the stack.

Condition Codes (also referred to as flags) are bits set by the CPU hardware as the result of the operations. For example, an arithmetic operation may produce a positive, negative, zero or overflow result. In addition to the result itself being stored in a register or memory, a condition code is also set. The code may be subsequently be tested as part of a condition branch operation. Condition code bits are collected into one or more registers.

10.3 CPU Register Organization

There are a variety of CPU registers that are employed to control the operation of the CPU. Most of these, on most machines, are not visible to the user. Different machines will have different register organizations and use different terminology. We will discuss here the most commonly used registers which are part of most of the machines.

Four registers are essential to instruction execution:

- Program Counter (PC): Contains the address of an instruction to be fetched. Typically, the PC is updated by the CPU after each instruction fetched so that it always points to the next instruction to be executed. A branch or skip instruction will also modify the contents of the PC.
- Instruction Register (IR): Contains the instruction most recently fetched. The fetched instruction is loaded into an IR, where the opcode and operand specifiers are analyzed.
- Memory Address Register (MAR): Contains the address of a location of main memory from where information has to be fetched or information has to be stored. Contents of MAR is directly connected to the address bus.
- Memory Buffer Register (MBR): Contains a word of data to be written to memory or the word most recently read. Contents of MBR is directly connected to the data bus. It is also known as Memory Data Register (MDR).

Apart from these specific registers, we may have some temporary registers which are not visible to the user. As such, there may be temporary buffering registers at the boundary to the ALU; these registers serve as input and output registers for the ALU and exchange data with the MBR and user visible registers.

10.3.1 Processor Status Word

All CPU designs include a register or set of registers, often known as the processor status word (PSW), that contains status information. The PSW typically contains condition codes plus other status information. Common fields or flags include the following:

- Sign: Contains the sign bit of the result of the last arithmetic operation.
- Zero: Set when the result is zero.
- Carry: Set if an operation resulted in a carry (addition) into or borrow (subtraction) out of a high order bit.
- Equal: Set if a logical compare result is equal.
- Overflow: Used to indicate arithmetic overflow.
- Interrupt enable/disable: Used to enable or disable interrupts.
- Supervisor: Indicate whether the CPU is executing in supervisor or user mode. Certain privileged instructions can be executed only in supervisor mode, and certain areas of memory can be accessed only in supervisor mode.

Apart from these, a number of other registers related to status and control might be found in a particular CPU design. In addition to the PSW, there may be a pointer to a block of memory containing additional status information (e.g. process control blocks).

10.4 Concept of Program Execution

The instructions constituting a program to be executed by a computer are loaded in sequential locations in its main memory. To execute this program, the CPU fetches one instruction at a time and performs the functions specified. Instructions are fetched from successive memory locations until the execution of a branch or a jump instruction.

The CPU keeps track of the address of the memory location where the next instruction is located through the use of a dedicated CPU register, referred to as the program counter (PC). After fetching an instruction, the contents of the PC are updated to point at the next instruction in sequence. For simplicity, let us assume that each instruction occupies one memory word. Therefore, execution of one instruction requires the following three steps to be performed by the CPU:

1. Fetch the contents of the memory location pointed at by the PC. The contents of this location are interpreted as an instruction to be executed. Hence, they are stored in the instruction register (IR). Symbolically this can be written as:

$$IR = [[PC]]$$

2. Increment the contents of the PC by 1.

$$PC = [PC] + 1$$

3. Carry out the actions specified by the instruction stored in the IR.

The first two steps are usually referred to as the fetch phase and the step 3 is known as the execution phase. Fetch cycle basically involves read the next instruction from the memory into the CPU and along with that update the contents of the program counter. In the

execution phase, it interprets the opcode and perform the indicated operation. The instruction fetch and execution phase together known as instruction cycle. The basic instruction cycle is shown in the Figure 5.3

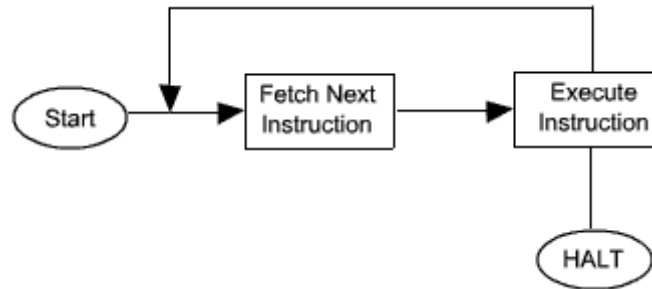

Figure 5.3: Basic Instruction cycle

In cases, where an instruction occupies more than one word, step 1 and step 2 can be repeated as many times as necessary to fetch the complete instruction. In these cases, the execution of a instruction may involve one or more operands in memory, each of which requires a memory access. Further, if indirect addressing is used, then additional memory access is required.

The fetched instruction is loaded into the instruction register. The instruction contains bits that specify the action to be performed by the processor. The processor interprets the instruction and performs the required action. In general, the actions fall into four categories:

- Processor-memory: Data may be transferred from processor to memory or from memory to processor.
- Processor-I/O: Data may be transferred to or from a peripheral device by transferring between the processor and an I/O module.
- Data processing: The processor may perform some arithmetic or logic operation on data.
- Control: An instruction may specify that the sequence of execution be altered.

The main line of activity consists of alternating instruction fetch and instruction execution activities. After an instruction is fetched, it is examined to determine if any indirect addressing is involved. If so, the required operands are fetched using indirect addressing.

The execution cycle of a particular instruction may involve more than one reference to memory. Also, instead of memory references, an instruction may specify an I/O operation. With these additional considerations the basic instruction cycle can be expanded with more details view in the Figure 5.4. The figure is in the form of a state diagram.

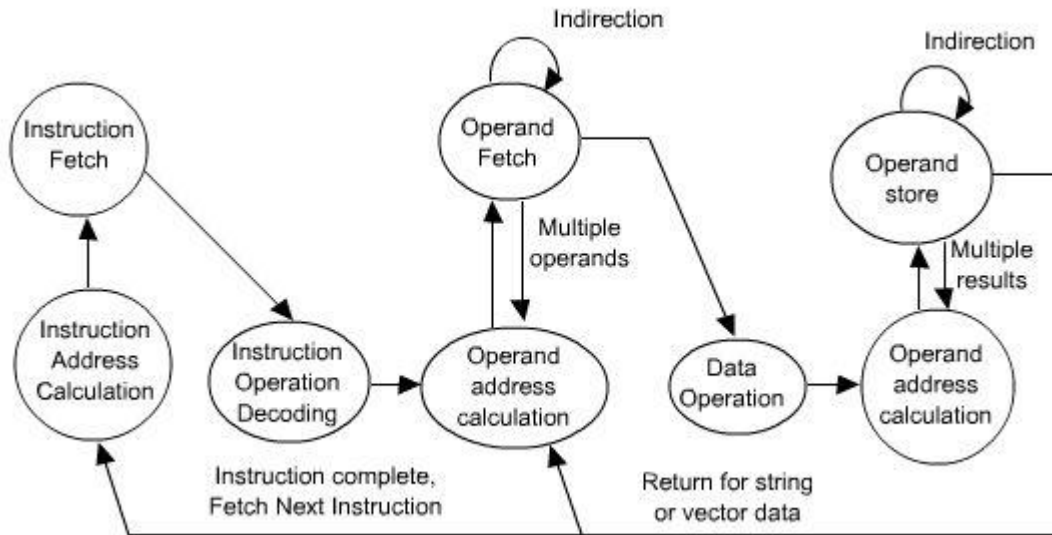

Figure 5.4: Instruction cycle state diagram.



Check your progress I

1. The full form of CPU is _____.
2. ALU stands for _____.
3. _____ holds the address of the next instruction to be executed.
4. An instruction cycle consists of two phase, _____ cycle and _____ cycle.
5. _____ is used to provide the different control signal generated by CPU to different part of the system.
6. _____ may be used to hold only data and cannot be employed in the calculation of an operand address.
7. _____ are used for indexed addressing and may be autoindexed.

10.5 Processor Organization

There are several components inside a CPU, namely, ALU, control unit, general purpose register, Instruction registers etc. Now we will see how these components are organized inside CPU. There are several ways to place these components and interconnect them. One such organization is shown in the Figure 5.6.

In this case, the arithmetic and logic unit (ALU), and all CPU registers are connected via a single common bus. This bus is internal to CPU and this internal bus is used to transfer the information between different components of the CPU. This organization is termed as single bus organization, since only one internal bus is used for transferring of information between different components of CPU. We have external bus or buses to CPU also to connect the CPU with the memory module and I/O devices. The external memory bus is also shown in the Figure 5.6 connected to the CPU via the memory data and address register MDR and MAR.

The number and function of registers R_0 to $R_{(n-1)}$ vary considerably from one machine to another. They may be given for general-purpose for the use of the programmer. Alternatively, some of them may be dedicated as special-purpose registers, such as index register or stack pointers. In this organization, two registers, namely Y and Z are used which are transparent to the user. Programmer cannot directly access these two registers. These are used as input and output buffer to the ALU which will be used in ALU operations. They will be used by CPU as temporary storage for some instructions.

For the execution of an instruction, we need to perform an instruction cycle. An instruction cycle consists of two phases,

- Fetch cycle and
- Execution cycle.

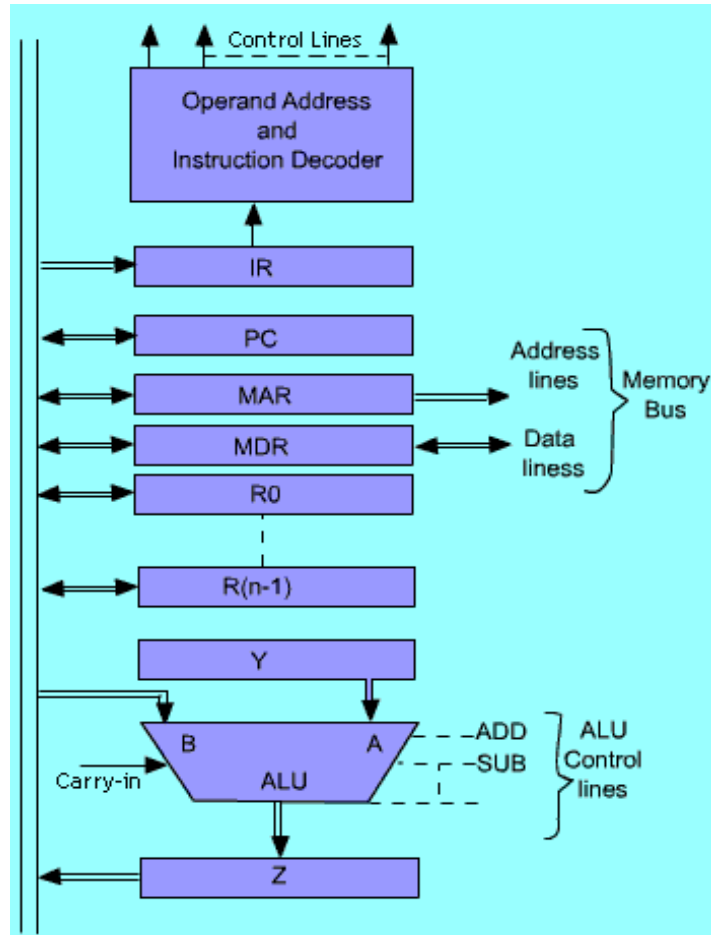

Figure 5.6: Single bus organization of the data path inside the CPU

Most of the operation of a CPU can be carried out by performing one or more of the following functions in some prespecified sequence:

1. Fetch the contents of a given memory location and load them into a CPU register.
2. Store a word of data from a CPU register into a given memory location.
3. Transfer a word of data from one CPU register to another or to the ALU.
4. Perform an arithmetic or logic operation, and store the result in a CPU register.

Now we will examine the way in which each of the above functions is implemented in a computer. Fetching a Word from Memory:

Information is stored in memory location identified by their address. To fetch a word from memory, the CPU has to specify the address of the memory location where this

information is stored and request a Read operation. The information may include both, the data for an operation or the instruction of a program which is available in main memory.

To perform a memory fetch operation, we need to complete the following tasks:

The CPU transfers the address of the required memory location to the Memory Address Register (MAR).

The MAR is connected to the memory address line of the memory bus, hence the address of the required word is transferred to the main memory.

Next, CPU uses the control lines of the memory bus to indicate that a Read operation is initiated. After issuing this request, the CPU waits until it receives an answer from the memory, indicating that the requested operation has been completed.

This is accomplished by another control signal of memory bus known as Memory-Function-Complete (MFC). The memory set this signal to 1 to indicate that the contents of the specified memory location are available in memory data bus.

As an example, assume that the address of the memory location to be accessed is kept in register R2 and that the memory contents to be loaded into register R1. This is done by the following sequence of operations:

1. MAR [R2]
2. Read
3. Wait for MFC signal
4. R1 [MDR]

The time required for step 3 depends on the speed of the memory unit. In general, the time required to access a word from the memory is longer than the time required to perform any operation within the CPU.

The scheme that is used here to transfer data from one device (memory) to another device (CPU) is referred to as an asynchronous transfer.

This asynchronous transfer enables transfer of data between two independent devices that have different speeds of operation. The data transfer is synchronized with the help of some control signals. In this example, Read request and MFC signal are doing the synchronization task.

An alternative scheme is synchronous transfer. In this case all the devices are controlled by a common clock pulse (continuously running clock of a fixed frequency). These pulses provide common timing signal to the CPU and the main memory. A memory operation is completed during every clock period. Though the synchronous data transfer scheme leads to a simpler implementation, it is difficult to accommodate devices with widely varying speed. In such cases, the duration of the clock pulse will be synchronized to the slowest device. It reduces the speed of all the devices to the slowest one.

As soon as MFC signal is set to 1, the information available in the data bus is loaded into the Memory Data Register (MDR) and this is available for use inside the CPU.

10.6 Storing a word into memory

The procedure of writing a word into memory location is similar to that for reading one from memory. The only difference is that the data word to be written is first loaded into the MDR, the write command is issued.

As an example, assumes that the data word to be stored in the memory is in register R1 and that the memory address is in register R2. The memory write operation requires the following sequence:

1. MAR [R2]
2. MDR [R1]
3. Write
4. Wait for MFC

In this case step 1 and step 2 are independent and so they can be carried out in any order. In fact, step 1 and 2 can be carried out simultaneously, if this is allowed by the architecture, that is, if these two data transfers (memory address and data) do not use the same data path. In case of both memory read and memory write operation, the total time duration depends on wait for the MFC signal, which depends on the speed of the memory module.

There is a scope to improve the performance of the CPU, if CPU is allowed to perform some other operation while waiting for MFC signal. During the period, CPU can perform some other instructions which do not require the use of MAR and MDR.

10.7 Register Transfer Operation

Register transfer operations enable data transfer between various blocks connected to the common bus of CPU. We have several registers inside CPU and it is needed to transfer information from one register another. As for example during memory write operation data from appropriate register must be moved to MDR.

Since the input output lines of all the register are connected to the common internal bus, we need appropriate input output gating. The input and output gates for register R_i are controlled by the signal R_i in and R_i out respectively. Thus, when R_i in set to 1 the data available in the common bus is loaded into R_i . Similarly, when, R_i out is set to 1, the contents of the register R_i are placed on the bus. To transfer data from one register to other register, we need to generate the appropriate register gating signal

For example, to transfer the contents of register R_1 to register R_2 , the following actions are needed:

- Enable the output gate of register R_1 by setting R_{1out} to 1.

-- This places the contents of R_1 on the CPU bus.

- Enable the input gate of register R2 by setting R2 in to 1.

-- This loads data from the CPU bus into the register R2.

10.7.1 Performing the arithmetic or logic operation

Generally, ALU is used inside CPU to perform arithmetic and logic operation. ALU is a combinational logic circuit which does not have any internal storage. Therefore, to perform any arithmetic or logic operation (say binary operation) both the input should be made available at the two inputs of the ALU simultaneously. Once both the inputs are available then appropriate signal is generated to perform the required operation.

We may have to use temporary storage (register) to carry out the operation in ALU. The sequence of operations that have to be carried out to perform one ALU operation depends on the organization of the CPU. Consider an organization in which one of the operands of ALU is stored in some temporary register Y and other operand is directly taken from CPU internal bus. The result of the ALU operation is stored in another temporary register Z. This organization is shown in the Figure 5.7.

Therefore, the sequence of operations to add the contents of register R1 to register R2 and store the result in register R3 should be as follows:

1. R1out, Yin
2. R2out, Add, Zin
3. Zout, R3in

In step 2 of this sequence, the contents of register R2 are gated to the bus, hence to input – B of the ALU which is directly connected to the bus. The contents of register Y are always available at input A of ALU. The function performed by the ALU depends on the signal applied to the ALU control lines. In this example, the Add control line of ALU is set to 1, which indicates the addition operation and the output of ALU is the sum of the two numbers at input A and B. The sum is loaded into register Z, since the input gate is enabled (Zin). In step 3, the contents of register Z are transferred to the destination register R3.

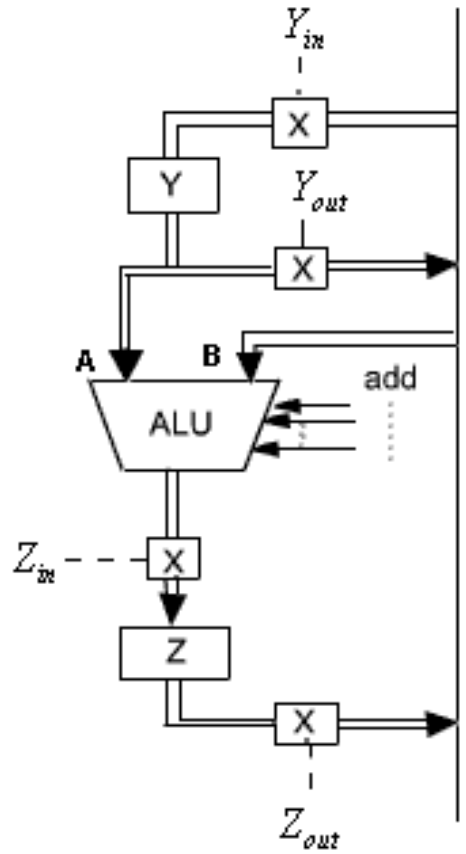

Figure 5.7: Organization for Arithmetic & Logic Operation

10.8 Multiple Bus Organization

Till now we have considered only one internal bus of CPU. The single-bus organization, which is only one of the possibilities for interconnecting different building blocks of CPU.

An alternative structure is the two-bus structure, where two different internal buses are used in CPU. All register outputs are connected to bus A, add all registered inputs are connected to bus B.

There is a special arrangement to transfer the data from one bus to the other bus. The buses are connected through the bus tie G. When this tie is enabled data on bus A is transfer to bus B. When G is disabled, the two buses are electrically isolated.

Since two buses are used here the temporary register Z is not required here which is used in single bus organization to store the result of ALU. Now result can be directly transferred to bus B, since one of the inputs is in bus A. With the bus tie disabled, the result can directly be transferred to destination register. A simple two bus structure is shown in the Figure 5.8.

For example, for the operation, $[R3] \leftarrow [R1] + [R2]$ can now be performed as

- a. $R1_{out}, G_{enable}, Y_{in}$
- b. $R2_{out}, Add, ALU_{out}, R3_{in}$

In this case source register R2 and destination register R3 has to be different, because the two operations R2in and R2out cannot be performed together. If the registers are made of simple latches then only, we have the restriction.

We may have another CPU organization, where three internal CPU buses are used. In this organization each bus connected to only one output and number of inputs. The elimination of the need for connecting more than one output to the same bus leads to faster bus transfer and simple control. A simple three-bus organization is shown in the figure 5.9.

A multiplexer is provided at the input to each of the two working registers A and B, which allow them to be loaded from either the input data bus or the register data bus. In the diagram, a possible interconnection of three-bus organization is presented, there may be different interconnections possible.

In this three-bus organization, we are keeping two input data buses instead of one that is used in two bus organization. Two separate input data buses are present – one is for external data transfer, i.e. retrieving from memory and the second one is for internal data transfer that is transferring data from general purpose register to other building block inside the CPU.

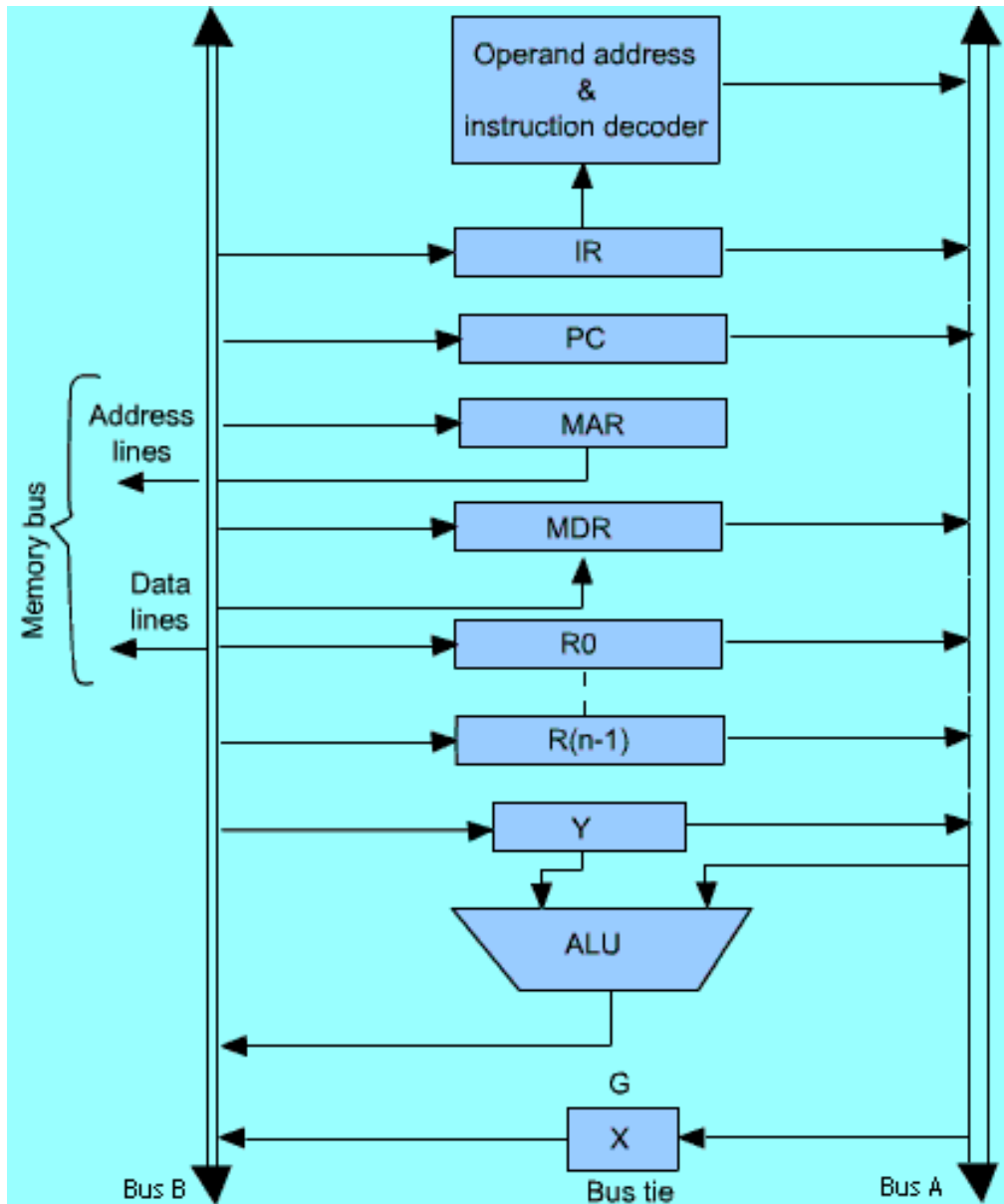

Figure 5.8: Two bus structure

Like two bus organization, we can use bus tie to connect the input bus and output bus. When the bus tie is enable, the information that is present in input bus is directly transferred to output bus. We may use one bus tie G1 between input data bus and ALU output bus and another bus tie G2 between register data bus and ALU output data bus.

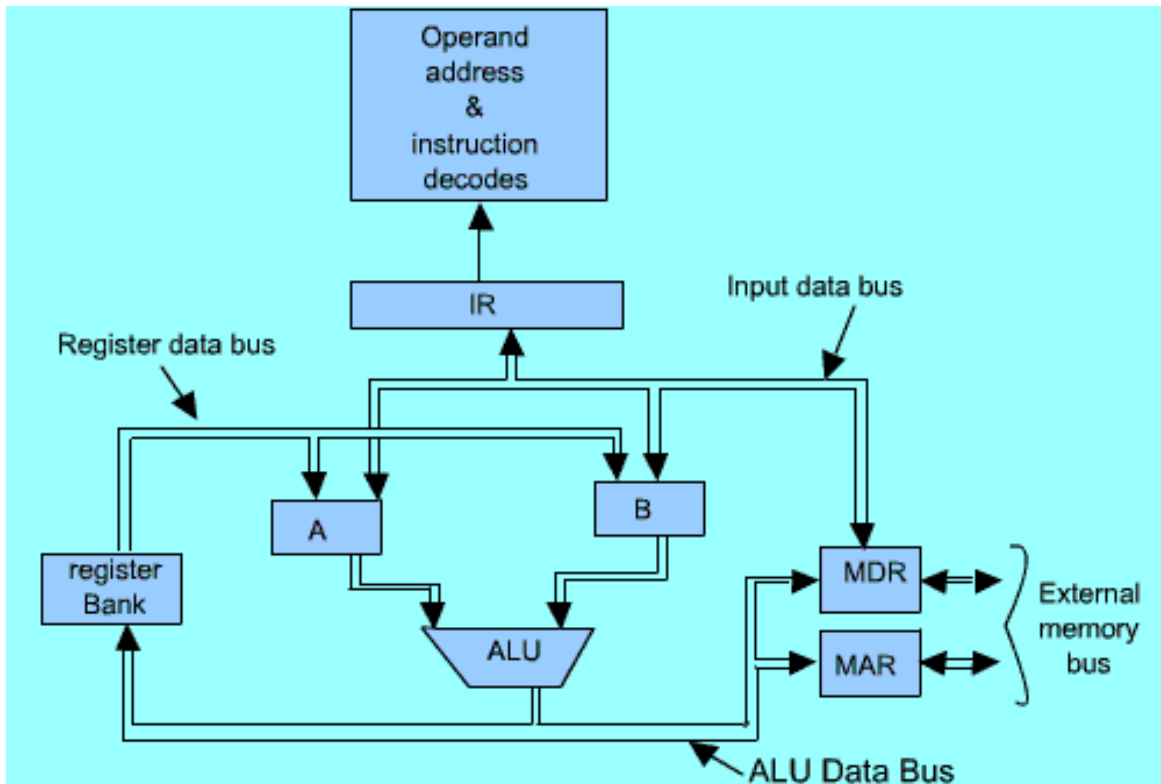

Figure 5.9: Three Bus structure

10.9 Execution of a Complete Instructions

We have discussed about four different types of basic operations:

- Fetch information from memory to CPU
- Store information to CPU register to memory
- Transfer of data between CPU registers.
- Perform arithmetic or logic operation and store the result in CPU registers.

To execute a complete instruction, we need to take help of these basic operations and we need to execute these operations in some particular order. As for example, consider the instruction: "Add contents of memory location NUM to the contents of register R1 and store the result in register R1." For simplicity, assume that the address NUM is given explicitly in the address field of the instruction. That is, in this instruction, direct addressing mode is used. Execution of this instruction requires the following action:

1. Fetch instruction
2. Fetch first operand (Contents of memory location pointed at by the address field of the instruction)
3. Perform addition
4. Load the result into R1.

Following sequence of control steps are required to implement the above operation for the single-bus architecture that we have discussed in earlier section.

Steps	Actions
1.	PC_{out} , MAR_{in} , Read, Clear Y, Set carry -in to ALU, Add, Z_{in}
2.	Z_{out} , PC_{in} , Wait For MFC
3.	MDR_{out} , Ir_{in}
4.	Address-field- of- IR_{out} , MAR_{in} , Read
5.	$R1_{out}$, Y_{in} , Wait for MFC
6.	MDR_{out} , Add, Z_{in}
7.	Z_{out} , $R1_{in}$
8.	END

Instructions execution proceeds as follows:

In Step1: The instruction fetch operation is initiated by loading the contents of the PC into the MAR and sending a read request to memory. To perform this task first of all the contents of PC have to be brought to internal bus and then it is loaded to MAR. To perform this task control circuit has to generate the PC_{out} signal and MAR in signal. After issuing the read signal, CPU has to wait for some time to get the MFC signal. During that time PC is updated by 1 through the use of the ALU. This is accomplished by setting one of the inputs to the ALU (Register Y) to 0 and the other input is available in bus which is current value of PC. At the same time, the carry-in to the ALU is set to 1 and an add operation is specified.

In Step 2: The updated value is moved from register Z back into the PC. Step 2 is initiated immediately after issuing the memory Read request without waiting for completion of memory function. This is possible, because step 2 does not use the memory bus and its execution does not depend on the memory read operation.

In Step 3: Step3 has been delayed until the MFC is received. Once MFC is received, the word fetched from the memory is transferred to IR (Instruction Register), Because it is an instruction. Step 1 through 3 constitute the instruction fetch phase of the control sequence. The instruction fetch portion is same for all instructions. Next step onwards, instruction execution phase takes place.

As soon as the IR is loaded with instruction, the instruction decoding circuits interprets its contents. This enables the control circuitry to choose the appropriate signals for the remainder of the control sequence, step 4 to 8, which we referred to as the execution phase. To design the control sequence of execution phase, it is needed to have the knowledge of the internal structure and instruction format of the PU. Secondly, the length of instruction phase is different for different instruction.

In this example, we have assumed the following instruction format:

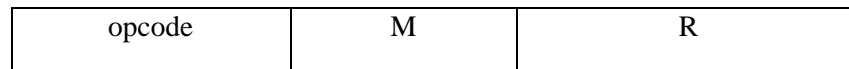

i.e., opcode: Operation Code

M: Memory address for source

R: Register address for source/destination

In Step 5: The destination field of IR, which contains the address of the register R1, is used to transfer the contents of register R1 to register Y and wait for Memory function Complete. When the read operation is completed, the memory operand is available in MDR.

In Step 6: The result of addition operation is performed in this step.

In Step 7: The result of addition operation is transferred from temporary register Z to the destination register R1 in this step.

In step 8: It indicates the end of the execution of the instruction by generating End signal. This indicates completion of execution of the current instruction and causes a new fetch cycle to be started by going back to step 1.

10.10 Branching

With the help of branching instruction, the control of the execution of the program is transferred from one particular position to some other position, due to which the sequence flow of control is broken. Branching is accomplished by replacing the current contents of the PC by the branch address, that is, the address of the instruction to which branching is required. Consider a branch instruction in which branch address is obtained by adding an offset X, which is given in the address field of the branch instruction, to the current value of PC. Consider the following unconditional branch instruction

JUMP X

i.e., the format is

opcode	offset of jump
--------	----------------

The control sequence that enables execution of an unconditional branch instruction using the single - bus organization is as follows:

Execution starts as usual with the fetch phase, ending with the instruction being loaded into the IR in step 3. To execute the branch instruction, the execution phase starts in step 4.

In Step 4: The contents of the PC are transferred to register Y.

In Step 5: The offset X of the instruction is gated to the bus and the addition operation is performed.

In Step 6: The result of the addition, which represents the branch address is loaded into the PC.

In Step 7: It generates the End signal to indicate the end of execution of the current instruction.

Steps	Actions
1.	PC _{out} , MAR _{in} , Read, Clear Y, Set Carry-in to ALU, Add ,Z _{in}
2.	Z _{out} , PC _{in} , Wait for MFC
3.	MDR _{out} , IR _{in}
4.	PC _{out} , Y _{in}
5.	Address field-of IR _{out} , Add, Z _{in}
6.	Z _{out} , PC _{in}
7.	End

Consider now the conditional branch instruction instead of unconditional branch. In this case, we need to check the status of the condition codes, between step 3 and 4. i.e., before adding the offset value to the PC contents.

For example, if the instruction decoding circuitry interprets the contents of the IR as a branch on Negative (BRN) instruction, the control unit proceeds as follows: First the condition code register is checked. If bit N (negative) is equal to 1 , the control unit proceeds with step 4 through step 7 of control sequence of unconditional branch instruction.

If, on the other hand , N is equal to 0, and End signal is issued .

This in effect, terminates execution of the branch instruction and causes the instruction immediately following in the branch instruction to be fetched when a new fetch operation is performed.

Therefore, the control sequence for the conditional branch instruction BRN can be obtained from the control sequence of an unconditional branch instruction by replacing the step 4 by

4. If \bar{N} then End

If N then $PC_{out, yin}$

Most commonly need conditional branch instructions are

- BNZ: Branch on not Zero
- BZ: Branch on positive
- BP: Branch on Positive
- BNP: Branch on not Positive
- BO: Branch on overflow



Answers to Check your progress II

1. The processing required for the execution a single instruction is known as _____.
2. _____ is accomplished by replacing the current contents of the PC by the branch address, that is, the address of the instruction to which branching is required.
3. The Bus which is connecting the major three components of a computer (CPU, Memory and Input/Output devices) is known as _____.

10.11 Summary

1. The major components of the CPU are an arithmetic and logic unit (ALU) and a control unit (CU).
2. The ALU does the actual computation or processing of data. The CU controls the movement of data and instruction into and out of the CPU and controls the operation of the ALU.
3. There are three basic components of CPU: register bank, ALU and Control Unit.
4. A computer system employs a memory hierarchy. At the highest level of hierarchy, memory is faster, smaller and more expensive.
5. The registers in the CPU can be categorized into two groups, User-visible registers and Control and status registers.

6. General-purpose registers can be assigned to a variety of functions by the programmer. In some cases, general- purpose registers can be used for addressing functions.
7. Data registers may be used to hold only data and cannot be employed in the calculation of an operand address.
8. Address registers may be somewhat general purpose, or they may be devoted to a particular addressing mode.
9. Condition Codes (also referred to as flags) are bits set by the CPU hardware as the result of the operations.
10. All CPU designs include a register or set of registers, often known as the processor status word (PSW), that contains status information.
11. The PSW typically contains condition codes plus other status information.
12. The instructions constituting a program to be executed by a computer are loaded in sequential locations in its main memory.
13. To execute this program, the CPU fetches one instruction at a time and performs the functions specified. Instructions are fetched from successive memory locations until the execution of a branch or a jump instruction.
14. The CPU keeps track of the address of the memory location where the next instruction is located through the use of a dedicated CPU register, referred to as the program counter (PC).
15. This bus is internal to CPU and this internal bus is used to transfer the information between different components of the CPU.
16. Bus width means the number of lines available in the Bus.
17. An instruction cycle consists of two phase, Fetch cycle and Execution cycle.
18. Register transfer operations enable data transfer between various blocks connected to the common bus of CPU.

10.12 Model Questions

1. What are the operations or tasks that must be performed by CPU?
2. What is a system bus? Why it is required? What are the various components of a system bus?

3. Explain the internal organization of a CPU with the help of a diagram.
4. Explain the concept of memory hierarchy.
5. What are General Purpose CPU registers?
6. Discuss the most commonly used registers which are part of most of the machines.
7. What is the Processor Status Word (PSW)? Discuss common fields or flags of PSW.
8. What is instruction cycle? Explain with the help of a diagram.
9. Describe Instruction cycle state diagram.
10. Explain the working of 16-bit common bus.
11. Explain the detail the steps involved in the execution of a complete Instructions.
12. Explain the use of the following registers-
 - a. Program counter
 - b. Instruction register
 - c. Memory address register
 - d. Memory buffer register



Answers to Check your progress I

1. Central Processing Unit
2. Arithmetic Logic Unit
3. Program Counter
4. Fetch, Execution
5. Control bus
6. Data registers
7. Index registers



Answers to Check your progress II

1. Instruction Cycle
2. Branching
3. System Bus

DESIGN OF CONTROL UNIT

11.0 Learning Objectives

After the completion of this unit, the learner shall be able to:

- Differentiate between hardwired and the microprogrammed control unit;
- Know the internal architecture of the hardwired control unit;
- Explain Programmable Logic Array;
- Know the internal organization of microprogrammed control unit;
- Explain control word;
- Explain microprogram sequencing;
- Know the concerns that are involved in the design of a microinstruction sequencing technique;

11.1 Design of Control Unit

To execute an instruction, the control unit of the CPU must generate the required control signal in the proper sequence. As for example, during the fetch phase, CPU has to generate PC_{out} signal along with other required signal in the first clock pulse. In the second clock pulse CPU has to generate PC_{in} signal along with other required signals. So, during fetch phase, the proper sequence for generating the signal to retrieve from and store to PC is PC_{out} and PC_{in} .

To generate the control signal in proper sequence, a wide variety of techniques exist. Most of these techniques, however, fall into one of the two categories,

- Hardwired Control
- Microprogrammed Control.

11.2 Hardwired Control

In this hardwired control techniques, the control signals are generated by means of hardwired circuit. The main objective of control unit is to generate the control signal in proper sequence.

Consider the sequence of control signal required to execute the ADD instruction that is explained in previous lecture. It is obvious that eight non-overlapping time slots are required for proper execution of the instruction represented by this sequence. Each time slot must be at least long enough for the function specified in the corresponding step to be completed. Since, the control unit is implemented by hardware device and every device is having a propagation delay, due to which it requires some time to get the stable output signal at the output port after giving the input signal. So, to find out the time slot is a complicated design task.

For the moment, for simplicity, let us assume that all slots are equal in time duration. Therefore, the required controller may be implemented based upon the use of a counter driven by a clock. Each state, or count, of this counter corresponds to one of the steps of the control sequence of the instructions of the CPU.

In the previous lecture, we have mentioned control sequence for execution of two instructions only (one is for add and other one is for branch). Like that we need to design the control sequence of all the instructions.

By looking into the design of the CPU, we may say that there are various instruction for add operation. As for example,

ADD NUM R1 Add the contents of memory location specified by NUM to the contents of register R1.

$$R_1 \leftarrow R_1 + [NUM]$$

ADD R2 R1 Add the contents of register R2 to the contents of register R1.

$$R_1 \leftarrow R_1 + R_2$$

The control sequence for execution of these two ADD instructions are different. Of course, the fetch phase of all the instructions remain same.

It is clear that control signals depend on the instruction, i.e., the contents of the instruction register. It is also observed that execution of some of the instructions depend on the contents of condition code or status flag register, where the control sequence depends in conditional branch instruction.

Hence, the required control signals are uniquely determined by the following information:

- Contents of the control counter.
- Contents of the instruction register.
- Contents of the condition code and other status flags.

The external inputs represent the state of the CPU and various control lines connected to it, such as MFC status signal. The condition codes/ status flags indicate the state of the CPU. These includes the status flags like carry, overflow, zero, etc.

11.2.1 Control Unit Organization

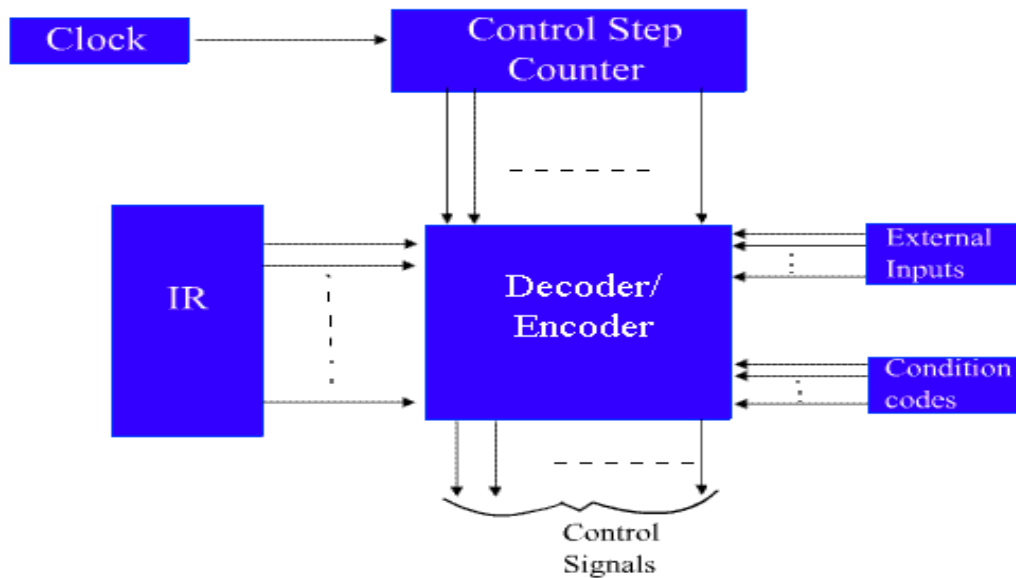

Figure 5.10: Organization of control unit.

The structure of control unit can be represented in a simplified view by putting it in block diagram. The detailed hardware involved may be explored step by step. The simplified view of the control unit is given in the Figure 5.10.

The decoder/encoder block is simply a combinational circuit that generates the required control outputs depending on the state of all its input.

The decoder part of decoder/encoder part provide a separate signal line for each control step, or time slot in the control sequence. Similarly, the output of the instructor decoder consists of a separate line for each machine instruction loaded in the IR, one of the output line INS_1 to INS_m is set to 1 and all other lines are set to 0.

The detailed view of the control unit organization is shown in the Figure 5.11.

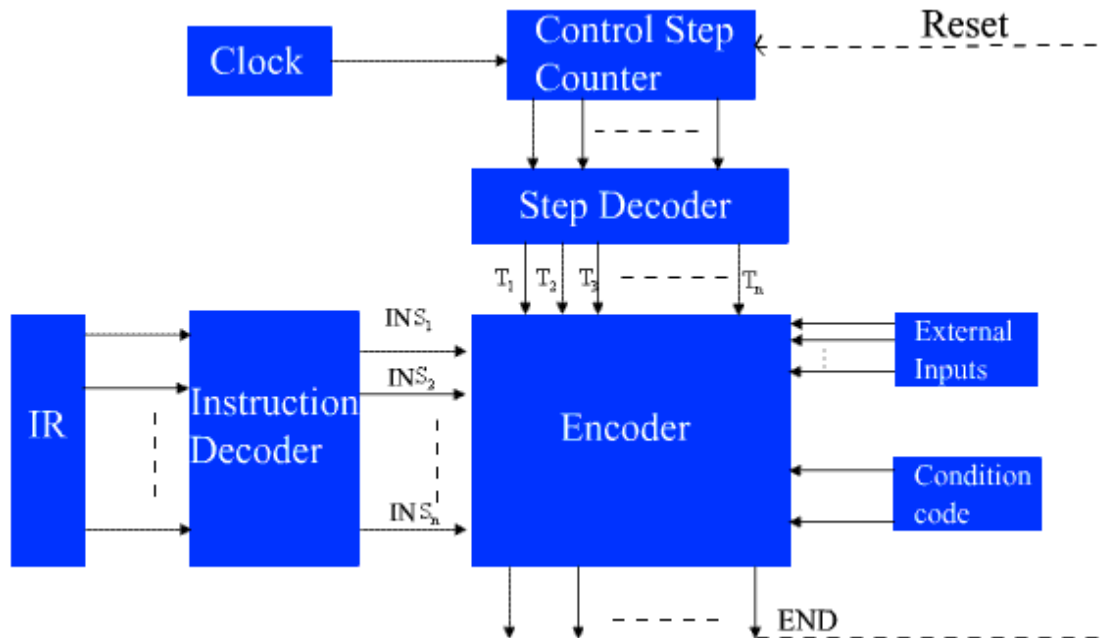

Figure 5.11: Detailed view of Control Unit organization

All input signals to the encoder block should be combined to generate the individual control signals.

In the previous section, we have mentioned the control sequence of the instruction,

"Add contents of memory location address in memory direct made to register R1 (ADD_MD)",

"Control sequence for an unconditional branch instruction (BR)",

Also, we have mentioned about Branch on negative (BRN).

Consider those three CPU instruction ADD_MD, BR, BRN.

It is required to generate many control signals by the control unit. These are basically coming out from the encoder circuit of the control signal generator. The control signals are: PC_{in}, PC_{out}, Z_{in}, Z_{out}, MAR_{in}, ADD, END, etc.

By looking into the above three instructions, we can write the logic function for Z_{in} as :

$$Z_{in} = T_1 + T_6 \cdot \text{ADD_MD} + T_5 \cdot \text{BR} + T_5 \cdot \text{BRN} + \dots$$

For all instructions, in time step1 we need the control signal Z_{in} to enable the input to register Z_{in} time cycle T₆ of ADD_MD instruction, in time cycle T₅ of BR instruction and so on.

Similarly, the Boolean logic function for ADD signal is

$$\text{ADD} = T_1 + T_6 \cdot \text{ADD_MD} + T_5 \cdot \text{BR} + \dots$$

These logic functions can be implemented by a two level combinational circuit of AND and OR gates.

Similarly, the END control signal is generated by the logic function:

$$\text{END} = T_8 \cdot \text{ADD_MD} + T_7 \cdot \text{BR} + (T_7 \cdot N + T_4 \cdot \bar{N}) \cdot \text{BRN} + \dots$$

This END signal indicates the end of the execution of an instruction, so this END signal can be used to start a new instruction fetch cycle by resetting the control step counter to its starting value.

The circuit diagram (Partial) for generating Zin and END signal is shown in the Figure 5.12 and Figure 5.13 respectively.

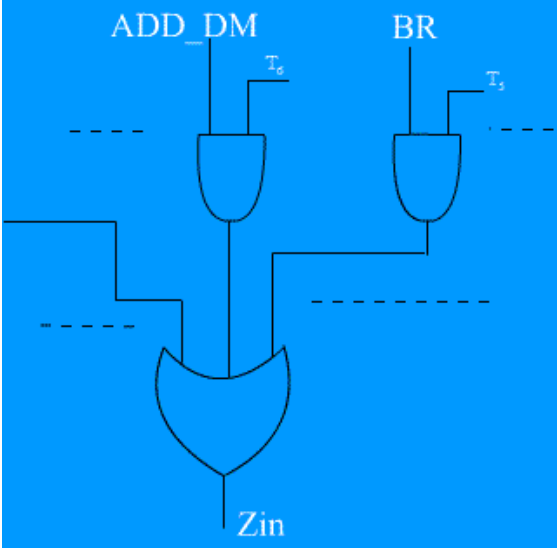

Figure 5.12: Generation of Zin Control Signal

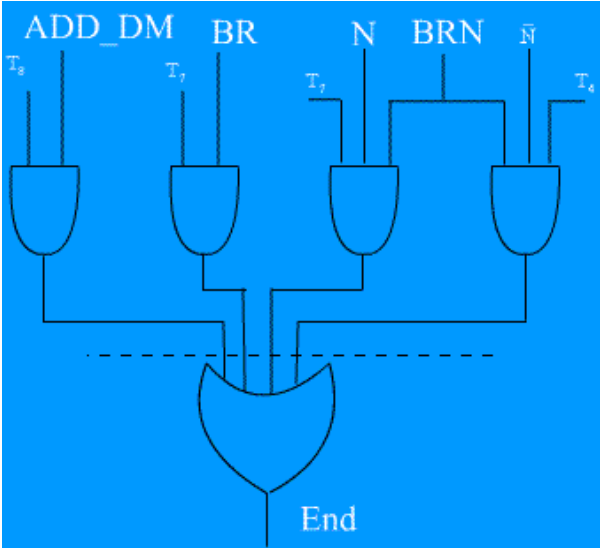

Figure 5.13: Generation of the END Control Signal

The signal ADD_MD, BR, BRN, etc. are coming from instruction decoder circuits which depends on the contents of IR.

The signal T₁, T₂, T₃ etc are coming out from step decoder depends on control step counter. The signal N (Negative) is coming from condition code register.

When wait for MFC (WMFC) signal is generated, then CPU does not do any works and it waits for an MFC signal from memory unit. In this case, the desired effect is to delay the initiation of the next control step until the MFC signal is received from the main memory. This can be incorporated by inhibiting the advancement of the control step counter for the required period.

Let us assume that the control step counter is controlled by a signal called RUN. By looking at the control sequence of all the instructions, the WMFC signal is generated as:

$$WMFC = T_2 + T_5 \cdot ADD_MD + \dots$$

The RUN signal is generated with the help of WMFC signal and MFC signal. The arrangement is shown in the Figure 5.14.

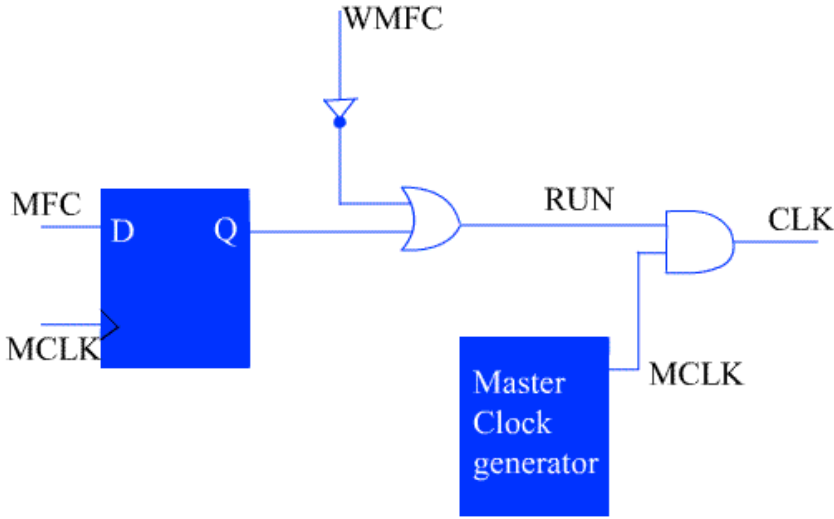

Figure 5.14: Generation of RUN signal

The MFC signal is generated by the main memory whose operation is independent of CPU clock. Hence MFC is an asynchronous signal that may arrive at any time relative to the CPU clock. It is possible to synchronized with CPU clock with the help of a D flip-flop.

When WMFC signal is high, then RUN signal is low. This run signal is used with the master clock pulse through an AND gate. When RUN is low, then the CLK signal remains low, and it does not allow to progress the control step counter.

When the MFC signal is received, the run signal becomes high and the CLK signal becomes same with the MCLK signal and due to which the control step counter progresses. Therefore, in the next control step, the WMFC signal goes low and control unit operates normally till the next memory access signal is generated.

The timing diagram for an instruction fetch operation is shown in the Figure 5.15.

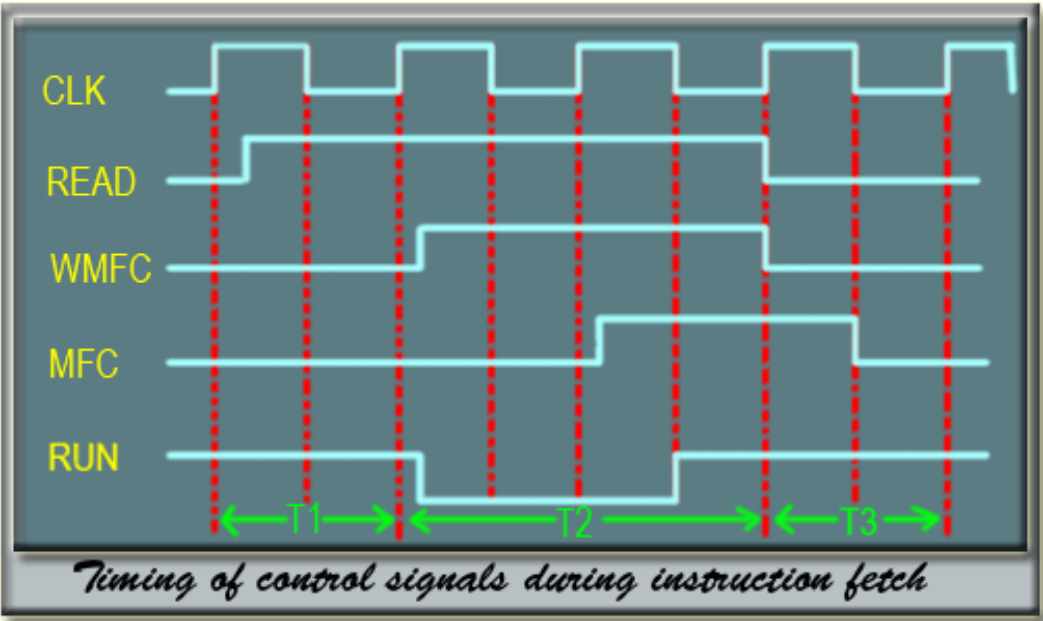

Figure 5.15: Timing of control signals during instruction fetch

11.3 Programmable Logic Array

In this discussion, we have presented a simplified view of the way in which the sequence of control signals needed to fetch and execute instructions may be generated.

It is observed from the discussion that as the number of instruction increases the number of required control signals will also increase.

In VLSI technology, structure that involve regular interconnection patterns are much easier to implement than the random connections.

One such regular structure is PLA (programmable logic array). PLAs are nothing but the arrays of AND gates followed by array of OR gates. If the control signals are expressed as sum of product form then with the help of PLA it can be implemented.

The PLA implementation of control unit is shown in the Figure 5.16.

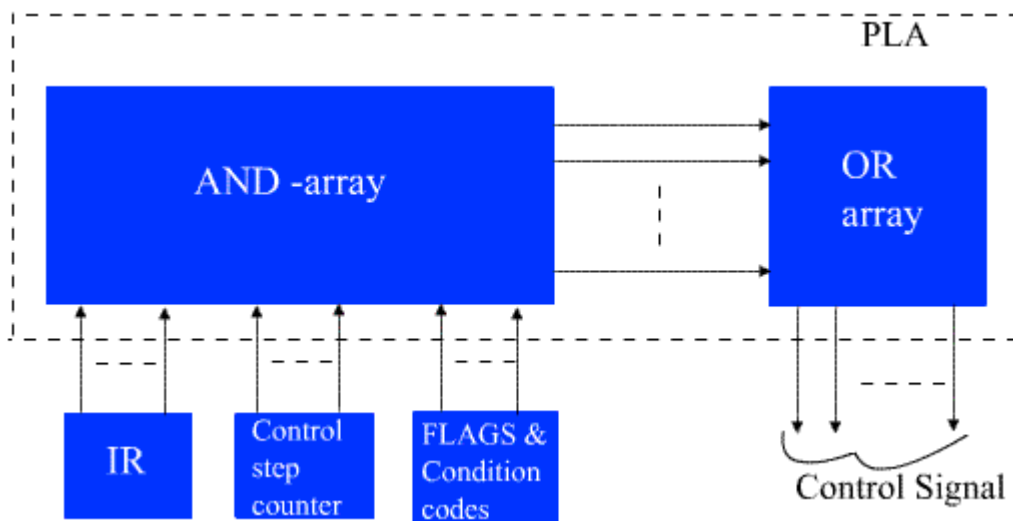

Figure 5.16: Instruction cycle state diagram with interrupt.



Check your progress I

1. In hardwired control, the control signals required inside the CPU can be generated using a state counter and a _____ circuit.
2. The _____ Control organization involves the control logic to be implemented with gates, flip-flops, decoders, and other digital circuits.
3. In _____ control unit, if the design has to be modified or changed, all the combinational circuits have to be modified which is a very difficult task.

11.4 Microprogrammed Control

In hardwired control, we saw how all the control signals required inside the CPU can be generated using a state counter and a PLA circuit. There is an alternative approach by which the control signals required inside the CPU can be generated. This alternative approach is known as microprogrammed control unit.

In microprogrammed control unit, the logic of the control unit is specified by a microprogram.

A microprogram consists of a sequence of instructions in a microprogramming language. These are instructions that specify microoperations.

A microprogrammed control unit is a relatively simple logic circuit that is capable of (1) sequencing through microinstructions and (2) generating control signals to execute each microinstruction.

The concept of microprogram is similar to computer program. In computer program the complete instructions of the program is stored in main memory and during execution it fetches the instructions from main memory one after another. The sequence of instruction fetch is controlled by program counter (PC) .

Microprogram are stored in microprogram memory and the execution is controlled by microprogram counter (μ PC).

Microprogram consists of microinstructions which are nothing but the strings of 0's and 1's. In a particular instance, we read the contents of one location of microprogram memory, which is nothing but a microinstruction. Each output line (data line) of microprogram memory corresponds to one control signal. If the contents of the memory cell is 0, it indicates that the signal is not generated and if the contents of memory cell is 1, it indicates to generate that control signal at that instant of time. First let me define the different terminologies that are related to microprogrammed control unit.

10.4.1 Control Word (CW)

Control word is defined as a word whose individual bits represent the various control signal. Therefore, each of the control steps in the control sequence of an instruction defines a unique combination of 0s and 1s in the CW.

A sequence of control words (CWs) corresponding to the control sequence of a machine instruction constitutes the microprogram for that instruction.

The individual control words in this microprogram are referred to as microinstructions.

The microprograms corresponding to the instruction set of a computer are stored in a special memory which will be referred to as the microprogram memory. The control words related to an instruction are stored in microprogram memory.

The control unit can generate the control signals for any instruction by sequentially reading the CWs of the corresponding microprogram from the microprogram memory. To read the control word sequentially from the microprogram memory a microprogram counter (PC) is needed.

The basic organization of a microprogrammed control unit is shown in the Figure 5.17. The "starting address generator" block is responsible for loading the starting address of the

microprogram into the μ PC everytime a new instruction is loaded in the IR. The μ PC is then automatically incremented by the clock, and it reads the successive microinstruction from memory.

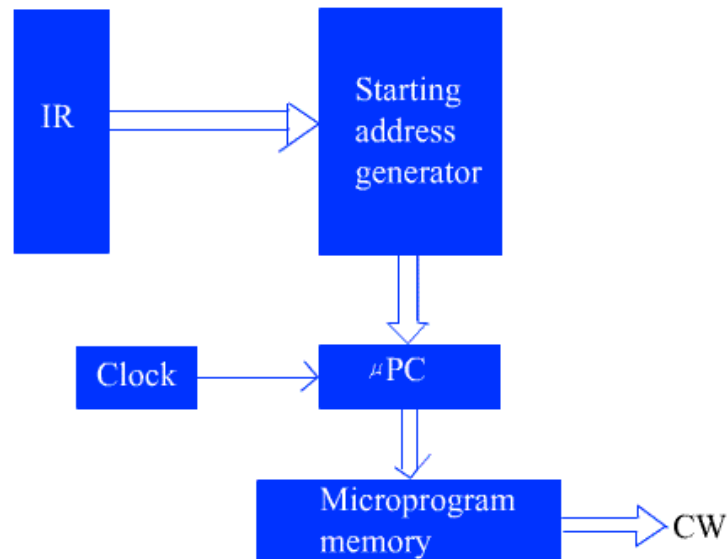

Figure 5.17: Basic organization of a microprogrammed control

Each microinstruction basically provides the required control signal at that time step. The microprogram counter ensures that the control signal will be delivered to the various parts of the CPU in correct sequence.

We have some instructions whose execution depends on the status of condition codes and status flag, as for example, the branch instruction. During branch instruction execution, it is required to take the decision between the alternative action.

To handle such type of instructions with microprogrammed control, the design of control unit is based on the concept of conditional branching in the microprogram. For that it is required to include some conditional branch microinstructions.

In conditional microinstructions, it is required to specify the address of the microprogram memory to which the control must direct. It is known as branch address. Apart from branch address, these microinstructions can specify which of the states flags, condition codes, or

possibly, bits of the instruction register should be checked as a condition for branching to take place. To support microprogram branching, the organization of control unit should be modified to accommodate the branching decision.

To generate the branch address, it is required to know the status of the condition codes and status flag. To generate the starting address, we need the instruction which is present in IR. But for branch address generation we have to check the content of condition codes and status flag.

The organization of control unit to enable conditional branching in the microprogram is shown in the Figure 5.18.

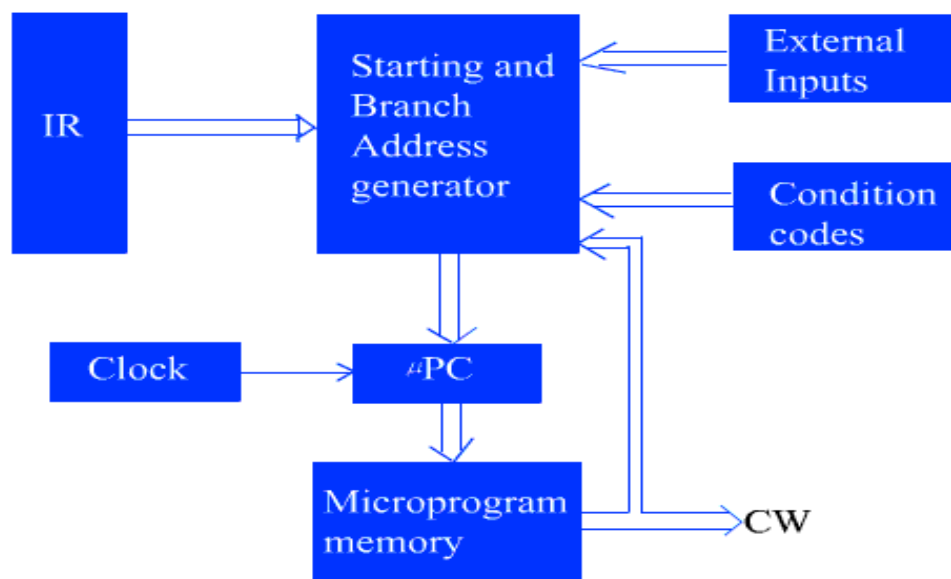

Figure 5.18: Organization of microprogrammed control with conditional branching.

The control bits of the microinstructions word which specify the branch conditions and address are fed to the "Starting and branch address generator" block. This block performs

the function of loading a new address into the μ PC when the condition of branch instruction is satisfied.

In a computer program we have seen that execution of every instruction consists of two part - fetch phase and execution phase of the instruction. It is also observed that the fetch phase of all instruction is same.

In microprogrammed controlled control unit, a common microprogram is used to fetch the instruction. This microprogram is stored in a specific location and execution of each instruction start from that memory location.

At the end of fetch microprogram, the starting address generator unit calculate the appropriate starting address of the microprogram for the instruction which is currently present in IR. After the μ PC controls the execution of microprogram which generates the appropriate control signal in proper sequence.

During the execution of a microprogram, the μ PC is always incremented everytime a new microinstruction is fetched from the microprogram memory, except in the following situations:

When an End instruction is encountered, the μ PC is loaded with the address of the first CW in the microprogram for the instruction fetch cycle.

1. When a new instruction is loaded into the IR, the PC is loaded with the starting address of the microprogram for that instruction.
2. When a branch microinstruction is encountered, and the branch condition is satisfied, the PC is loaded with the branch address.

Let us examine the contents of microprogram memory and how the microprogram of each instruction is stored or organized in microprogram memory. Consider the two example that are used in our previous lecture. First example is the control sequence for execution of the instruction "Add contents of memory location addressed in memory direct mode to register R1".

Steps	Actions
1.	PC _{out} , MAR _{in} , Read, Clear Y, Set carry-in to ALU, Add, Z _{in}
2.	Z _{out} , PC _{in} , Wait For MFC
3.	MDR _{out} , IR _{in}
4.	Address-field-of-IR _{out} , MAR _{in} , Read
5.	R1 _{out} , Y _{in} , Wait for MFC
6.	MDR _{out} , Add, Z _{in}
7.	Z _{out} , R1 _{in}
8.	END

Control sequence for Conditional Branch instruction (BRN) Branch on negative)

Steps	Actions
1.	PC _{out} , MAR _{in} , Read, Clear Y, Set Carry-in to ALU, Add, Z _{in}
2.	Z _{out} , PC _{in} , Wait for MFC
3.	MDR _{out} , IR _{in}
4.	PC _{out} , Y _{in}
5.	Address field-of IR _{out} , Add, Z _{in}
6.	Z _{out} , PC _{in}
7.	End

First consider the control signal required for fetch instruction, which is same for all the instruction, we are listing them in a particular order.

PC _{out}	MAR _{in}	Read	Clear Y	Set Carry to ALU	Add	Z _{in}	Z _{out}	PC _{in}	WMFC	MDR _{out}	IR _{in}
-------------------	-------------------	------	---------	------------------	-----	-----------------	------------------	------------------	------	--------------------	------------------

The control word for the first three steps of the above two instruction are : (which are the fetch cycle of each instruction as follows):

Step1	1	1	1	1	1	1	1	0	0	0	0	0	---
Step2	0	0	0	0	0	0	0	1	1	1	0	0	---
Step3	0	0	0	0	0	0	0	0	0	0	1	1	---

We are storing this three CW in memory location 0, 1 and 2. Each instruction starts from memory location 0. After executing upto third step, i.e., the contents of microprogram memory location 2, this control word stores the instruction in IR. The starting address generator circuit now calculate the starting address of the microprogram for the instruction which is available in IR.

Consider that the microprogram for add instruction is stored from memory location 50 of microprogram memory. So the partial contents from memory location 50 are as follows:

Location50	0	1	1	0	0	0	0	0	0	0	0	0	0	0	---	---
51	0	0	0	0	0	0	0	0	0	0	1	0	0	---	---	

and so on

The contents of the compile instruction is given below:

1 - PCin, 2 - PCout, 3 - MARin, 4 - Read, 5 - MDRout, 6 - IRin, 7 - , 8 - Yin, 9 - Clear Y,
10 - Carry-in, 11 - add, 12 - Zin, 13 - Zout, 14 -RIout, 15 - Rlin, 16 - WMFC, 17 - END

When the microprogram executes the End microinstruction of an instruction, then it generates the End control signal. This End control signal is used to load the PC with the starting address of fetch instruction (In our case it is address 0 of microprogram memory). Now the CPU is ready to fetch the next instruction from main memory.

Memory Location	-----	1	2	3		4	5	6	7	8	9	10	11	12	13	14	15	16	17	-----
0	-----	0	1	1		1	0	0	0	0	1	1	1	1	0	0	0	0	0	-----
1		1	0	0		0	0	0	0	0	0	0	0	0	1	0	0	1	0	-----
2		0	0	0		0	1	1	0	0	0	0	0	0	0	0	0	0	0	-----
50		0	0	1		1	0	0	1	0	0	0	0	0	0	0	0	0	0	
51		0	0	0		0	0	0	0	1	0	0	0	0	0	1	0	1	0	
52		0	0	0		0	1	0	0	0	0	0	1	1	0	0	0	0	0	
53		0	0	0		0	0	0	0	0	0	0	0	0	1	0	1	0	0	
54		0	0	0		0	0	0	0	0	0	0	0	0	0	0	0	0	0	1

From the discussion, it is clear that microprograms are similar to computer program, but it is in one level lower, that's why it is called microprogram.

For each instruction of the instruction set of the CPU, we will have a microprogram.

While executing a computer program, we fetch instruction by instruction from main memory which is controlled by program counter(PC).

When we fetch an instruction from main memory, to execute that instruction, we execute the microprogram for that instruction. Microprograms are nothing but the collection of microinstructions. These microinstructions will be fetched from microprogram memory one after another and its sequence is maintained by μ PC. Fetching of microinstruction basically provides the required control signal at that time instant.

To design a micro programmed control unit, we have to do the following:

- For each instruction of the CPU, we have to write a microprogram to generate the control signal. The microprograms are stored in microprogram memory (control store). The starting address of each microprogram are known to the designer
- Each microprogram is the sequence of microinstructions. And these microinstructions are executed in sequence. The execution sequence is maintained by microprogram counter.
- Each microinstruction is nothing but the combination of 0's and 1's which is known as control word. Each position of control word specifies a particular control signal. 0 on the control word means that a low signal value is generated for that control signal at that particular instant of time, similarly 1 indicates a high signal.
- Since each machine instruction is executed by a corresponding micro routine, it follows that a starting address for the micro routine must be specified as a function of the contents of the instruction register (IR).
- To incorporate the branching instruction, i.e., the branching within the microprogram, a branch address generator unit must be included. Both unconditional and conditional branching can be achieved with the help of microprogram. To incorporate the conditional branching instruction, it is required to check the contents of condition code and status flag.

Microprogramed controlled control unit is very much similar to CPU. In CPU the PC is used to fetch instruction from the main memory, but in case of control unit, microprogram counter is used to fetch the instruction from control store.

But there are some differences between these two. In case of fetching instruction from main memory, we are using two signals MFC and WMFC. These two signals are required to synchronize the speed between CPU and main memory. In general, main memory is a slower device than the CPU.

In microprogrammed control the need for such signal is less obvious. The size of control store is less than the size of main memory. It is possible to replace the control store by a faster memory, where the speed of the CPU and control store is almost same.

Since control store are usually relatively small, so that it is feasible to speed up their speed through costly circuits.

If we can implement the main memory by a faster device then it is also possible to eliminate the signals MFC & WMFC. But, in general, the size of main memory is very big and it is not economically feasible to replace the whole main memory by a faster memory to eliminate MFC & WMFC.

11.5 Grouping of control signals

It is observed that we need to store the information of each control signal in control store. The status of a particular control signal is either high or low at a particular instant of time.

It is possible to reserve one-bit position for each control signal. If there are n control signals in a CPU, then the length of each control signal is n . Since we have one bit for each control signal, so a large number of resources can be controlled with a single microinstruction. This organization of microinstruction is known as horizontal organization.

If the machine structure allows parallel uses of a number of resources, then horizontal organization has got advantage. Since a greater number of resources can be accessed parallel, the operating speed is also more in such organization. In this situation, horizontal organization of control store has got advantage.

If more number of resources can be accessed simultaneously, than most of the contents of control store is 0. Since the machine architecture does not provide the parallel access of resources, so simultaneously we cannot generate the control signal. In such situation, we can combine some control signals and group them together. This will reduce the size of control word. If we use compact code to specify only a small number of control functions in each microinstruction, then it is known as vertical organization of microinstruction.

In case of horizontal organization, the size of control word is longer, which is in one extreme point and in case of vertical organization, the size of control word is smaller, which is in other extreme.

In case of horizontal organization, the implementation is simple, but in case of vertical organization, implementation complexity increases due to the required decoder circuits. Also, the complexity of decoder depends on the level of grouping and encoding of the control signal.

Horizontal and Vertical organization represent the two organizational extremes in microprogrammed control. Many intermediate schemes are also possible, where the degree of encoding is a design parameter.

We will explain the grouping of control signal with the help of an example. Grouping of control signals depends on the internal organization of CPU.

Assigning individual bits to each control signal is certain to lead to long microinstruction, since the number of required control signals is normally large.

However, only a few bits are set to 1 and therefore used for active gating in any given microinstructions. This obviously results in low utilization of the available bit space.

If we group the control signal in some non-overlapping group then the size of control word reduces.

The single bus architecture of CPU is shown in the Figure 5.19.

This CPU contains four general purpose registers R0 , R1 , R2 and R3 . In addition there are three other register called SOURCES, DESTIN and TEMP. These are used for temporary storage within the CPU and completely transparent to the programmer. A computer programmer cannot use these three registers.

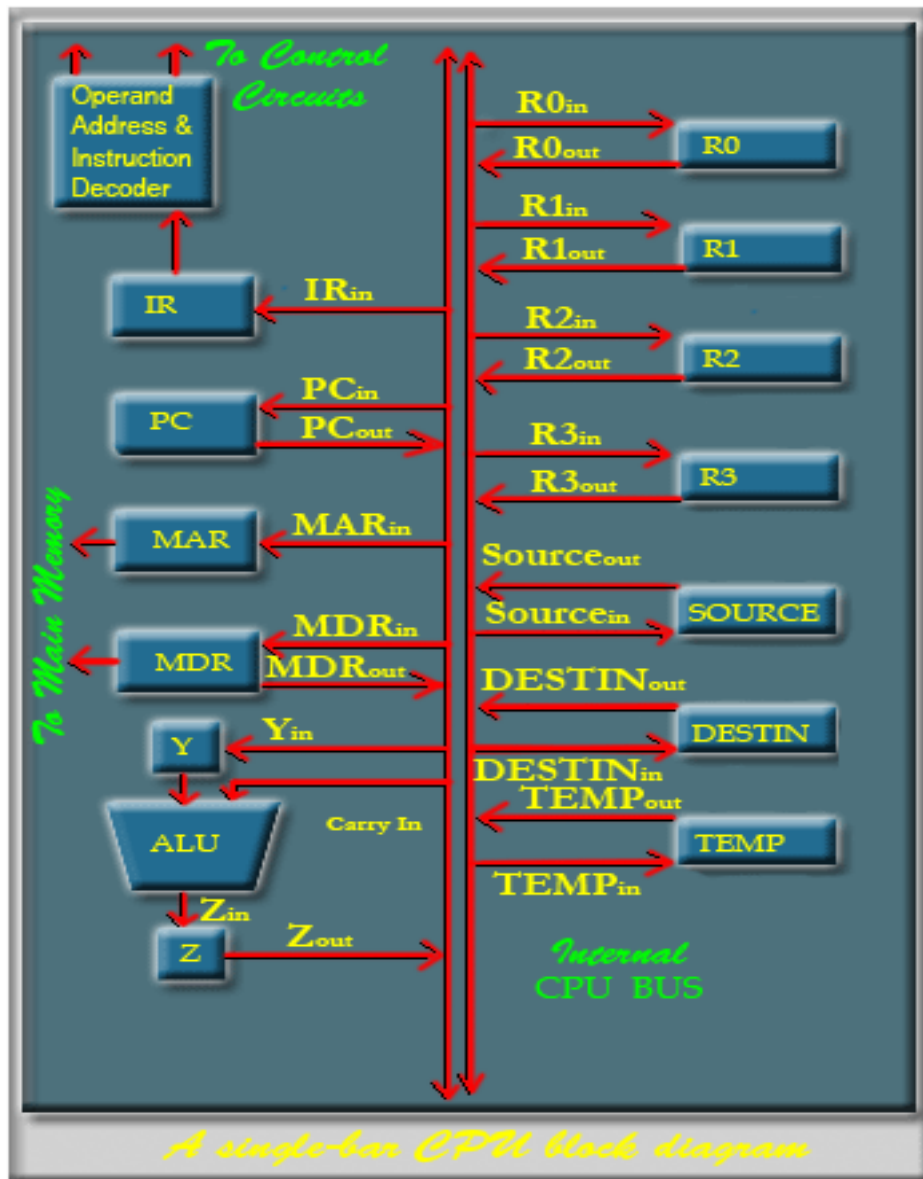

Figure 5.19: Single bus architecture of CPU

For the proper functioning of this CPU, we need all together 24 gating signals for the transfer of information between internal CPU bus and other resources like registers.

In addition to these register gating signals, we need some other control signals which include the Read, Write, Clear Y, set carry in, WMFC, and End signal. (Here we are restricting the control signal for the case of discussion in reality, the number of signals are more).

It is also necessary to specify the function to be performed by ALU. Depending on the power of ALU, we need several control lines, one control signal for each function. Assume that the ALU that is used in the design can perform 16 different operation such as ADD, SUBSTRACT, AND, OR, etc. So, we need 16 different control lines.

If is observed that most signals are not needed simultaneously and many signals are mutually exclusive.

As for example, only one function of the ALU can be activated at a time. In our case we are considering 16 ALU operations. Instead of using 16 different signal for ALU operation, we can group them together and reduce the number of control signal. From digital logic circuit, it is obvious that instead of 16 different signal, we can use only 4 control signal for ALU operation and then use a 4 X 16 decoder to generate 16 different ALU signals. Due to the use of a decoder, there is a reduction in the size of control word.

Another possibility of grouping control signal is: A sources for data transfer must be unique, which means that it is not possible to gate the contents of two different registers onto the bus at the same time. Similarly Read Write signals to the memory cannot be activated simultaneously.

This observation suggests the possibilities of grouping the signals so that all signals that are mutually exclusive are placed in the same group. Thus a group can specify one micro operation at a time.

At that point we have to use a binary coding scheme to represent a given signal within a group. As for example, for 16 ALU function, four bits are enough to decode the appropriate function.

A possible grouping of the 46 control signals that are required for the above mention CPU is given in the Table 5.1.

Table 5.1: Grouping of the control signals

F1 (4 bits)	F2 (3 bits)	F3 (2 bits)	F4 (2 bits)	F5 (4 bits)
0000 : No Transfer	000 : No Transfer	00 : No Transfer	00 : No Transfer	0000 : Add
0001 : PC _{out}	001 : PC _{in}	01 : MAR _{in}	01 : Yin	0001 : Sub
0010 : MDR _{out}	001 : IR _{in}	10 : MDR _{in}	10 : SOURCE _{in}	0010 : MULT
0011 : Z _{out}	011 : Z _{in}	11 : TEMP _{in}	11 : DESTIN _{in}	0011 : Div
0100 : R0 _{out}	100 : R0 _{in}			
0101 : R1 _{out}	101 : R1 _{in}			
0110 : R2 _{out}	110 : R2 _{in}			
0111 : R3 _{out}	111 : R3 _{in}			
1000 : SOURCE _{out}				
1001 : DESTIN _{out}				
1010 : TEMP _{out}				
1011 : ADDRESS _{out}				1111 : XOR

F6 (2 bits)	F7 (1 bit)	F8 (1 bit)	F9 (1 bit)	F10 (1 bit)
00 : no action	0 : no action	0 : carry-in=0	0 : no action	0 : continue
01 : read	1 : clear Y	1 : carry-in=1	1 : WMFC	1 : end
10 : write				

A possible grouping of signal is shown here. There may be some other grouping of signal possible. Here all out- gating of registers are grouped into one group, because the contents

of only one bus is allowed to go to the internal bus, otherwise there will be a conflict of data.

But the in-gating of registers are grouped into three different group. It implies that the contents of the bus may be stored into three different registers simultaneously transfer to MAR and Z. Due to this grouping, we are using 7 bits (3+2+2) for the in-gating signal. If we would have grouped then in one group, then only 4 bits would have been enough; but it will take more time during execution. In this situation, two clock cycles would have been required to transfer the contents of PC to MAR and Z.

Therefore, the grouping of signal is a critical design parameter. If speed of operation is also a design parameter, then compression of control word will be less.

In this grouping, 46 control signals are grouped into 10 different groups (F1 , F2 ,....., F10) and the size of control word is 21. So, the size of control word is reduced from 46 to 21, which is more than 50%.

For the proper decoding, we need the following decoder:

For group F1 & F5 : 4 X 16 decoder,

group F2 : 3 X 8 decoder

group F3,F4 & F6 : 2 X 4 decoder

11.6 Microprogram Sequencing

In microprogrammed controlled CU,

- Each machine instruction can be implemented by a micro routine.
- Each micro routine can be accessed initially by decoding the machine instruction into the starting address to be loaded into the PC.

Writing a microprogram for each machine instruction is a simple solution, but it will increase the size of control store.

We have already discussed that most machine instructions can operate in several addressing modes. If we write different microroutine for each addressing mode, then most of the cases, we are repeating some part of the microroutine.

The common part of the microroutine can be shared by several microroutine, which will reduce the size of control store. This results in a considerable number of branch microinstructions being needed to transfer control among various parts. So, it introduces branching capabilities within the microinstruction.

This indicates that the microprogrammed control unit has to perform two basic tasks:

- Microinstruction sequencing: Get the next microinstruction from the control memory.
- Microinstruction execution: Generate the control signals needed to execute the microinstruction.

In designing a control unit, these tasks must be considered together, because both affect the format of the microinstruction and the timing of control unit.

11.6.1 Design Consideration

Two concerns are involved in the design of a microinstruction sequencing technique: the size of the microinstruction and the address generation time.

In executing a microprogram, the address of the next microinstruction to be executed is in one of these categories:

- Determined by instruction register
- Next sequential address
- Branch

11.6.2 Sequencing Techniques

Based on the current microinstruction, condition flags and the contents of the instruction register, a control memory address must be generated for the next microinstruction. A wide variety of techniques have been used and can be grouped them into three general categories:

- Two address fields
- Single address field
- Variable format.

11.6.2.1 Two Address fields

The branch control logic with two-address field is shown in the Figure 5.20.

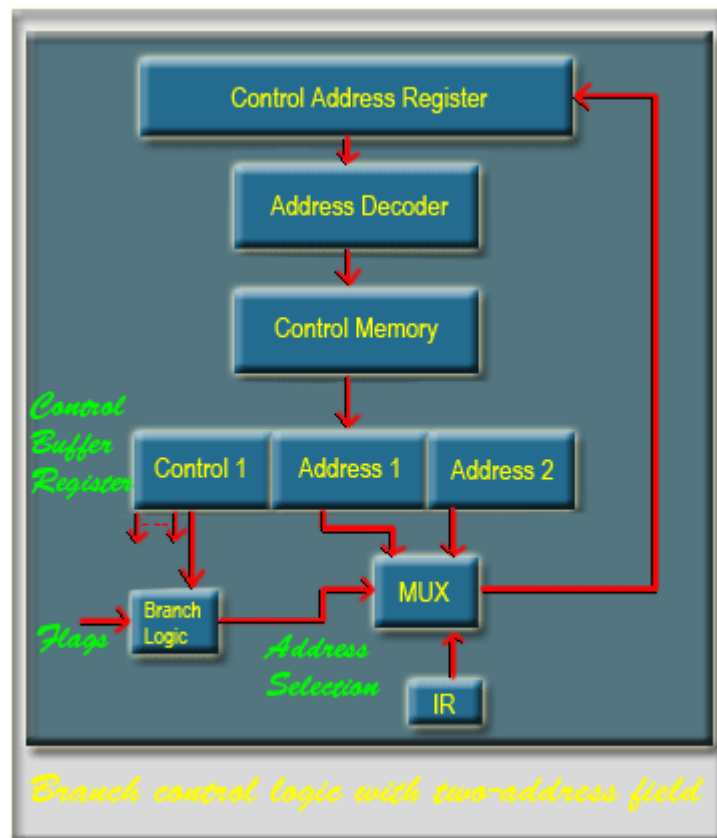

Figure 5.20: Branch control logic with two address field

A multiplier is provided that serves as a destination for both address fields and the instruction register. Based on an address selection input, the multiplexer selects either the opcode or one of the two addresses to the control address register (CAR). The CAR is subsequently decoded to produce the next microinstruction address. The address selection signals are provided by a branch logic module whose input consists of control unit flags plus bits from the control portion of the microinstruction.

11.6.2.2 Single address field

The two-address approach is simple but it requires more bits in the microinstruction. With some additional logic, savings can be achieved. The approach is shown in the Figure 5.21.

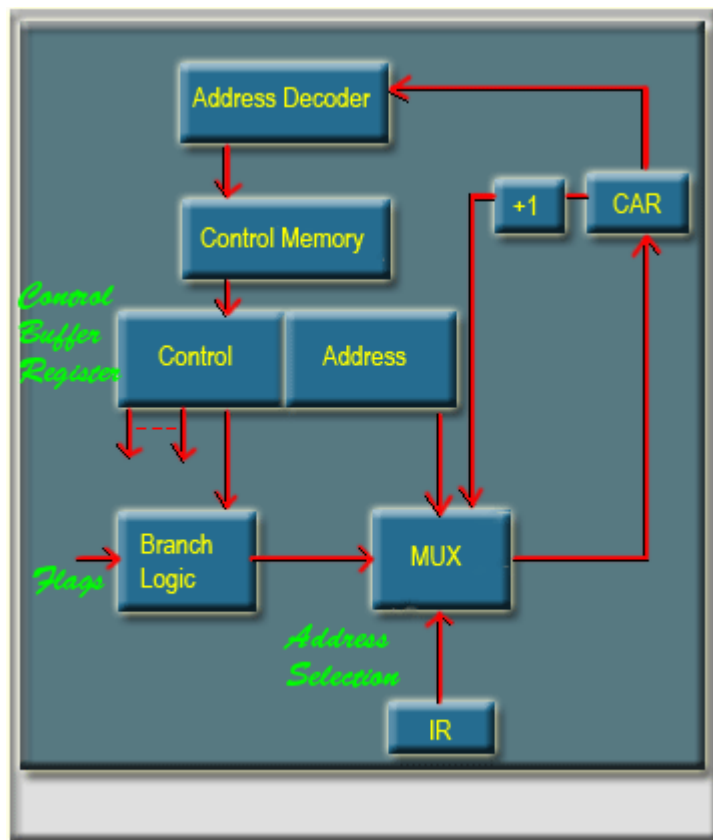

Figure 5.21: Branch control logic with one address field

In this single address field branch control logic, the options for next address are as follows:

- Address field
- Instruction register code
- Next sequential address

The address selection signals determine which option to be selected. This approach reduces the number of address fields to one.

11.6.2.3 Variable format

In variable format branch control logic one bit designates which format is being used. In one format, the remaining bits are used to active control signals. In the other format, some bits drive the branch logic module, and the remaining bits provide the address. With the first format, the next address is either the next sequential address or an address derived from the instruction register. With the second format, either a conditional or unconditional branch is being specified. The approach is shown in the Figure 5.22.

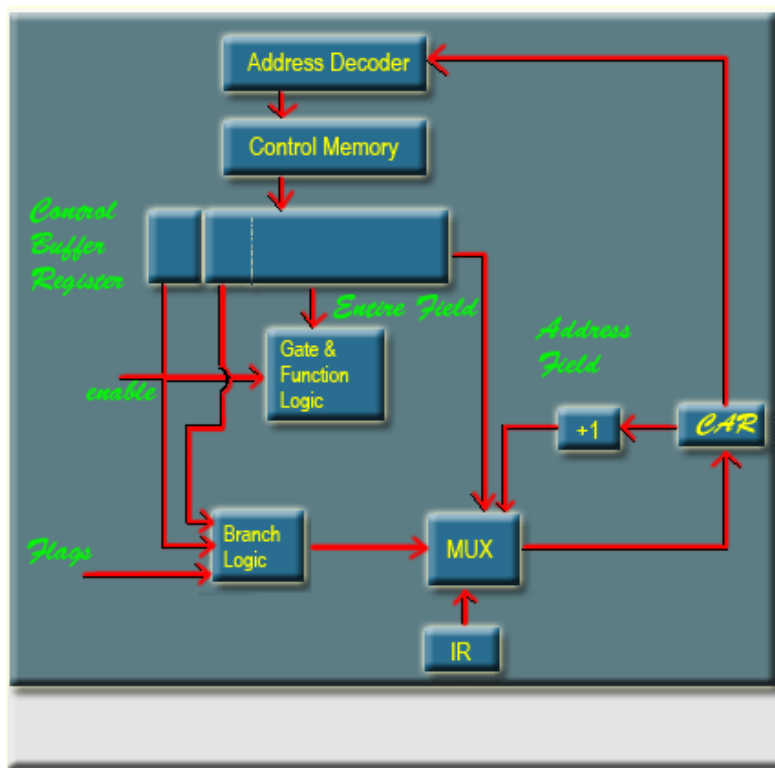

Figure 5.22: Branch control logic with variable format

11.6.3 Address Generation

We have looked at the sequencing problem from the point of view of format consideration and general logic requirements. Another viewpoint is to consider the various ways in which the next address can be derived or computed.

Various address generation Techniques	
<i>Explicit</i>	<i>Implicit</i>
Two-field	Mapping
Unconditional branch	Addition
Conditional branch	Residual control

The address generation technique can be divided into two techniques: explicit & implicit.

In explicit technique, the address is explicitly available in the microinstruction.

In implicit technique, additional logic circuit is used to generate the address.

In two address field approach, signal address field or a variable format, various branch instruction can be implemented with the explicit approaches.

In implicit technique, mapping is required to get the address of next instruction. The opcode portion of a machine instruction must be mapped into a microinstruction address.



Check your progress II

1. _____ control unit is slower in speed because of the time it takes to fetch microinstructions from the control memory.
2. In _____ technique, the address is explicitly available in the microinstruction.
3. In _____ technique, additional logic circuit is used to generate the address.
4. A _____ is a word whose individual bits represent various control signals.

5. Microprogram are stored in microprogram memory and the execution is controlled by _____ counter.

11.7 Summary

1. To generate the control signal in proper sequence, two categories of techniques exists, Hardwired Control and Microprogrammed Control.
2. In this hardwired control techniques, the control signals are generated by means of hardwired circuit.
3. In VLSI technology, structure that involve regular interconnection patterns are much easier to implement than the random connections.
4. PLAs are the arrays of AND gates followed by array of OR gates.
5. In microprogrammed control unit, the logic of the control unit is specified by a microprogram.
6. Control word is defined as a word whose individual bits represent the various control signal.
7. A sequence of control words (CWs) corresponding to the control sequence of a machine instruction constitutes the microprogram for that instruction.
8. The individual control words in this microprogram are referred to as microinstructions.
9. For each instruction of the instruction set of the CPU, we will have a microprogram.
10. While executing a computer program, we fetch instruction by instruction from main memory which is controlled by program counter(PC).
11. In microprogrammed controlled CU, each machine instruction can be implemented by a micro-routine.
12. The address generation technique can be divided into two techniques: explicit & implicit.

11.8 Model Questions

1. Discuss about the hardwired implementation of the control unit.
2. Discuss about the microprogrammed implementation of the control unit.
3. Write the difference between hardwired and microprogrammed control unit.
4. What is PLA?
5. What is Control Word?
6. What is conditional branching? Explain the organization of microprogrammed control with conditional branching.
7. Explain Microprogram Sequencing.
8. What are the various concerns involved in the design of a microinstruction sequencing technique?
9. Explain various sequencing techniques.



Answers to Check your progress I

1. PLA
2. hardwired
3. hardwired



Answers to Check your progress II

1. Micro-programmed
2. explicit
3. implicit
4. control word
5. microprogram

INPUT/OUTPUT DEVICE

12.0 Learning Objectives

After completing this unit, the learner shall be able to:

- Explain the reasons why an I/O device or peripheral device is not directly connected to the system bus;
- Know the major functions of an I/O module;
- Explain the various steps involved in Processor & Device Communication;
- Explain the functioning of an I/O module using a block diagram;
- Know the various addressing modes between CPU and I/O devices;
- Differentiate between Memory mapped and Isolated I/O;
- Explain basic forms of input and output systems;
- Know various types of I/O commands that an I/O module will receive when it is addressed by a processor;
- Explain Interrupt processing;
- Know the design Issues for Interrupt;
- Understand possible arrangement to handle multiple interrupt;
- Explain Direct Memory Access;

12.1 Input/Output Organization

The computer system's input/output (I/O) architecture is its interface to the outside world.

Till now we have discussed the two important modules of the computer system –

- The processor and
- The memory module.

The third key component of a computer system is a set of I/O modules. Each I/O module interfaces to the system bus and controls one or more peripheral devices.

There are several reasons why an I/O device or peripheral device is not directly connected to the system bus. Some of them are as follows -

- There are a wide variety of peripherals with various methods of operation. It would be impractical to include the necessary logic within the processor to control several devices.
- The data transfer rate of peripherals is often much slower than that of the memory or processor. Thus, it is impractical to use the high-speed system bus to communicate directly with a peripheral.
- Peripherals often use different data formats and word lengths than the computer to which they are attached.

Thus, an I/O module is required.

12.1.1 Input/Output Modules

The major functions of an I/O module are categorized as follows –

- Control and timing
- Processor Communication
- Device Communication
- Data Buffering
- Error Detection

During any period of time, the processor may communicate with one or more external devices in unpredictable manner, depending on the program's need for I/O. The internal resources, such as main memory and the system bus, must be shared among a number of activities, including data I/O.

12.1.2 Control & timings

The I/O function includes a control and timing requirement to co-ordinate the flow of traffic between internal resources and external devices. For example, the control of the transfer of data from an external device to the processor might involve the following sequence of steps –

- The processor interacts with the I/O module to check the status of the attached device.
- The I/O module returns the device status.

- If the device is operational and ready to transmit, the processor requests the transfer of data, by means of a command to the I/O module.
- The I/O module obtains a unit of data from external device.
- The data are transferred from the I/O module to the processor.

If the system employs a bus, then each of the interactions between the processor and the I/O module involves one or more bus arbitrations.

12.1.3 Processor & Device Communication

During the I/O operation, the I/O module must communicate with the processor and with the external device. Processor communication involves the following -

Command decoding: The I/O module accepts command from the processor, typically sent as signals on control bus.

Data: Data are exchanged between the processor and the I/O module over the data bus.

Status Reporting: Because peripherals are so slow, it is important to know the status of the I/O module. For example, if an I/O module is asked to send data to the processor(read), it may not be ready to do so because it is still working on the previous I/O command. This fact can be reported with a status signal. Common status signals are BUSY and READY.

Address Recognition: Just as each word of memory has an address, so thus each of the I/O devices. Thus, an I/O module must recognize one unique address for each peripheral it controls.

On the other hand, the I/O must be able to perform device communication. This communication involves command, status information and data.

Data Buffering: An essential task of an I/O module is data buffering. The data buffering is required due to the mismatch of the speed of CPU, memory and other peripheral devices. In general, the speed of CPU is higher than the speed of the other peripheral devices. So, the I/O modules store the data in a data buffer and regulate the transfer of data as per the speed of the devices.

In the opposite direction, data are buffered so as not to tie up the memory in a slow transfer operation. Thus, the I/O module must be able to operate at both device and memory speed.

Error Detection: Another task of I/O module is error detection and for subsequently reporting error to the processor. One class of error includes mechanical and electrical malfunctions reported by the device (e.g. paper jam). Another class consists of unintentional changes to the bit pattern as it is transmitted from devices to the I/O module.

Block diagram of I/O Module is shown in the Figure 6.1.

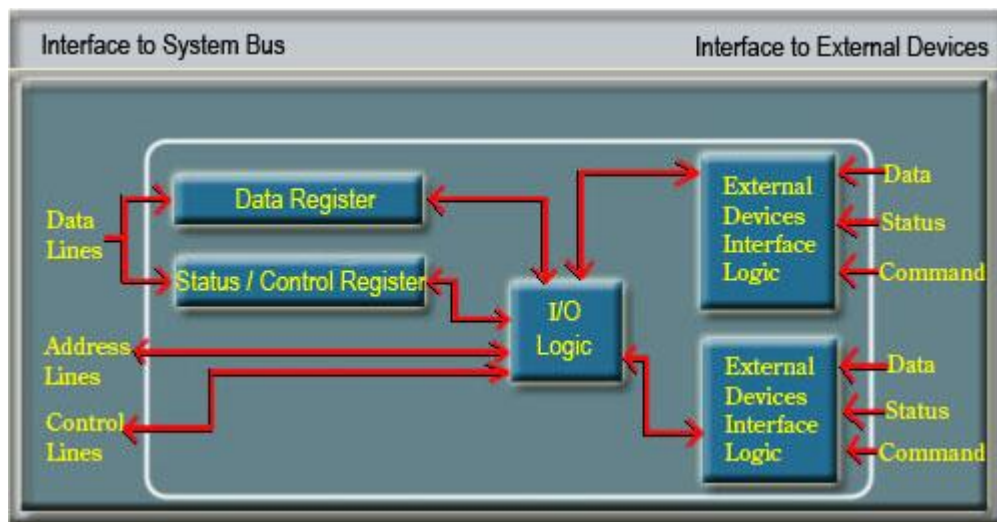

Figure 6.1: Block diagram of I/O Module

There will be many I/O devices connected through I/O modules to the system. Each device will be identified by a unique address.

When the processor issues an I/O command, the command contains the address of the device that is used by the command. The I/O module must interpret the address lines to check if the command is for itself. Generally in most of the processors, the processor, main memory and I/O share a common bus(data address and control bus).

Two types of addressing are possible:

- Memory-mapped I/O
- Isolated or I/O mapped I/O

Memory-mapped I/O

There is a single address space for memory locations and I/O devices. The processor treats the status and address register of the I/O modules as memory location. For example, if the size of address bus of a processor is 16, then there are 2^{16} combinations and all together 2^{16} address locations can be addressed with these 16 address lines.

Out of these 2^{16} address locations, some address locations can be used to address I/O devices and other locations are used to address memory locations.

Since I/O devices are included in the same memory address space, so the status and address registers of I/O modules are treated as memory location by the processor. Therefore, the same machine instructions are used to access both memory and I/O devices.

Isolated or I/O -mapped I/O

In this scheme, the full range of addresses may be available for both. The address refers to a memory location or an I/O device is specified with the help of a command line.

In general command line IO/\bar{M} is used to identify a memory location or an I/O device.

if $IO/\bar{M}=1$, it indicates that the address present in address bus is the address of an I/O device.

if $IO/\bar{M}=0$, it indicates that the address present in address bus is the address of a memory location.

Since full range of address is available for both memory and I/O devices, so, with 16 address lines, the system may now support both 2^{16} memory locations and 2^{16} I/O addresses

12.2 Input / Output Subsystem

There are three basic forms of input and output systems:

- Programmed I/O
- Interrupt driven I/O
- Direct Memory Access(DMA)

With programmed I/O, the processor executes a program that gives its direct control of the I/O operation, including sensing device status, sending a read or write command, and transferring the data.

With interrupt driven I/O, the processor issues an I/O command, continues to execute other instructions, and is interrupted by the I/O module when the I/O module completes its work.

In Direct Memory Access (DMA), the I/O module and main memory exchange data directly without processor involvement.

With both programmed I/O and Interrupt driven I/O, the processor is responsible for extracting data from main memory for output operation and storing data in main memory for input operation.

To send data to an output device, the CPU simply moves that data to a special memory location in the I/O address space if I/O mapped input/output is used or to an address in the memory address space if memory mapped I/O is used.

	I/O Address Space (in memory)	if I/O mapped input/output is used
Data	memory address space	if memory mapped I/O is used

To read data from an input device, the CPU simply moves data from the address (I/O or memory) of that device into the CPU.

Input/Output Operation: The input and output operation looks very similar to a memory read or write operation except it usually takes more time since peripheral devices are slow in speed than main memory modules.

The working principle of the three methods for input of a Block of Data is shown in the Figure 6.2.

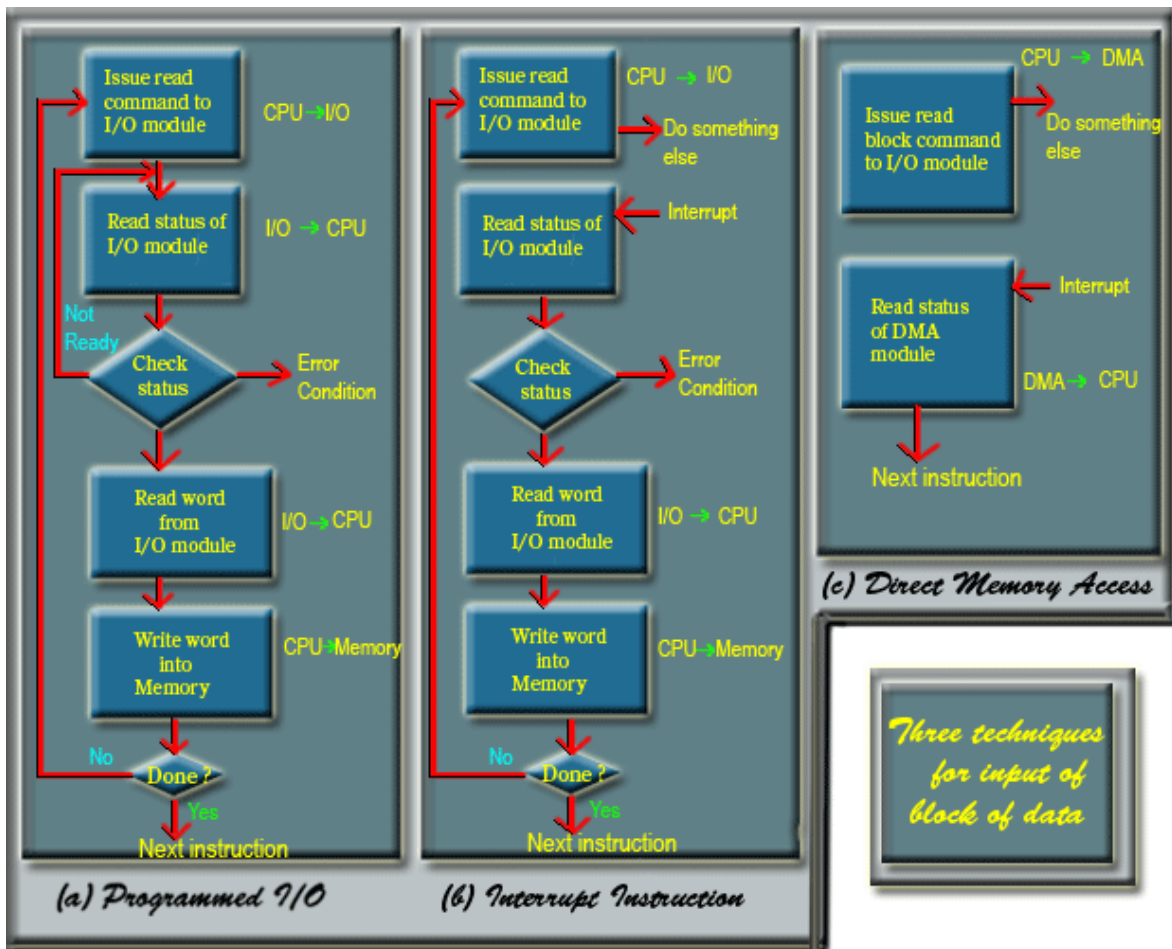

Figure 6.2: Working of three techniques for input of block of data

12.3 Input/Output Port

An I/O port is a device that looks like a memory cell to the computer but contains connection to the outside world. An I/O port typically uses a latch. When the CPU writes to the address associated with the latch, the latch device captures the data and makes it available on a set of wires external to the CPU and memory system. The I/O ports can be read-only, write-only, or read/write. The write-only port is shown in the Figure 6.3.

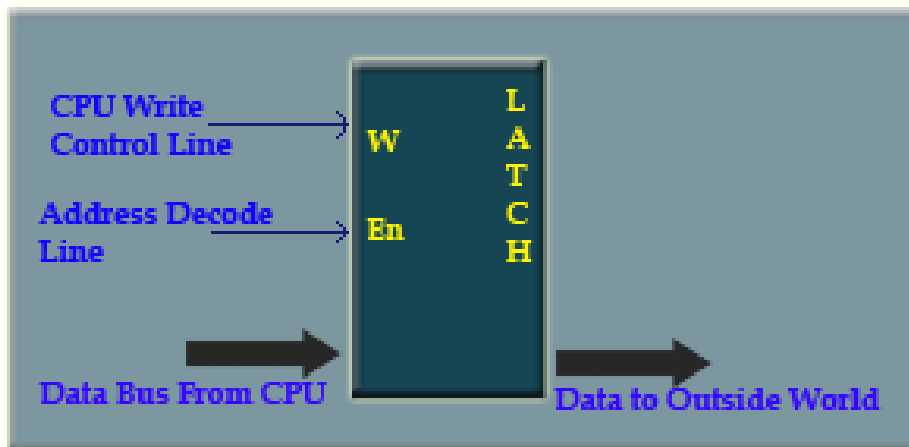

Figure 6.3: The write only port

First, the CPU will place the address of the device on the I/O address bus and with the help of address decoder a signal is generated which will enable the latch. Next, the CPU will indicate the operation is a write operation by putting the appropriate signal in CPU write control line. Then the data to be transferred will be placed in the CPU bus, which will be stored in the latch for the onward transmission to the device. Both the address decode and write control lines must be active for the latch to operate. The read/write or input/output port is shown in the Figure 6.4.

The device is identified by putting the appropriate address in the I/O address lines. The address decoder will generate the signal for the address decode lines. According to the operation, read or write, it will select either of the latch. If it is a write operation, then data will be placed in the latch from CPU for onward transmission to the output device.

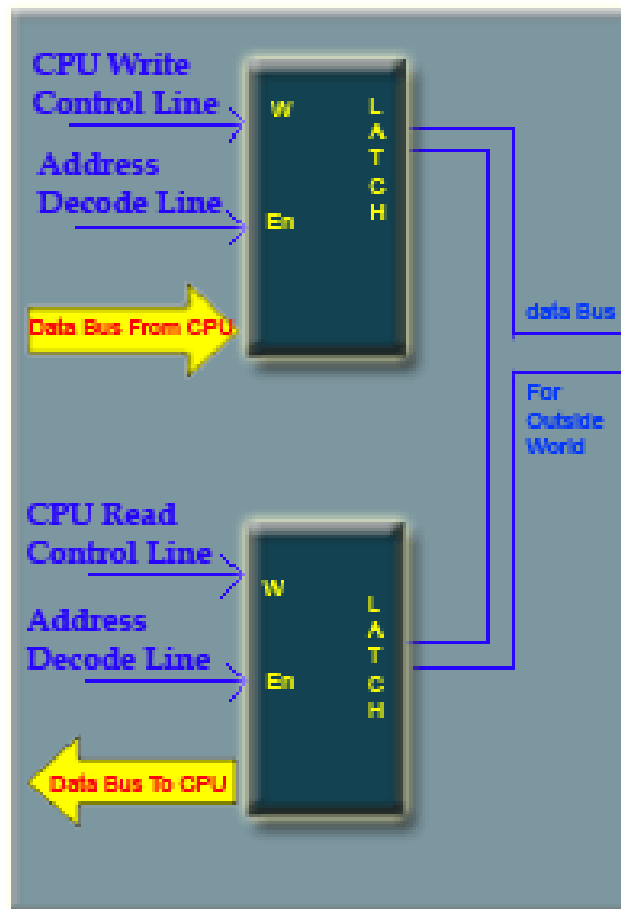

Figure 6.4: Read / Write port

If it is in a read operation, the data that are already stored in the latch will be transferred to the CPU. A read only (input) port is simply the lower half of the Figure 6.4. In case of I/O mapped I/O, a different address space is used for I/O devices. The address space for memory is different. In case of memory mapped I/O, same address space is used for both memory and I/O devices. Some of the memory address space are kept reserved for I/O devices. To the programmer, the difference between I/O-mapped and memory-mapped input/output operation is the instruction to be used. For memory-mapped I/O, any instruction that accessed memory can access a memory-mapped I/O port. I/O-mapped input/output uses special instruction to access I/O port.

Generally, a given peripheral device will use more than a single I/O port. A typical PC parallel printer interface, for example, uses three ports, a read/write port, an input port and an output port. The read/write port is the data port (it is read/write to allow the CPU to read the last ASCII character it wrote to the printer port).

The input port returns control signals from the printer.

- These signals indicate whether the printer is ready to accept another character, is off-line, is out of paper, etc.

The output port transmits control information to the printer such as:

- whether data is available to print.

Memory-mapped I/O subsystems and I/O-mapped subsystems both require the CPU to move data between the peripheral device and main memory.

For example, to input a sequence of 20 bytes from an input port and store these bytes into memory, the CPU must send each value and store it into memory.



Check your progress I

1. _____ connected to a computer need special communication links for interfacing them with the central processing unit.
2. In _____ we have common bus(data and address) for I/O and memory but separate read and write control lines for I/O.
3. In _____ every bus in common due to which the same set of instructions work for memory and I/O.

12.4 Programmed I/O

In programmed I/O, the data transfer between CPU and I/O device is carried out with the help of a software routine.

When a processor is executing a program and encounters an instruction relating to I/O, it executes that I/O instruction by issuing a command to the appropriate I/O module.

The I/O module will perform the requested action and then set the appropriate bits in the I/O status register.

The I/O module takes no further action to alert the processor.

It is the responsibility of the processor to check periodically the status of the I/O module until it finds that the operation is complete.

In programmed I/O, when the processor issues a command to a I/O module, it must wait until the I/O operation is complete.

Generally, the I/O devices are slower than the processor, so in this scheme CPU time is wasted. CPU is checking the status of the I/O module periodically without doing any other work.

12.4.1 I/O Commands

To execute an I/O-related instruction, the processor issues an address, specifying the particular I/O module and external device, and an I/O command. There are four types of I/O commands that an I/O module will receive when it is addressed by a processor –

- Control: Used to activate a peripheral device and instruct it what to do. For example, a magnetic tape unit may be instructed to rewind or to move forward one record. These commands are specific to a particular type of peripheral device.
- Test: Used to test various status conditions associated with an I/O module and its peripherals. The processor will want to know if the most recent I/O operation is completed or any error has occurred.

- Read: Causes the I/O module to obtain an item of data from the peripheral and place it in the internal buffer.
- Write: Causes the I/O module to take an item of data (byte or word) from the data bus and subsequently transmit the data item to the peripheral.

12.5 Interrupt driven I/O

The problem with programmed I/O is that the processor has to wait a long time for the I/O module of concern to be ready for either reception or transmission of data. The processor, while waiting, must repeatedly interrogate the status of the I/O module.

This type of I/O operation, where the CPU constantly tests a part to see if data is available, is polling, that is, the CPU Polls (asks) the port if it has data available or if it is capable of accepting data. Polled I/O is inherently inefficient.

The solution to this problem is to provide an interrupt mechanism. In this approach the processor issues an I/O command to a module and then go on to do some other useful work. The I/O module then interrupt the processor to request service when it is ready to exchange data with the processor. The processor then executes the data transfer. Once the data transfer is over, the processor then resumes its former processing.

Let us consider how it works

A. From the point of view of the I/O module:

- For input, the I/O module services a READ command from the processor.
- The I/O module then proceeds to read data from an associated peripheral device.
- Once the data are in the modules data register, the module issues an interrupt to the processor over a control line.
- The module then waits until its data are requested by the processor.
- When the request is made, the module places its data on the data bus and is then ready for another I/O operation

B. From the processor point of view; the action for an input is as follows: :

- The processor issues a READ command.
- It then does something else (e.g. the processor may be working on several different programs at the same time)
- At the end of each instruction cycle, the processor checks for interrupts
- When the interrupt from an I/O module occurs, the processor saves the context (e.g. program counter & processor registers) of the current program and processes the interrupt.
- In this case, the processor reads the word of data from the I/O module and stores it in memory.
- It then restores the context of the program it was working on and resumes execution.

12.5.1 Interrupt Processing

The occurrence of an interrupt triggers a number of events, both in the processor hardware and in software. When an I/O device completes an I/O operation, the following sequences of hardware events occurs:

- The device issues an interrupt signal to the processor.
- The processor finishes execution of the current instruction before responding to the interrupt.
- The processor tests for the interrupt; if there is one interrupt pending, then the processor sends an acknowledgement signal to the device which issued the interrupt. After getting acknowledgement, the device removes its interrupt signals.
- The processor now needs to prepare to transfer control to the interrupt routine. It needs to save the information needed to resume the current program at the point of interrupt. The minimum information required to save is the processor status word (PSW) and the location of the next instruction to be executed which is nothing but the contents of program counter. These can be pushed into the system control stack.
- The processor now loads the program counter with the entry location of the interrupt handling program that will respond to the interrupt.
- Next, the program counter is loaded with the starting address of the interrupt service routine.
- Processor starts executing the interrupt service routine.

The data changes of memory and registers during interrupt service is shown in the Figure 6.5.

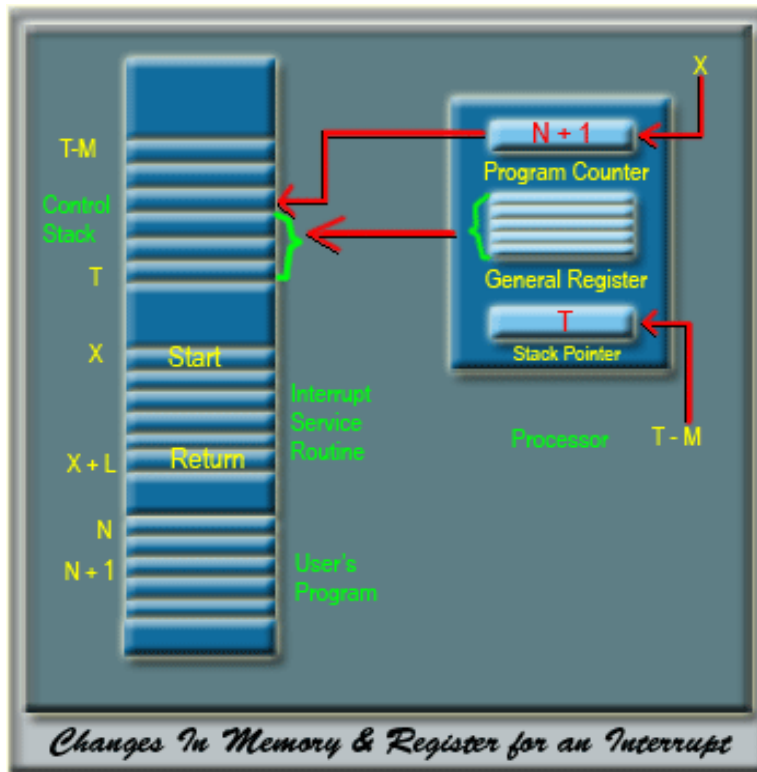

Figure 6.5: Changes of memory and register for an interrupt

12.5.2 Return from Interrupt

- Interrupt service routine starts at location X and the return instruction is in location X + L.
- After fetching the return instruction, the value of program counter becomes X + L + 1.
- While returning to user's program, processor must restore the earlier values.
- From control stack, it restores the value of program counter and the general registers.
- Accordingly, it sets the value of the top of the stack and accordingly stack pointer is updated.
- Now the processor starts execution of the user's program (interrupted program) from memory location N + 1.

The data changes of memory and registers during return from and interrupt is shown in the Figure 6.6.

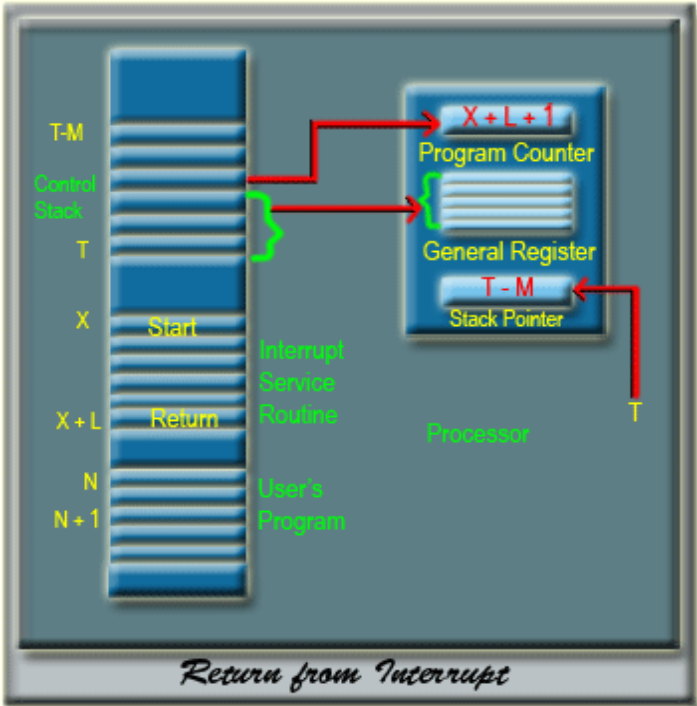

Figure 6.6: Return from interrupt

Once the program counter has been loaded, the processor proceeds to the next instruction cycle, which begins with an interrupt fetch. The control will transfer to interrupt handler routine for the current interrupt.

The following operations are performed at this point:

1. At the point, the program counter and PSW relating to the interrupted program have been saved on the system stack. In addition to that some more information must be saved related to the current processor state which includes the control of the processor registers, because these registers may be used by the interrupt handler. Typically, the interrupt handler will begin by saving the contents of all registers on stack.

2. The interrupt handles next processes the interrupt. This includes an examination of status information relating to the I/O operation or, other event that caused an interrupt.
3. When interrupt processing is complete, the saved register values are retrieved from the stack and restored to the registers.
4. The final act is to restore the PSW and program counter values from the stack. As a result, the next instruction to be executed will be from the previously interrupted program.

12.5.3 Design Issues for Interrupt

Two design issues arise in implementing interrupt I/O.

- There will almost invariably be multiple I/O modules, how does the processor determine which device issued the interrupt?
- If multiple interrupts have occurred how the processor does decide which one to process?

12.5.4 Device Identification

Four general categories of techniques are in common use:

- Multiple interrupt lines
- Software poll
- Daisy chain (hardware poll, vectored)
- Bus arbitration (vectored)

12.5.4.1 Multiple Interrupts Lines

The most straight forward approach is to provide multiple interrupt lines between the processor and the I/O modules. It is impractical to dedicate more than a few bus lines or processor pins to interrupt lines. Thus, though multiple interrupt lines are used, it is most

likely that each line will have multiple I/O modules attached to it. Thus, one of the other three techniques must be used on each line.

12.5.4.2 Software Poll

When the processor detects an interrupt, it branches to an interrupt service routine whose job is to poll each I/O module to determine which module caused the interrupt.

The poll could be implemented with the help of a separate command line (e.g. TEST I/O). In this case, the processor raises TEST I/O and place the address of a particular I/O module on the address lines. The I/O module responds positively if it set the interrupt.

Alternatively, each I/O module could contain an addressable status register. The processor then reads the status register of each I/O module to identify the interrupting module.

Once the correct module is identified, the processor branches to a device service routine specific to that device.

The main disadvantage of software poll is that it is time consuming. Processor has to check the status of each I/O module and in the worst case it is equal to the number of I/O modules.

12.5.4.3 Daisy Chain

In this method for interrupts all I/O modules share a common interrupt request lines. However, the interrupt acknowledge line is connected in a daisy chain fashion. When the processor senses an interrupt, it sends out an interrupt acknowledgement.

The interrupt acknowledge signal propagates through a series of I/O module until it gets to a requesting module.

The requesting module typically responds by placing a word on the data lines. This word is referred to as a vector and is either the address of the I/O module or some other unique identification.

In either case, the processor uses the vector as a pointer to the appropriate device service routine. This avoids the need to execute a general interrupt service routine first. This technique is referred to as a vectored interrupt. The daisy chain arrangement is shown in the Figure 6.7.

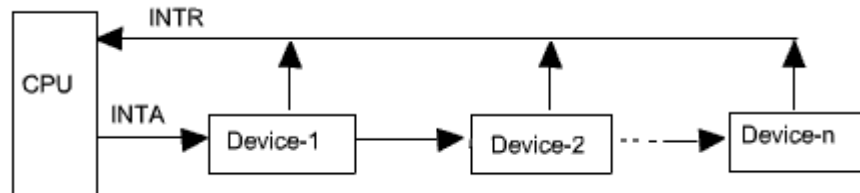

Figure 6.7: Daisy chain arrangement

12.5.4.4 Bus Arbitration

In bus arbitration method, an I/O module must first gain control of the bus before it can raise the interrupt request line. Thus, only one module can raise the interrupt line at a time. When the processor detects the interrupt, it responds on the interrupt acknowledge line. The requesting module then places its vector on the data line.

12.5.5 Handling multiple interrupts

There are several techniques to identify the requesting I/O module. These techniques also provide a way of assigning priorities when more than one device is requesting interrupt service. With multiple lines, the processor just picks the interrupt line with highest priority. During the processor design phase itself priorities may be assigned to each interrupt line. With software polling, the order in which modules are polled determines their priority.

In case of daisy chain configuration, the priority of a module is determined by the position of the module in the daisy chain. The module nearer to the processor in the chain has got higher priority, because this is the first module to receive the acknowledge signal that is generated by the processor.

In case of bus arbitration method, more than one module may need control of the bus. Since only one module at a time can successfully transmit over the bus, some method of arbitration is needed. The various methods can be classified into two group – centralized and distributed.

In a centralized scheme, a single hardware device, referred to as a bus controller or arbiter is responsible for allocating time on the bus. The device may be a separate module or part of the processor.

In distributed scheme, there is no central controller. Rather, each module contains access control logic and the modules act together to share the bus.

It is also possible to combine different device identification techniques to identify the devices and to set the priorities of the devices. As for example multiple interrupt lines and daisy chain technologies can be combined together to give access for more devices.

In one interrupt line, more than one device can be connected in daisy chain fashion. The High priorities devices should be connected to the interrupt lines that has got higher priority. A possible arrangement is shown in the Figure 6.8.

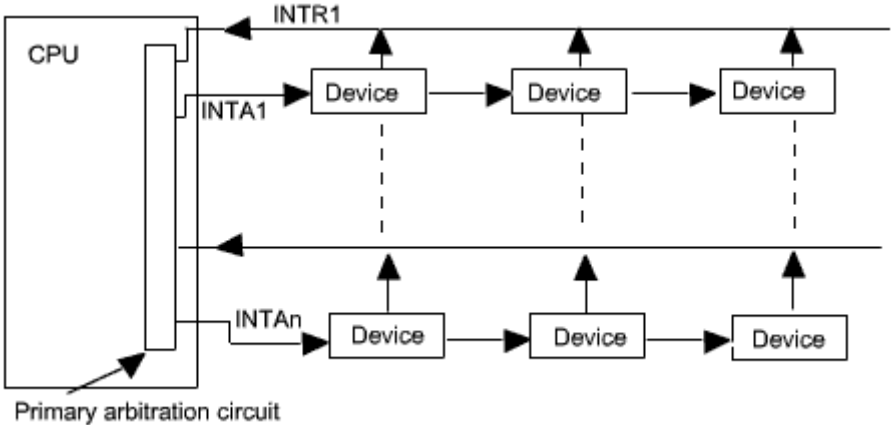

Figure 6.8: Possible arrangement to handle multiple interrupt

12.5.6 Interrupt Nesting

The arrival of an interrupt request from an external device causes the processor to suspend the execution of one program and starts the execution of another. The execution of this another program is nothing but the interrupt service routine for that specified device.

Interrupt may arrive at any time. So during the execution of an interrupt service routine, another interrupt may arrive. This kind of interrupts are known as nesting of interrupt.

Whether interrupt nesting is allowed or not? This is a design issue. Generally nesting of interrupt is allowed, but with some restrictions. The common notion is that a high priority device may interrupt a low priority device, but not the vice-versa.

To accommodate such type of restrictions, all computer provide the programmer with the ability to enable and disable such interruptions at various time during program execution. The processor provides some instructions to enable the interrupt and disable the interrupt. If interrupt is disabled, the CPU will not respond to any interrupt signal.

On the other hand, when multiple lines are used for interrupt and priorities are assigned to these lines, then the interrupt received in a low priority line will not be served if an interrupt routine is in execution for a high priority device. After completion of the interrupt service routine of high priority devices, processor will respond to the interrupt request of low priority devices

12.6 Direct Memory Access

We have discussed the data transfer between the processor and I/O devices. We have discussed two different approaches namely programmed I/O and Interrupt-driven I/O. Both the methods require the active intervention of the processor to transfer data between memory and the I/O module, and any data transfer must transverse a path through the processor. Thus, both these forms of I/O suffer from two inherent drawbacks.

The I/O transfer rate is limited by the speed with which the processor can test and service a device. The processor is tied up in managing an I/O transfer; a number of instructions must be executed for each I/O transfer.

To transfer large block of data at high speed, a special control unit may be provided to allow transfer of a block of data directly between an external device and the main memory, without continuous intervention by the processor. This approach is called direct memory access or DMA.

DMA transfers are performed by a control circuit associated with the I/O device and this circuit is referred as DMA controller. The DMA controller allows direct data transfer between the device and the main memory without involving the processor.

To transfer data between memory and I/O devices, DMA controller takes over the control of the system from the processor and transfer of data take place over the system bus. For this purpose, the DMA controller must use the bus only when the processor does not need it, or it must force the processor to suspend operation temporarily. The later technique is more common and is referred to as cycle stealing, because the DMA module in effect steals a bus cycle. The typical block diagram of a DMA controller is shown in the Figure 6.9.

When the processor wishes to read or write a block of data, it issues a command to the DMA module, by sending to the DMA module the following information.

- Whether a read or write is requested, using the read or write control line between the processor and the DMA module.
- The address of the I/O device involved, communicated on the data lines.
- The starting location in the memory to read from or write to, communicated on data lines and stored by the DMA module in its address register.
- The number of words to be read or written again communicated via the data lines and stored in the data count register.

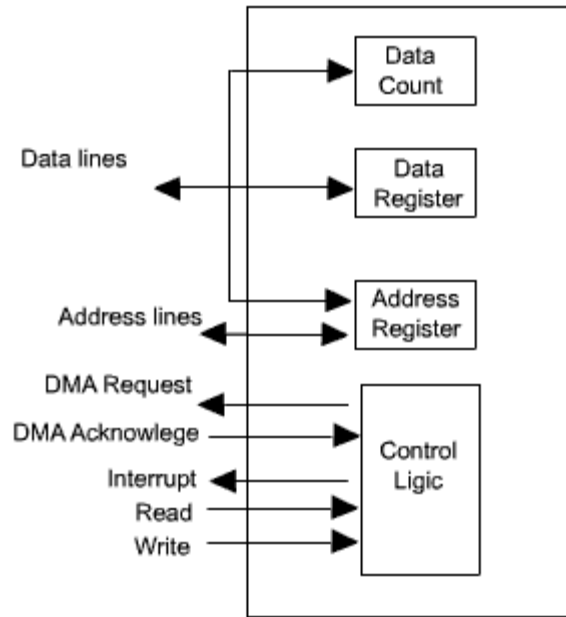

Figure 6.9: Typical DMA block diagram

The processor then continues with other works. It has delegated this I/O operation to the DMA module.

The DMA module checks the status of the I/O device whose address is communicated to DMA controller by the processor. If the specified I/O device is ready for data transfer, then DMA module generates the DMA request to the processor. Then the processor indicates the release of the system bus through DMA acknowledge.

The DMA module transfers the entire block of data, one word at a time, directly to or from memory, without going through the processor.

When the transfer is completed, the DMA module sends an interrupt signal to the processor. After receiving the interrupt signal, processor takes over the system bus. Thus, the processor is involved only at the beginning and end of the transfer. During that time the processor is suspended.

It is not required to complete the current instruction to suspend the processor. The processor may be suspended just after the completion of the current bus cycle. On the other hand, the processor can be suspended just before the need of the system bus by the processor, because DMA controller is going to use the system bus, it will not use the processor. The point where in the instruction cycle the processor may be suspended shown in the Figure 6.10.

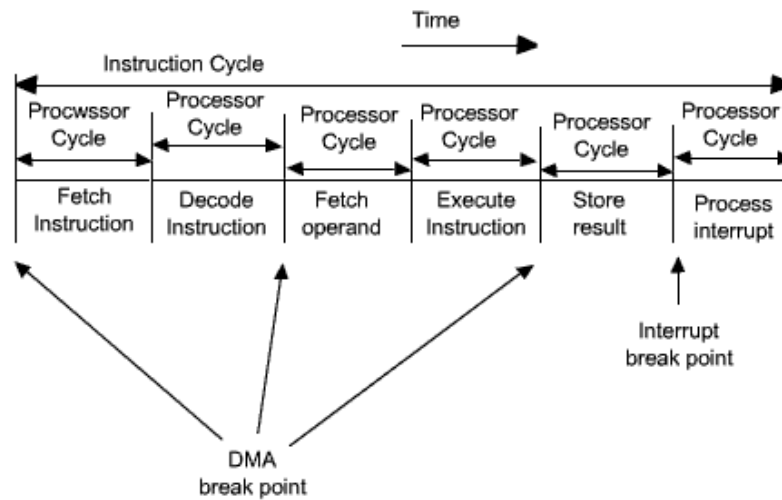

Figure 6.10: DMA break point

When the processor is suspended, then the DMA module transfer one word and return control to the processor.

Note that, this is not an interrupt, the processor does not save a context and do something else. Rather, the processor pauses for one bus cycle.

During that time processor may perform some other task which does not involve the system bus. In the worst situation processor will wait for some time, till the DMA releases the bus.

The net effect is that the processor will go slow. But the net effect is the enhancement of performance, because for a multiple word I/O transfer, DMA is far more efficient than interrupt driven or programmed I/O.

The DMA mechanism can be configured in different ways. The most common amongst them are:

- Single bus, detached DMA - I/O configuration.
- Single bus, Integrated DMA - I/O configuration.
- Using separate I/O bus.

12.6.1 Single bus, detached DMA - I/O configuration

In this organization all modules share the same system bus. The DMA module here acts as a surrogate processor. This method uses programmed I/O to exchange data between memory and an I/O module through the DMA module.

For each transfer it uses the bus twice. The first one is when transferring the data between I/O and DMA and the second one is when transferring the data between DMA and memory. Since the bus is used twice while transferring data, so the bus will be suspended twice. The transfer consumes two bus cycle. The interconnection organization is shown in the Figure 6.11.

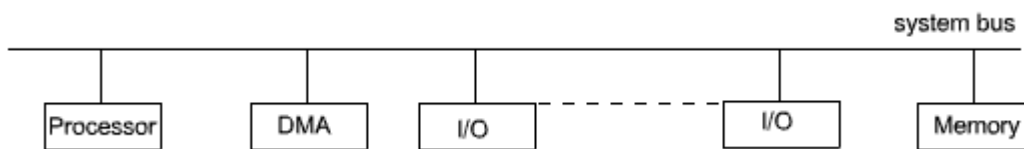

Figure 6.11: Single bus arrangement for DMA transfer

12.6.2 Single bus, Integrated DMA - I/O configuration

By integrating the DMA and I/O function the number of required bus cycle can be reduced. In this configuration, the DMA module and one or more I/O modules are integrated together in such a way that the system bus is not involved. In this case DMA logic may actually be a part of an I/O module, or it may be a separate module that controls one or more I/O modules.

The DMA module, processor and the memory module are connected through the system bus. In this configuration each transfer will use the system bus only once and so the processor is suspended only once.

The system bus is not involved when transferring data between DMA and I/O device, so processor is not suspended. Processor is suspended when data is transferred between DMA and memory. The configuration is shown in the Figure 6.12.

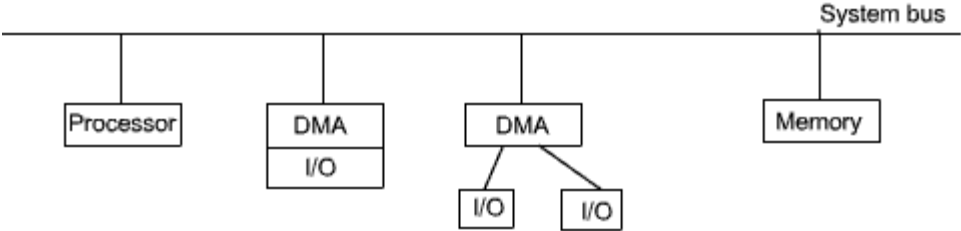

Figure 6.12: Single bus integrated DMA transfer

12.6.3 Using separate I/O bus

In this configuration the I/O modules are connected to the DMA through another I/O bus. In this case the DMA module is reduced to one. Transfer of data between I/O module and DMA module is carried out through this I/O bus. In this transfer, system bus is not in use and so it is not needed to suspend the processor.

There is another transfer phase between DMA module and memory. In this time system bus is needed for transfer and processor will be suspended for one bus cycle. The configuration is shown in the Figure 6.13.

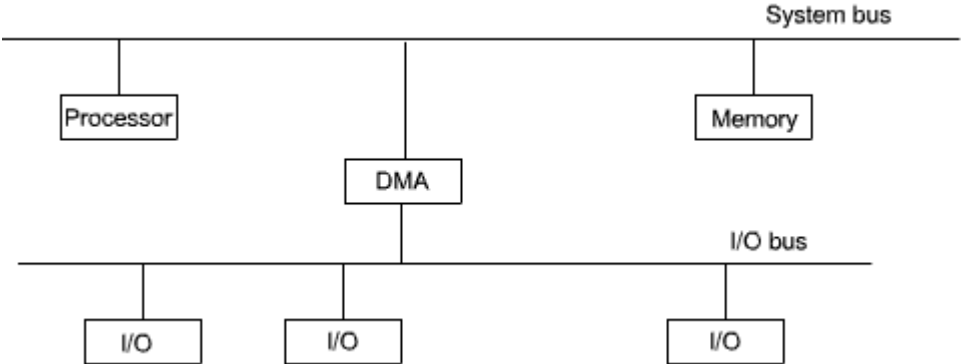

Figure 6.13: Separate I/O bus for DMA transfer



Check your progress II

1. To transfer large blocks of data at high speed, a special control unit may be provided between an external device and the main memory, without continuous intervention by the processor. This approach is called _____.
2. Pre-Emption of low priority Interrupt by another high priority interrupt is known as _____.
3. _____ is the process by which the next device to become the bus master is selected and bus mastership is transferred to it.
4. DMA transfers are performed by a control circuit associated with the I/O device and this circuit is referred as _____ .
5. In _____ all I/O modules share a common interrupt request lines.

12.7 Summary

1. The computer system's input/output (I/O) architecture is its interface to the outside world.
2. The internal resources, such as main memory and the system bus, must be shared among a number of activities, including data I/O.
3. The I/O function includes a control and timing requirement to co-ordinate the flow of traffic between internal resources and external devices.
4. The data buffering is required due to the mismatch of the speed of CPU, memory and other peripheral devices.
5. I/O module also perform error detection and for subsequently reporting error to the processor.
6. With programmed I/O, the processor executes a program that gives its direct control of the I/O operation, including sensing device status, sending a read or write command, and transferring the data.

7. With interrupt driven I/O, the processor issues an I/O command, continues to execute other instructions, and is interrupted by the I/O module when the I/O module completes its work.
8. In Direct Memory Access (DMA), the I/O module and main memory exchange data directly without processor involvement.
9. Memory-mapped I/O subsystems and I/O-mapped subsystems both require the CPU to move data between the peripheral device and main memory.
10. The arrival of an interrupt request from an external device causes the processor to suspend the execution of one program and starts the execution of another.
11. The DMA controller allows direct data transfer between the device and the main memory without involving the processor.

12.8 Model Questions

1. What are the functions of an I/O module?
2. Briefly explain the techniques for performing I/O.
3. What are the differences between memory mapped I/O and isolated I/O?
4. Why we use an I/O module to connect the peripheral devices to the CPU?
5. When a device interrupt occurs, how does the processor determine which device issued the interrupt?
6. How an interrupt mechanism works- explain briefly?
7. Explain the concept of daisy chain mechanism for device identification.
8. What are the advantages of using DMA?
9. Explain the DMA module and its function.



Answers to Check your progress I

1. Peripherals
2. Isolated I/O
3. Memory mapped I/O



Answers to Check your progress II

1. direct memory access (DMA)
2. Interrupt nesting
3. Arbitration
4. DMA controller
5. daisy chaining

INPUT/OUTPUT DEVICE CONNECTION

13.0 Learning Objectives

After completing this unit, the learner shall be able to:

- Explain the purpose of using a common bus;
- Categorize the common busses into various types;
- Explain various schemes that exist for handling the timing of data transfer over a bus;
- Know the limitations of simple design of device interface by synchronous bus;
- Differentiate between synchronous and asynchronous bus;
- Know various types of external memory devices;
- Explain the functioning of Magnetic Disks;
- Evaluate Disk Performance Parameters;
- Calculate transfer time and average access time of a magnetic disk;
- Define Redundant Arrays of Independent Disks (RAID) and RAID levels;

13.1 Buses

The processor, main memory, and I/O devices can be interconnected through common data communication lines which are termed as common bus. The primary function of a common bus is to provide a communication path between the devices for the transfer of data. The bus includes the control lines needed to support interrupts and arbitration. The bus lines used for transferring data may be grouped into three categories:

- data,
- address
- control lines.

A single R/\bar{W} line is used to indicate Read or Write operation. When several sizes are possible like byte, word, or long word, control signals are required to indicate the size of data. The bus control signal also carries timing information to specify the times at which the processor and the I/O devices may place data on the bus or receive data from the bus.

There are several schemes exist for handling the timing of data transfer over a bus. These can be broadly classified as

- Synchronous bus
- Asynchronous bus

13.1.1 Synchronous Bus

In a synchronous bus, all the devices are synchronized by a common clock, so all devices derive timing information from a common clock line of the bus. A clock pulse on this common clock line defines equal time intervals. In the simplest form of a synchronous bus, each of these clock pulse constitutes a bus cycle during which one data transfer can take place. The timing of an input transfer on a synchronous bus is shown in the Figure 7.1.

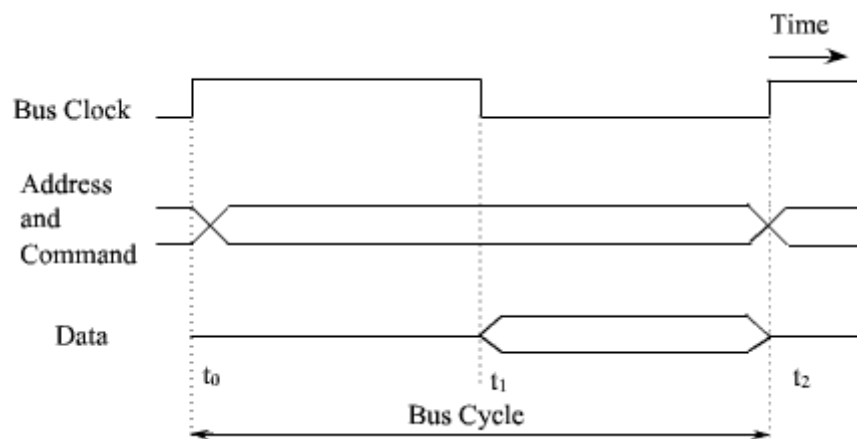

Figure 7.1: Timing of an input transfer on a synchronous bus

Let us consider the sequence of events during an input (read) operation. At time t_0 , the master places the device address on the address lines and sends an appropriate command (read in case of input) on the command lines. In any data transfer operation, one device plays the role of a master, which initiates data transfer by issuing read or write commands on the bus.

Normally, the processor acts as the master, but other device with DMA capability may also become bus master. The device addressed by the master is referred to as a slave or target device.

The command also indicates the length of the operand to be read, if necessary. The clock pulse width, $t_1 - t_0$, must be longer than the maximum propagation delay between two

devices connected to the bus. After decoding the information on address and control lines by slave, the slave device of that particular address responds at time t_1 . The addressed slave device places the required input data on the data line at time t_1 .

At the end of the clock cycle, at time t_2 , the master strobes the data on the data lines into its input buffer. The period $t_2 - t_1$ must be greater than the maximum propagation delay on the bus plus the setup time of the input buffer register of the master. A similar procedure is followed for an output operation. The master places the output data on the data lines when it transmits the address and command information. At time t_2 , the addressed device strobes the data lines and load the data into its data buffer.

13.1.1.1 Multiple Cycle Transfer

The simple design of device interface by synchronous bus has some limitations.

- A transfer has to be completed within one clock cycle. The clock period, must be long enough to accommodate the slowest device to interface. This forces all devices to operate at the speed of slowest device.
- The processor or the master has no way to determine whether the addressed device has actually responded. It simply assumes that the output data have been received by the device or the input data are available on the data lines.

To solve these problems, most buses incorporate control signals that represent a response from the device. These signals inform the master that the target device has recognized its address and it is ready to participate in the data transfer operation. They also adjust the duration of the data transfer period to suit the needs of the participating devices. A high frequency clock pulse is used so that a complete data transfer operation span over several clock cycles. The numbers of clock cycles involved can vary from device to device. An instance of this scheme is shown in the Figure 7.2.

In clock cycle 1, the master sends address and command on the bus requesting a read operation. The target device responded at clock cycle 3 by indicating that it is ready to participate in the data transfer by making the slave ready signal high. Then the target device places the data on the data line. The target device is a slower device and it needs

two clock cycle to transfer the information. After two clock cycle, that is at clock cycle 5, it pulls down the slave ready signal down. When the slave ready signal goes down, the master strobbs the data from the data bus into its input buffer. If the addressed device does not respond at all, the master waits for some predefined maximum number of clock cycles, then aborts the operation.

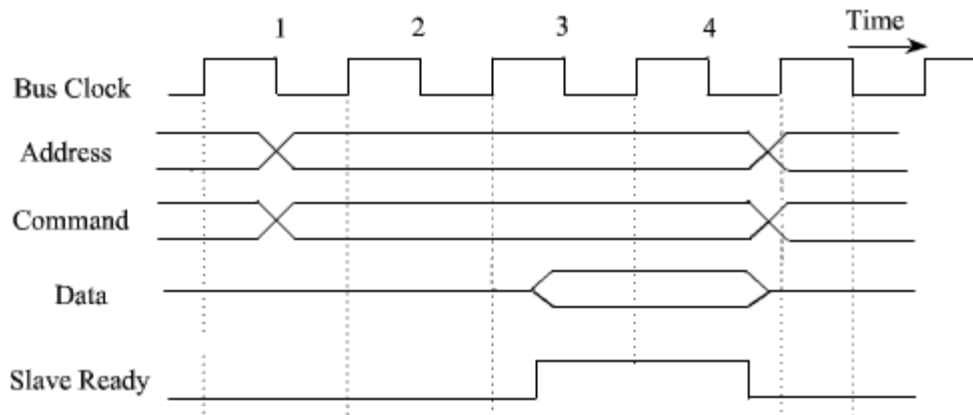

Figure 7.2: An input transfer using multiple clock cycle

13.1.2 Asynchronous Bus

In asynchronous mode of transfer, a handshake signal is used between master and slave.

- In asynchronous bus, there is no common clock, and the common clock signal is replaced by two timing control signals: master-ready and slave-ready.
- Master-ready signal is assured by the master to indicate that it is ready for a transaction, and slave-ready signal is a response from the slave.

The handshaking protocol proceeds as follows:

- The master places the address and command information on the bus. Then it indicates to all devices that it has done so by activating the master-ready signal.
- This causes all devices on the bus to decode the address.
- The selected target device performs the required operation and inform the processor (or master) by activating the slave-ready line.

- The master waits for slave-ready to become asserted before it removes its signals from the bus.
- In case of a read operation, it also strobbs the data into its input buffer.

The timing of an input data transfer using the handshake scheme is shown in the Figure 7.3.

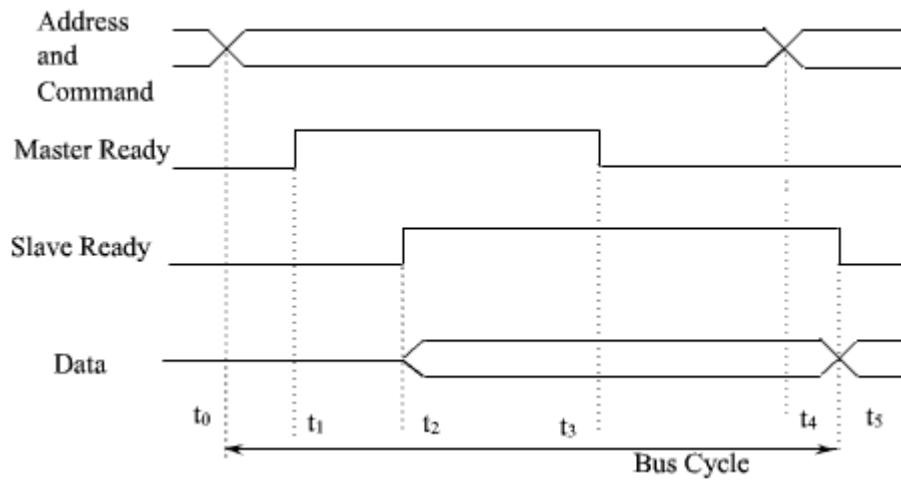

Figure 7.3: Handshake control of data transfer during an input operation

The timing of an output operation using handshaking scheme is shown in the Figure 7.4.

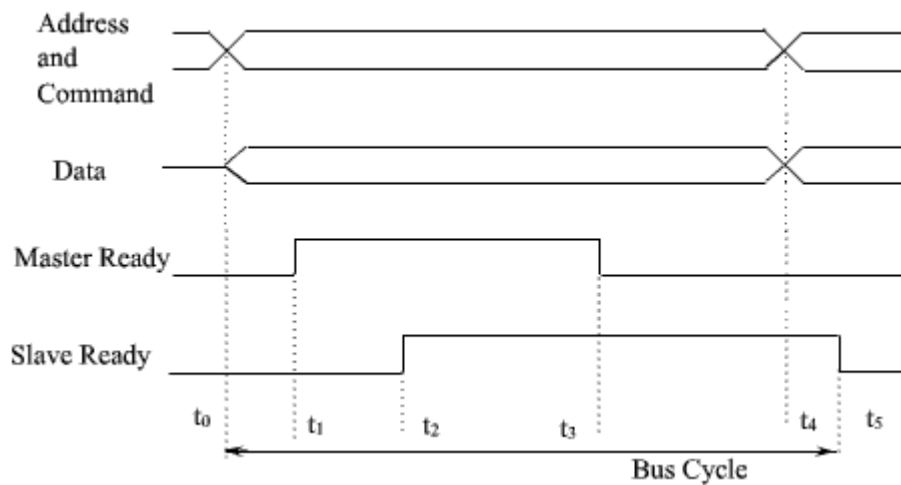



Figure 7.4: Handshake control of data transfer during an output operation



Check your progress I

1. A _____ is a subsystem that is used to connect computer components and transfer data between them.
2. In a _____ bus, all the devices are synchronized by a common clock, so all devices derive timing information from a common clock line of the bus.
3. In _____ bus, there is no common clock, and the common clock signal is replaced by two timing control signals: master-ready and slave-ready.

13.2 External Memory

Main memory is taking an important role in the working of computer. We have seen that computer works on Von-Neuman stored program principle. We have to keep the information in main memory and CPU access the information from main memory.

The main memory is made up of semiconductor device and by nature it is volatile. For permanent storage of information, we need some non-volatile memory. The memory devices need to store information permanently are termed as external memory. While working, the information will be transferred from external memory to main memory. The devices need to store information permanently are either magnetic or optical devices.\

<p><u>Magnetic Devices:</u></p> <ul style="list-style-type: none">■ Magnetic disk (Hard disk)■ Floppy disk■ Magnetic tape	<p><u>Optical Devices:</u></p> <ul style="list-style-type: none">■ CD- ROM■ CD-Recordable(CD –R)■ CD-R/W■ DVD
---	---

13.2.1 Magnetic Disk

A disk is a circular platter constructed of metal or of plastic coated with a magnetizable material. Data are recorded on and later retrieved from the disk via a conducting coil named the head. During a read or write operation, the head is stationary while the platter rotates beneath it.

The write mechanism is based on the fact that electricity flowing through a coil produces a magnetic field. Pulses are sent to the head, and magnetic patterns are recorded on the surface below. The pattern depends on the positive or negative currents. The direction of current depends on the information stored, i.e., positive current depends on the information '1' and negative current for information '0'.

The read mechanism is based on the fact that a magnetic field moving relative to a coil produces an electric current in the coil. When the surface of the disk passes under the head, it generates a current of the same polarity as the one already recorded. Read/ Write head detail is shown in the Figure 7.5.

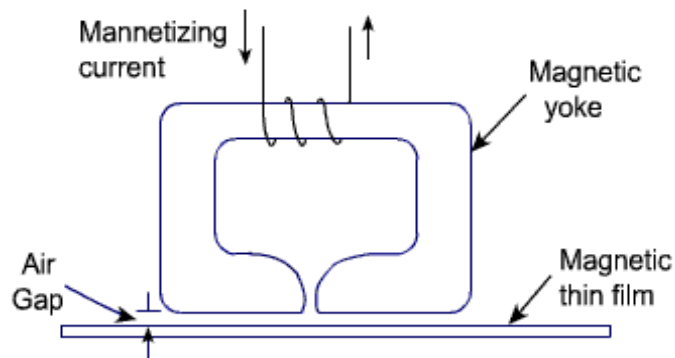

Figure 7.5: Read / Write details

The head is a relatively small device capable of reading from or writing to a portion of the platter rotating beneath it. The data on the disk are organized in a concentric set of rings, called track. Each track has the same width as the head. Adjacent tracks are separated by gaps. This prevents error due to misalignment of the head or interference of magnetic

fields. For simplifying the control circuitry, the same number of bits are stored on each track. Thus, the density, in bits per linear inch, increases in moving from the outermost track to the innermost track. Data are transferred to and from the disk in blocks. Usually, the block is smaller than the capacity of the track. Accordingly, data are stored in block-size regions known as sector. A typical disk layout is shown in the Figure 7.6.

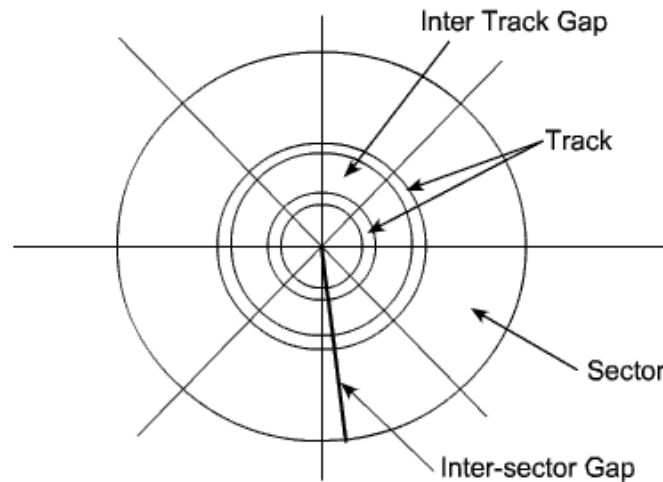

Figure 7.6: Disk Data Layout

To avoid, imposition unreasonable precision requirements on the system, adjacent tracks (sectors) are separated by intratrack (intersector) gaps.

Since data density in the outermost track is less and data density is more in inner tracks so there is wastage of space on outer tracks. To increase the capacity, the concept of zone is used instead of sectors. Each track is divided in zone of equal length and fix amount of data is stored in each zone. So, the number of zones are less in innermost track and number of zones are more in the outermost track. Therefore, a greater number of bits are stored in outermost track. The disk capacity is increasing due to the use of zone, but the complexity of control circuitry is also more. The concept of sector and zone of a track is shown in the Figure 7.7.

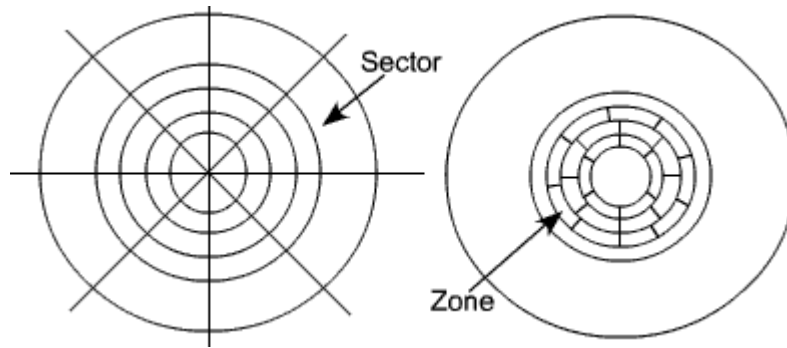

Figure 7.7: Sector and zone of a disk track

13.2.1.1 Physical characteristics of disk

- The head may be either fixed or movable with respect to the radial direction of the platter.
- In a fixed-head disk, there is one read-write head per track. All of the heads are mounted on a rigid arm that extends across all tracks.
- In a movable-head disk, there is only one read-write head. Again the head is mounted on an arm. Because the head must be able to be positioned above any track, the arm can be extended or retracted for this purpose. The fixed head and movable head is shown in the Figure 7.8.
- The disk itself is mounted in a disk drive, which consists of the arm, the shaft that rotates the disk, and the electronic circuitry needed for input and output the binary data and to control the mechanism.
- A non-removable disk is permanently mounted on the disk drive. A removable disk can be removed and replaced with another disk.
- For most disks, the magnetizable coating is applied to both sides of the platters, which is then referred to as double sided. If the magnetizable coating is applied to one side only, then it is termed as single sided disk.

Some disk drives accommodate multiple platters stacked vertically above one another. Multiple arms are provided for read write head. The platters come as a unit known as a disk pack. The physical organization of multiple platter disk is shown in the figure 7.9.

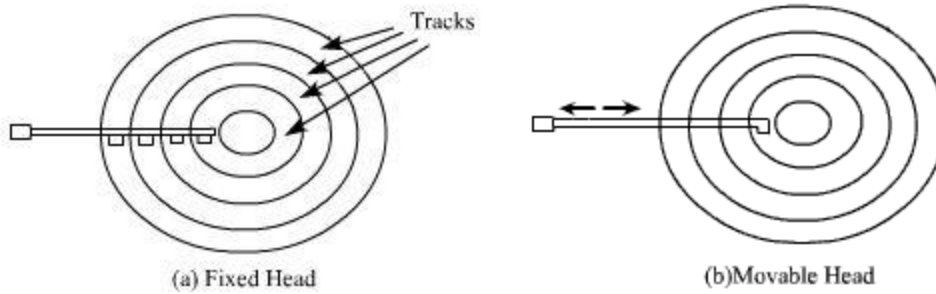

Figure 7.8: Fixed and Movable head disk

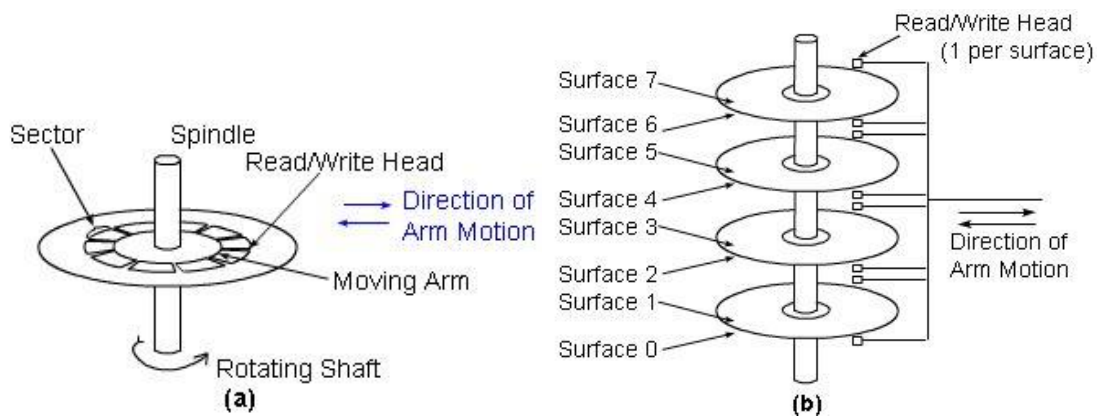

Figure 7.9: Multiple platter disk

13.2.1.2 Organization and accessing of data on a disk

The organization of data on a disk and its addressing format is shown in the Figure 7.10. Each surface is divided into concentric tracks and each track is divided into sectors. The set of corresponding tracks on all surfaces of a stack of disks forms a logical cylinder. Data bits are stored serially on each track. Data on disks are addressed by specifying the surface number, the track number, and the sector number. In most disk systems, read and write operations always start at sector boundaries. If the number of words to be written is smaller than that required to fill a sector, the disk controller repeats the last bit of data for the remaining of the sector. During read and write operation, it is required to specify the starting address of the sector from where the operation will start, that is the read/write head must be positioned to the correct track, sector and surface. Therefore, the address of the disk

contains track no., sector no., and surface no. If more than one drive is present, then drive number must also be specified.

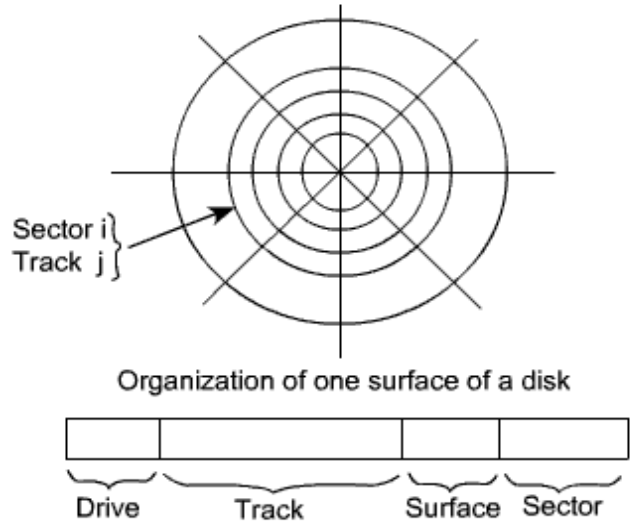
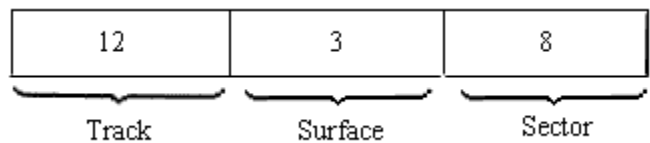

Figure 7.10: Organization of one surface of a disk

The format of the disk address word is shown in the figure. It contains the drive no, track no., surface no. and sector no.

By the surface no, it selects the correct surface.

To get the correct sector below the read/write head, the disk is rotated and bring the correct sector with the help of sector number. Once the correct sector, track and surface is decided, the read/write operation starts next.



Suppose that the disk system has 8 data recording surfaces with 4096 track per surface. Tracks are divided into 256 sectors. Then the format of disk address word is:

$$\begin{aligned} 8 \times 4096 \times 256 \times 512 &= 2^3 \times 2^{12} \times 2^8 \times 2^9 \\ &= 4 \text{ Giga byte (GB)} \end{aligned}$$

For moving head system, there are two components involved in the time delay between receiving an address and the beginning of the actual data transfer.

Seek Time: Seek time is the time required to move the read/write head to the proper track. This depends on the initial position of the head relative to the track specified in the address.

Rotational Delay: Rotational delay, also called the latency time is the amount of time that elapses after the head is positioned over the correct track until the starting position of the addressed sector comes under the Read/write head.

The read/write head will first be positioned to the correct track. In case of fixed head system, the correct head is selected by taking the track no. from the address. In case of movable head system, the head is moved so that it is positioned at the correct track.

13.2.1.3 Disk Operation

Communication between a disk and the main memory is done through DMA. The following information must be exchanged between the processor and the disk controller in order to specify a transfer.

Main memory address: The address of the first main memory location of the block of words involved in the transfer.

Disk address: The location of the sector containing the beginning of the the desired block of words.

Word count: The number of words in the block to be transferred.

The disk address format is:

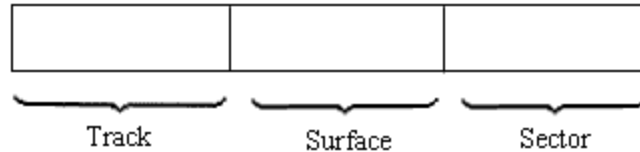

The word count may correspond to fewer or more bytes than that are contained in a sector. When the data block is longer than a track:

The disk address register is incremented as successive sectors are read or written. When one track is completed then the surface count is incremented by 1.

Thus, long data blocks are laid out on cylinder surfaces as opposed to being laid out on successive tracks of a single disk surface.

This is efficient for moving head systems, because successive sector areas of data storage on the disk can be accessed by electrically switching from one Read/Write head to the next rather than by mechanically moving the arm from track to track. The track-to-track movement is required only at cylinder-to-cylinder boundaries.

13.3 Disk Performance Parameter

When a disk drive is operating, the disk is rotating at constant speed. To read or write, the head must be positioned at the desired track and at the beginning of the desired sector on the track. Track selection involves moving the head in a movable-head system or electronically selecting one head on a fixed head system. On a movable-head system, the time taken to position the head at the track is known as seek time. Once the track is selected, the disk controller waits until the appropriate sector rotates to line up with the head. The time it takes to reach the beginning of the desired sector is known as rotational delay or rotational latency.

The sum of the seek time, (for movable head system) and the rotational delay is termed as access time of the disk, the time it takes to get into appropriate position (track & sector) to read or write.

Once the head is in position, the read or write operation is then performed as the sector moves under the head, and the data transfer takes place.

Seek Time: Seek time is the time required to move the disk arm to the required track. The seek time is approximated as

$$T_s = m \times n + s$$

where

T_s = estimated seek time

m = number of tracks traversed

n = constant that depends on the disk drive

s = startup time

Rotational Delay: Disk drive generally rotates at 3600 rpm, i.e., to make one revolution it takes around 16.7 ms. Thus on the average, the rotational delay will be 8.3 ms.

Transfer Time: The transfer time to or from the disk depends on the rotational speed of the disk and it is estimated as

$$T = \frac{b}{rN}$$

Where,

T = Transfer time

b = Number of bytes to be transferred.

n = Numbers of bytes on a track

r = Rotational speed, in revolution per second.

Thus, the total average access time can be expressed as

$$T_a = T_s + \frac{1}{2r} + \frac{b}{rN}$$

Where T_5 is the average seek time.

13.3.1 Issues with disks

Disks are potential bottleneck for system performances and storage system reliability. The disk access time is relatively higher than the time required to access data from main memory and performs CPU operation. Also, the disk drive contains some mechanical parts and it involves mechanical movement, so the failure rate is also high. The disk performance has been improving continuously, microprocessor performance has improved much more rapidly.

A disk array is an arrangement of several disk, organized to increase performance and improve reliability of the resulting storage system. Performance is increased through data striping. Reliability is improved through redundancy.

13.3.2 Data Striping

In data striping, the data is segmented in equal-size partitions distributed over multiple disks. The size of the partition is called the striping unit. The partitions are usually distributed using a round-robin algorithm:

if the disk array consists of D disks, then partition i is written in to disk $(i \bmod D)$.

Consider a striping unit equal to a disk block. In this case, I/O requests of the size of a disk block are processed by one disk in the array.

If many I/O requests of the size of a disk block are made, and the requested blocks reside on different disks, we can process all requests in parallel and thus reduce the average response time of an I/O request.

Since the striping unit are distributed over several disks in the disk array in round robin fashion, large I/O requests of the size of many continuous blocks involve all disks. We can process the request by all disks in parallel and thus increase the transfer rate.

Disk arrays that implement a combination of data striping and redundancy are called Redundant Arrays of Independent Disks (RAID).

13.3.3 Redundancy

While having more disks increases storage system performance, it also lower overall storage system reliability, because the probability of failure of a disk in disk array is increasing. Reliability of a disk array can be increased by storing redundant information. If a disk fails, the redundant information is used to reconstruct the data on the failed disk.

One design issue involves here - where to store the redundant information. There are two choices-either store the redundant information on a same number of check disks, or distribute the redundant information uniformly over all disk. In a RAID system, the disk array is partitioned into reliability group, where a reliability group consists of a set of data disks and a set of check disks. A common redundancy scheme is applied to each group.

13.3.4 RAID levels

13.3.4.1 RAID Level 0: Nonredundant

A RAID level 0 system is not a true member of the RAID family, because it does not include redundancy, that is, no redundant information is maintained.

It uses data striping to increase the I/O performance.

For RAID 0, the user and system data are distributed across all of the disk in the array, i.e. data are striped across the available disk.

If two different I/O requests are there for two different data block, there is a good probability that the requested blocks are in different disks. Thus, the two requests can be issued in parallel, reducing the I/O waiting time.

RAID level 0 is a low-cost solution, but the reliability is a problem since there is no redundant information to retrieve in case of disk failure.

RAID level 0 has the best write performance of all RAID levels, because there is no need of updation of redundant information.

13.3.4.2 RAID Level 1: Mirrored

RAID level 1 is the most expensive solution to achieve the redundancy. In this system, two identical copies of the data on two different disks are maintained. This type of redundancy is called mirroring.

Data striping is used here similar to RAID 0.

Every write of a disk block involves two write due to the mirror image of the disk blocks.

These writes may not be performed simultaneously, since a global system failure may occur while writing the blocks and then leave both copies in an inconsistent state. Therefore, write a block on a disk first and then write the other copy on the mirror disk.

A read of a block can be scheduled to the disk that has the smaller access time. Since we are maintaining the full redundant information, the disk for mirror copy may be less costly one to reduce the overall cost.

13.3.4.3 RAID Level 2

RAID levels 2 and 3 make use of a parallel access technique where all member disks participate in the execution of every I/O requests.

Data striping is used in RAID levels 2 and 3, but the size of strips are very small, often a small as a single byte or word.

With RAID 2, an error-correcting code is calculated across corresponding bits on each data disk, and the bits of the cods are stored in the corresponding bit positions on multiple parity disks.

RAID 2 requires fewer disks than RAID 1. The number of redundant disks is proportional to the log of the number of data disks. For error-correcting, it uses Hamming code.

On a single read, all disks are simultaneously accessed. The requested data and the associated error correcting code are delivered to the array controller. If there is a single bit error, the controller can recognize and correct the error instantly, so that read access time is not slowed down.

On a single write, all data disks and parity disks must be accessed for the write operation.

13.3.4.4 RAID level 3

RAID level 3 is organized in a similar fashion to RAID level 2. The difference is that RAID 3 requires only a single redundant disk.

RAID 3 allows parallel access, with data distributed in small strips.

Instead of an error correcting code, a simple parity bit is computed for the set of individual bits in the same position on all of the data disks.

In this event of drive failure, the parity drive is accessed and data is reconstructed from the remaining drives. Once the failed drive is replaced, the missing data can be restored on the new drive.

13.2.4.5 RAID level 4

RAID levels 4 through 6 make use of an independent access technique, where each member disk operates independently, so that separate I/O request can be satisfied in parallel.

Data stripings are used in this scheme also, but the data strips are relatively large for RAID levels 4 through 6.

With RAID 4, a bit-by-bit parity strip is calculated across corresponding strips on each data disks, and the parity bits are stored in the corresponding strip on the parity disk.

RAID 4 involves a write penalty when an I/O write request of small size is occurred. Each time a write occurs, update is required both in user data and the corresponding parity bits.

13.2.4.6 RAID level 5

RAID level 5 is similar to RAID 4, only the difference is that RAID 5 distributes the parity strips across all disks.

The distribution of parity strips across all drives avoids the potential I/O bottleneck.

13.3.4.7 RAID level 6

In RAID level 6, two different parity calculations are carried out and stored in separate blocks on different disks.

The advantage of RAID 6 is that it has got a high data availability, because the data can be regenerated even if two disk containing user data fails. It is possible due to the use of Reed-Solomon code for parity calculations. In RAID 6, there is a write penalty, because each write affects two parity blocks.



Check your progress II

1. Computer works on _____ stored program principle.
2. For permanent storage of information, we need some _____ memory.
3. _____ is the time required to move the read/write head to the proper track.
4. Data are recorded on and later retrieved from the disk via a conducting coil named the ____.
5. _____ is the amount of time that elapses after the head is positioned over the correct track until the starting position of the addressed sector comes under the Read/write head.
6. The size of the partition is called the _____ unit.

13.4 Summary

1. The primary function of a common bus is to provide a communication path between the devices for the transfer of data.
2. The bus lines used for transferring data may be grouped into three categories: data, address and control lines.
3. In the simplest form of a synchronous bus, each of these clock pulse constitutes a bus cycle during which one data transfer can take place.
4. In asynchronous mode of transfer, a handshake signal is used between master and slave.
5. The main memory is made up of semiconductor device and by nature it is volatile.
6. The memory devices need to store information permanently are termed as external memory.
7. A disk is a circular platter constructed of metal or of plastic coated with a magnetizable material.
8. Head is a relatively small device capable of reading from or writing to a portion of the platter rotating beneath it.
9. Each surface is divided into concentric tracks and each track is divided into sectors.
10. Data on disks are addressed by specifying the surface number, the track number, and the sector number.
11. On a movable-head system, the time taken to position the head at the track is known as seek time.
12. The time it takes to reach the beginning of the desired sector is known as rotational delay or rotational latency.
13. The sum of the seek time, (for movable head system) and the rotational delay is termed as access time of the disk, the time it takes to get into appropriate position (track & sector) to read or write.
14. Disk arrays that implement a combination of data striping and redundancy are called Redundant Arrays of Independent Disks (RAID).
15. Reliability of a disk array can be increased by storing redundant information.

16. In a RAID system, the disk array is partitioned into reliability group, where a reliability group consists of a set of data disks and a set of check disks.

13.5 Model Questions

1. What is synchronous bus and asynchronous bus?
2. What are the advantages of using multiple clocks in synchronous bus?
3. Explain the hand shake control of data transfer for asynchronous bus.
4. How are the data written onto a magnetic disk?
5. How are the data read from a magnetic disk?
6. Define track, cylinder and sector.
7. Define the term seek time, rotational delay and access time.
8. What is zone and sector of a disk and how they differ?
9. Explain the fixed head and movable head disk unit.



Answers to Check your progress I

1. bus
2. synchronous
3. asynchronous



Answers to Check your progress II

1. Von-Neuman
2. non volatile
3. Seek time
4. Head
5. Rotational delay
6. striping

REDUCED INSTRUCTION SET PROGRAMMING

14.0 Learning Objectives

After the successful completion this unit, the learner shall be able to:

- Know some of the major development in computer organization and architecture since 1950;
- Explain the characteristics of Reduced Instruction Set Computer (RISC) Architecture;
- Explain the characteristics of Complex Instruction Set Computer (CISC) Architecture;
- Differentiate between RISC and CISC architecture;
- Understand the design issues of RISC architecture;
- Explain the use of graph coloring problem for RISC compiler optimization;

14.1 Introduction

Since the development of the stored program computer around 1950, there are few innovations in the area of computer organization and architecture. Some of the major developments are:

- **The Family Concept:** Introduced by IBM with its system/360 in 1964 followed by DEC, with its PDP-8. The family concept decouples the architecture of a machine from its implementation. A set of computers are offered, with different price/performance characteristics, that present the same architecture to the user.
- **Microprogrammed Control Unit:** Suggested by Wilkes in 1951, and introduced by IBM on the S/360 line in 1964. Microprogramming eases the task of designing and implementing the control unit and provide support for the family concept.
- **Cache Memory:** First introduced commercially on IBM S/360 Model 85 in 1968. The insertion of this element into the memory hierarchy dramatically improves performance.
- **Pipelining:** A means of introducing parallelism into the essentially sequential nature of a machine instruction program. Examples are instruction pipelining and vector processing.
- **Multiple Processor:** This category covers a number of different organizations and objectives.

One of the most visible forms of evolution associated with computers is that of programming languages. Even more powerful and complex high-level programming languages have been developed by the researcher and industry people.

The computer designers intend to reduce this gap and include large instruction set, more addressing mode and various HLL statements implemented in hardware. As a result, the instruction set becomes complex. Such complex instruction sets are intended to-

- Ease the task of the compiler writer.
- Improve execution efficiency, because complex sequences of operations can be implemented in microcode.
- Provide support for even more complex and sophisticated HLLs.

To reduce the gap between HLL and the instruction set of computer architecture, the system becomes more and more complex and the resulted system is termed as Complex Instruction Set Computer (CISC). A number of studies have been done over the years to determine the characteristics and patterns of execution of machine instructions generated from HLL programs. The instruction execution characteristics involves the following aspects of computation:

- Operation Performed: These determine the functions to be performed by the processor and its interaction with memory.
- Operand Used: The types of operands and the frequency of their use determine the memory organization for storing them and the addressing modes for accessing them.
- Execution sequencing: This determines the control and pipeline organization.

14.1.1 Operations

A variety of studies have been made to analyze the behavior of HLL programs. It is observed that

- Assignment statements predominates, suggesting that the simple movement of data is of high importance.

- There is also a presence of conditional statements (IF, Loop, etc.). These statements are implemented in machine language with some sort of compare and branch instruction. This suggest that the sequence control mechanism of the instruction set is important.

A variety of studies have analyzed the behavior of high level language program. The Table 8.1 includes key results, measuring the appearance of various statement types during execution which is carried out by different researchers.

Table 8.1: Relative Dynamic Frequency of High-Level Language operation

Study Language Workload	[HUCK83]	[KNUTH71]	[PATT82]		[TANE78]
	Pacal Scientific	Fortran Student	Pascal System	C System	SAL System
Assign	74	67	45	38	42
Loop	4	3	5	3	4
Call	1	3	15	12	12
IF	20	11	29	43	36
GOTO	20	9	--	3	--
Other	--	7	6	1	

- [HUCK83] Huck, T; "Comparative analysis of computer architectures", Stanford University Technical Report, No.83-243.
- [KNUTH71] Knuth D; "An Empirical Study of FORTRAN programs ", Software practice and Experience, Vol. 1,1971. No.83-243
- [PATT82] Patterson, D and Sequin, C; "A VLSI RISC ", Computer, September 1982.
- [TANE78] Tanenbaum, A; "Implication of Structured Programming for machine architecture ", Communication of the ACM, March 1978.

These results are instructive to the machine instruction set designers, indicating which type of statements occur most often and therefore should be supported in an “optimal” fashion. From these studies one can observe that though a complex and sophisticated instruction set

is available in a machine architecture, common programmer may not use those instructions frequently.

14.1.2 Operands

Researches also studied the dynamic frequency of occurrence of classes of variables. The results showed that majority of references are single scalar variables. In addition references to arrays/structures required a previous reference to their index or pointer, which again is usually a local scalar. Thus, there is a predominance of references to scalars, and these are highly localized. It is also observed that operation on local variables is performed frequently and it requires a fast accessing of these operands. So, it suggests that a prime candidate for optimization is the mechanism for storing and accessing local scalar variables.

14.1.3 Procedure Call

The procedure calls and returns are an important aspect of HLL programs. Due to the concept of modular and functional programming, the call/return statements are becoming a predominate factor in HLL program.

It is known fact that call/return is a most time consuming and expensive statements. Because during call we have to restore the current state of the program which includes the contents of local variables that are present in general purpose registers. During return, we have to restore the original state of the program from where we start the procedure call.

Thus, it will be profitable to consider ways of implementing these operations efficiently. Two aspects are significant, the number of parameters and variables that a procedure deals with, and the depth of nesting.

14.1.4 Implications

A number of groups have looked at these results and have concluded that the attempt to make the instruction set architecture close to HLL is not the most effective design strategy.

Generalizing from the work of a number of researchers three element emerge in the computer architecture.

- First, use a large number of registers or use a compiler to optimize register usage. This is intended to optimize operand referencing.
- Second, careful attention needs to be paid to the design of instruction pipelines. Because of the high proportion of conditional branch and procedure call instructions, a straight forward instruction pipeline will be inefficient. This manifests itself as a high proportion of instructions that are prefetched but never executed.
- Third, a simplified (reduced) instruction set is indicated. It is observed that there is no point to design a complex instruction set which will lead to a complex architecture. Due to the fact, a most interesting and important processor architecture evolves which is termed as Reduced Instruction Set Computer (RISC) architecture.

Although RISC system have been defined and designed in a variety of ways by different groups, the key element shared by most designs are these:

- A large number of general-purpose registers, or the use of compiler technology to optimize register usage.
- A limited and simple instruction set.
- An emphasis on optimizing the instruction pipeline
- An analysis of the RSIC architecture begins into focus many of the important issues in computer organization and architecture.

The comparison of RISC and non-RISC systems is given in the Table 8.2.

Table 8.2: Characteristics of some CISCs, RISCs and Superscalar Processors

	Complex Instruction Set (CISC) Computer			Reduced Instruction Set (RISC) Computer		Superscalar		
	IBM 370/168	VAX 11/780	Intel 80486	SPARC	MIPS R4000	Power PC	Ultra SPARC	MIPS R10000
Characteristics								
Year Developed	1973	1978	1989	1987	1991	1993	1996	1996
Number of Instructions	208	303	235	69	94	225	--	--

Instruction Size (bytes)	2-6	2-57	1-11	4	4	4	4	4
Addressing modes	4	22	11	1	1	2	1	1
Number of general-purpose registers	16	16	8	40-520	32	32	40-520	32
Control Memory size (kbits)	420	480	246	--	--	--	--	--
Cache size (kbits)	64	64	8	32	128	16-32	32	64

14.2 Characteristics of Reduced Instruction Set Architecture

Although a variety of different approaches to reduce Instruction set architecture have been taken, certain characteristics are common to all of them:

- One instruction per cycle.
- Register-to-register operations.
- Simple addressing modes.
- Simple instruction formats.

14.2.1 One machine instruction per machine cycle

A machine cycle is defined to be the time it takes to fetch two operands from registers, perform an ALU operation, and store the result in a register.

With simple, one-cycle instructions there is little or no need of microcode, the machine instructions can be hardwired. Hardware implementation of control unit executes faster than the microprogrammed control, because it is not necessary to access a microprogram control store during instruction execution.

14.2.2 Register –to– register operations

With register–to–register operation, a simple LOAD and STORE operation is required to access the memory, because most of the operation are register–to–register. Generally, we do not have memory–to–memory and mixed register/memory operation.

14.2.3 Simple Addressing Modes

Almost all RISC instructions use simple register addressing. For memory access only, we may include some other addressing, such as displacement and PC-relative. Once the data are fetched inside the CPU, all instruction can be performed with simple register addressing.

14.2.4 Simple Instruction Format

Generally, in most of the RISC machine, only one or few formats are used. Instruction length is fixed and aligned on word boundaries. Field locations, especially the opcode, are fixed. With fixed fields, opcode decoding and register operand accessing can occur simultaneously. Simplified formats simplify the control unit.



Check your progress I

1. The insertion of _____ into the memory hierarchy dramatically improves performance.
2. _____ is the first company who defined RISC architecture.
3. How is memory accessed in the RISC architecture? (Chose the correct one)
 - A. Load and Store Instruction
 - B. Opcode Instruction
 - C. Memory Instruction
 - D. Bus Instruction

14.3 Design Issues of RISC

14.3.1 The use of a large register file

For fast execution of instructions, it is desirable of quick access to operands. There is large proportion of assignment statements in HLL programs, and many of these are of the simple form $A \leftarrow B$. Also, there are significant number of operand accesses per HLL Statement. Also, it is observed that most of the accesses are local scalars. To get a fast response, we must have an easy excess to these local scalars, and so the use of register storage is suggested.

Since registers are the fastest available storage devices, faster than both main memory and cache, so the uses of registers are preferable. The register file is physically small, and on the same chip as the ALU and Control Unit. A strategy is needed that will allow the most frequently accessed operands to be kept in registers and to minimize register-memory operations.

Two basic approaches are possible, one is based on software and the other on hardware.

- The software approach is to rely on the compiler to maximize register uses. The compiler will attempt to allocate registers to those variables that will be used the most in a given time period.
- The hardware approach is simply to use more registers so that more variables can be held in registers for longer period of time. In hardware approach, it uses the concept of register windows.

14.3.2 Register Window

The use of a large set of registers should decrease the need to access memory. The design task is to organize the registers in such a way that this goal is realized. Due to the use of the concept of modular programming, the present day programs are dominated by call/return statements. There are some local variables present in each function or procedure.

1. On every call, local variables must be saved from the registers into memory, so that the registers can be reused by the called program. Furthermore, the parameters must be passed.
2. On return, the variables of the parent program must be restored (loaded back into registers) and results must be passed back to the parent program.
3. There are also some global variables which are used by the module or procedure.

Thus, the variables that are used in a program can be categorized as follows:

- **Global variables** : which is visible to all the procedures.
- **Local variables** : which is local to a procedure and it can be accessed inside the procedure only.
- **Passed parameters** : which are passed to a subroutine from the calling program. So, these are visible to both, called and calling program.
- **Returned variable** : variable to transfer the results from called program to the calling program. These are also visible to both called and calling program.

From the studies it is observed that a typical procedure employs only a few passed parameters and local variables. Also, the depth of procedure activation remains within a relatively narrow range. To exploit these properties, multiple small sets of registers are used, each assigned to a different procedure.

A procedure call automatically switches the processor to use a different fixed size window of registers, rather than saving registers in memory. Windows for adjacent procedures are overlapped to allow parameter passing. The concept of overlapping register window is shown in the Figure 8.1.

At any time, only one window of registers is visible which corresponds to the currently executing procedure.

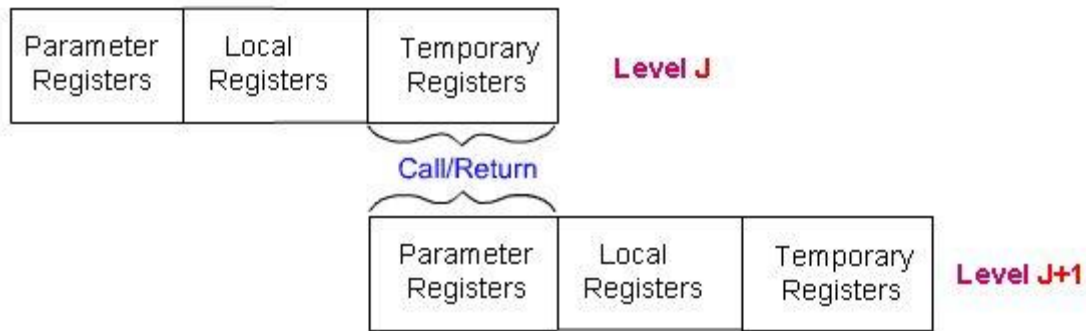

Figure 8.1: Overlapping register window

The register window is divided into three fixed-size areas.

- Parameter registers hold parameters passed down from the procedure that called the current procedure and hold results to be passed back up.
- Local registers are used for local variables.
- Temporary registers are used to exchange parameters and results with the next lower level (procedure called by current procedure).

The temporary registers at one level are physically the same as the parameter registers at the next lower level. This overlap permits parameter to be passed without the actual movement of data.

To handle any possible pattern of calls and returns, the number of register windows would have to be unbounded. But we have a limited number of registers, it is not possible to provide unlimited amount of registers. It is possible to hold the few most recent procedure activation in register windows.

Older activations must be saved in memory and later restored when the nesting depth decreases. It is observed that nesting depth is small in general.

The circular buffer of overlapping windows is shown in the Figure 8.2. The procedure call pattern is : A called B, B called C, C called D and D called E, with procedure E as active process. The current window pointer (CWP) points to the window of currently active

procedure. The saved window pointer identifies the window most recently saved in memory.

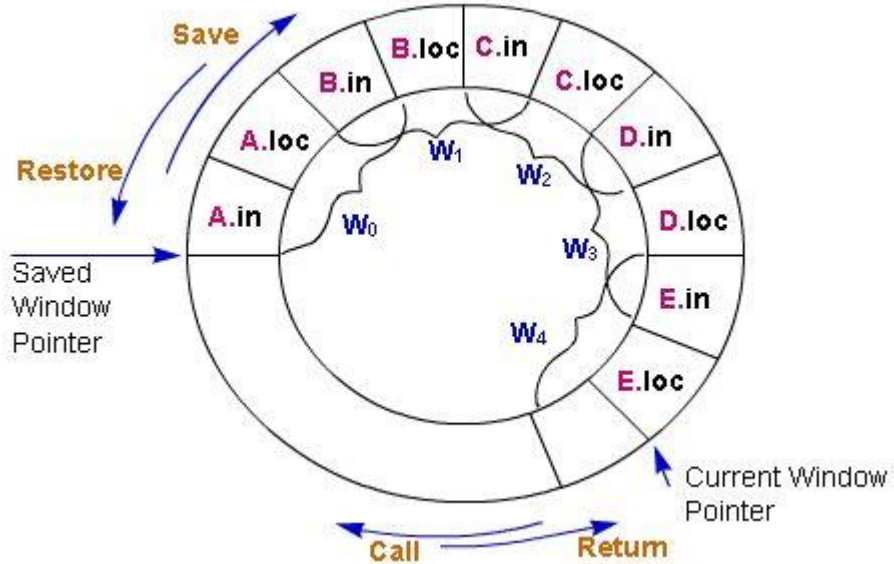

Figure 8.2: Circular buffer of overlapping windows

As the nesting depth of procedure calls increases, there may not be sufficient register to accommodate the new procedure. In this case, the information of oldest procedure is stored back into memory and the saved window pointer keep tracks of the most recently saved window.

It is clear that N-Window register file can hold only N-1 procedure activations. The value of N need not be very large, because in general, the depth of procedure activation is small. In case of recursive call, the depth of procedure call may increase. From survey, it is found that with 8 windows, a save or restore is needed on only 1% of the calls or returns.

14.3.3 Global Variables

The window scheme provides an efficient organization for storing local scalar variables in registers. Global variables are accessed by more than one procedure. Two solutions to access the global variables:

- Variables declared as global in an HLL can be assigned memory location by the compiler, and all machine instructions that reference these variables will use memory reference operands. This scheme is inefficient for frequently accessed global variables.
- An alternative is to incorporate a set of global registers in the processor. These registers would be fixed in number and available to all procedures. In this case, the compiler must decide which global variables should be assigned to registers.

14.3.4 Compiler based Register Optimization

A small number of registers (e.g. 16-32) is available on the target RISC machine and the concept of registers window cannot be used. In this case, optimized register usage is the responsibility of the compiler. A program written in a high-level language has no explicit references to registers. The objective of the compiler is to keep the operands for as many computations as possible in registers rather than main memory, and to minimize load and store operations. To optimize the use of registers, the approach taken is as follows:

- Each program quantity that is a candidate for residing in a register is assigned to a symbolic or virtual register.
- The compiler then maps the unlimited number of symbolic registers into a fixed number of real registers.
- Symbolic registers whose usage does not overlap can share the same real register.
- If in a particular portion of the program, there are more quantities to deal with than real registers, then some of the quantities are assigned to the memory location.

The task of optimization is to decide which quantities are to be assigned to registers at any given point of time in the program. The technique most commonly used in RISC compiler is known as graph coloring.

The graph coloring problem is as follows:

Given a graph consisting of nodes and edges, assign colors to nodes such that adjacent nodes have different colors, and do this in such a way as to minimize the number of different colors. This graph coloring problem is mapped to the register optimization problem of the compiler in the following way:

- The program is analyzed to build a register interference graph.
- The nodes of the graph are the symbolic registers.
- If two symbolic registers are “live” during the same program fragment, then they are joined by an edge to indicate interference.
- An attempt is then made to color the graph with n colors, where n is the number of registers.
- Nodes that cannot be colored are placed in memory.
- Load and store must be used to make space for the affected quantities when they are needed.

The part 'a' of Figure 8.3 shows a program with seven symbolic registers to be compiled in three actual registers. Part 'b' of Figure 8.3 shows the register interference graph. A possible coloring with three colors is shown. Only, a symbolic register E is left uncolored and must be dealt with load and store.

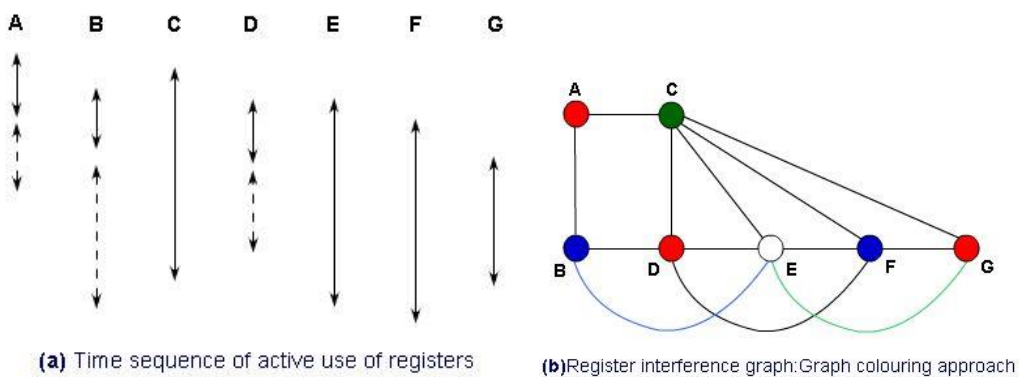

Figure 8.3

14.4 Large Register file versus cache

The Register file, organized into windows, acts as a small, fast buffer for holding a subset of all variables that are likely to be used the most heavily. From this point of view, the register file acts much like a cache memory.

The question therefore arises as to whether it would be simpler and better to use a cache and a small traditional register file instead of using a large register file. The Table 8.3 compares the characteristics of two approaches.

Table 8.3: The characteristics of the two approaches

	Large Register File	Cache
1.	All local scalars	Recently used local scalars.
2.	Individual variables	Blocks of memory.
3.	Compiler-assigned global variables	Recently used global variables.
4.	Save/Restore based on procedure nesting depth	Save/Restore based on cache replacement algorithm.
5.	Register addressing	Memory addressing.



Check your progress II

1. The technique most commonly used in RISC compiler is known as_____.
2. Which register of current procedure resemble physically similar to the parameter register of called procedure during register to register operation in an overlapping window of RISC Processors? (Chose the correct option)
 - A. Local Register
 - B. Temporary Register
 - C. Parameter Register
 - D. All of the Above

14.5 Summary

1. RISC is an abbreviation of Reduced Instruction Set Computer.
2. RISC processor has 'instruction sets' that are simple and have simple 'addressing modes'.
3. A RISC style instruction engages "one word" in memory.
4. Execution of the RISC instructions are faster and take one clock cycle per instruction.
5. Although the forerunners of RISC computers were seen in 1960. But, due to the popularity of CISC microprocessors which were implemented by the manufacturers in calculators, video games, stereos, etc.
6. RISC helps and supports few simple data types and synthesizes complex data types.
7. RISC utilizes simple addressing modes and fixed length instructions for pipelining.
8. RISC permits any register to use in any context.
9. The amount of work that a computer can perform is reduced by separating "LOAD" and "STORE" instructions.
10. RISC contains Large Number of Registers in order to prevent various number of interactions with memory.
11. In RISC, Pipelining is easy as the execution of all instructions will be done in a uniform interval of time i.e. one clock.
12. In RISC, more RAM is required to store assembly level instructions.
13. Reduced instructions need a smaller number of transistors in RISC.
14. RISC uses Harvard memory model means it is Harvard Architecture.
15. A compiler is used to perform the conversion operation means to convert a high-level language statement into the code of its form.
16. The CISC approach attempts to minimize the number of instructions per program, sacrificing the number of cycles per instruction.
17. Computers based on the CISC architecture are designed to decrease the memory cost.

14.6 Model Questions

1. What are the distinguishing characteristics of RISC organization?
2. Briefly explain the basic approaches used to minimize register-memory operations on RISC machines.
3. Give some reasons for shifting the paradigm from CISC to RISC.
4. Explain the concept of register window to handle the procedure calls.
5. If a circular register buffer is used to handle local variables for nested procedures, describe the approaches for handling global variables.
6. Explain the concept of graph coloring to optimize the register uses.
7. What are the differences of using large register file and cache memory?



Answers to Check your progress I

1. Cache memory
2. IBM
3. A



Answers to Check your progress II

1. graph coloring
2. B

PIPELINING PROCESSOR

15.0 Learning Objectives

After completing this unit, the learner shall be able to:

- Define pipelining;
- Explain the pipeline execution of fetch and execution cycle;
- Calculate the the cycle time of an Instruction pipeline;
- Calculate the speed up factor for the instruction pipeline compared to execution without the pipeline;
- Explain various approaches used for dealing with conditional branches;

15.1 Introduction to Pipeline Processor

It is observed that organization enhancements to the CPU can improve performance. We have already seen that use of multiple registers rather than a single accumulator, and use of cache memory improves the performance considerably. Another organizational approach, which is quite common, is instruction pipelining. Pipelining is a particularly effective way of organizing parallel activity in a computer system. The basic idea is very simple. It is frequently encountered in manufacturing plants, where pipelining is commonly known as an assembly line operation.

By laying the production process out in an assembly line, product at various stages can be worked on simultaneously. This process is also referred to as pipelining, because, as in a pipeline, new inputs are accepted at one end before previously accepted inputs appear as outputs at the other end.

To apply the concept of instruction execution in pipeline, it is required to break the instruction in different task. Each task will be executed in different processing elements of the CPU. As we know that there are two distinct phases of instruction execution: one is instruction fetch and the other one is instruction execution. Therefore, the processor executes a program by fetching and executing instructions, one after another.

Let F_i and E_i refer to the fetch and execute steps for instruction I_i . Execution of a program consists of a sequence of fetch and execute steps is shown in the Figure 9.1.

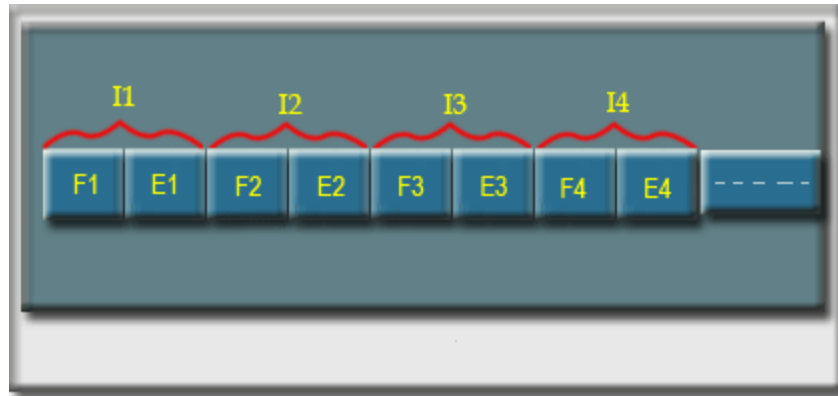

Figure 9.1: Sequential Execution

Now consider a CPU that has two separate hardware units, one for fetching instructions and another for executing them. The instruction fetch by the fetch unit is stored in an intermediate storage buffer B_1 . The results of execution are stored in the destination location specified by the instruction. For simplicity it is assumed that fetch and execute steps of any instruction can be completed in one clock cycle.

The operation of the computer proceeds as follows:

- In the first clock cycle, the fetch unit fetches an instruction (instruction I_1 , step F_2) and stored it in B_1 buffer at the end of the clock cycle.
- In the second clock cycle, the instruction fetch unit proceeds with the fetch operation for instruction I_2 (step F_2).
- Meanwhile, the execution unit performs the operation specified by instruction I_1 which is already fetched and available in the buffer B_1 (step E_1).
- By the end of the second clock cycle, the execution of the instruction I_1 is completed and instruction I_2 is available.
- Instruction I_2 is stored in buffer B_1 replacing I_1 , which is no longer needed.
- Step E_2 is performed by the execution unit during the third clock cycle, while instruction I_3 is being fetched by the fetch unit.
- Both the fetch and execute units are kept busy all the time and one instruction is completed after each clock cycle except the first clock cycle.
- If a long sequence of instructions is executed, the completion rate of instruction execution will be twice that achievable by the sequential operation with only one unit that performs both fetch and execute.

Basic idea of instruction pipelining with hardware organization is shown in the Figure 9.2.

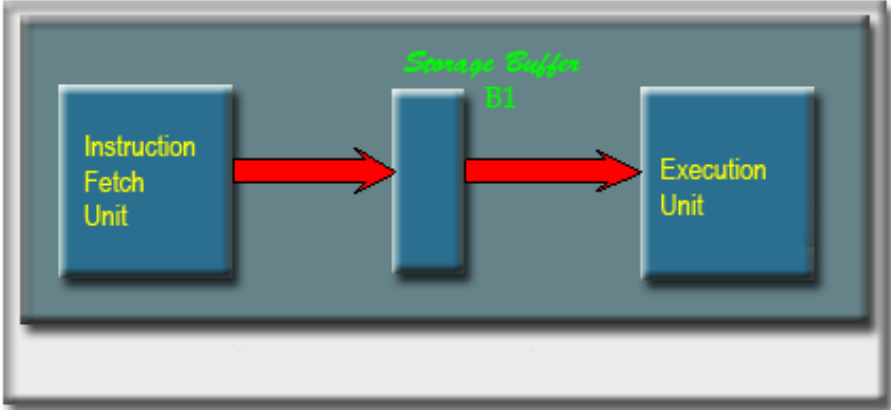

Figure 9.2: Hardware Organization

The pipeline execution of fetch and execution cycle is shown in the Figure 9.3.

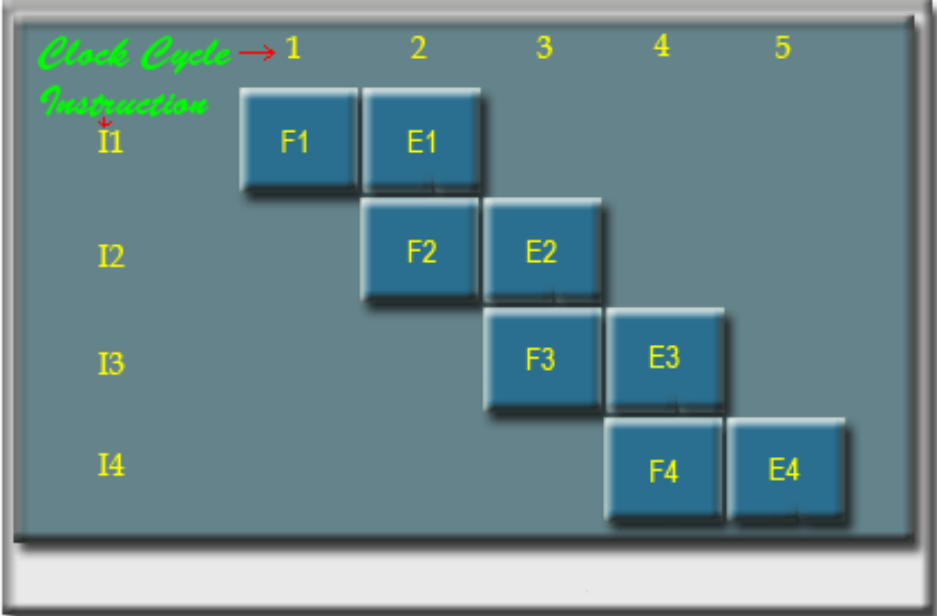

Figure 9.3: Pipeline Execution

he processing of an instruction need not be divided into only two steps. To gain further speed up, the pipeline must have more stages. Let us consider the following decomposition of the instruction execution:

- **Fetch Instruction (FI):** Read the next expected instruction into a buffer.
- **Decode Instruction ((DI):** Determine the opcode and the operand specifiers.
- **Calculate Operand (CO):** calculate the effective address of each source operand.
- **Fetch Operands(FO):** Fetch each operand from memory.
- **Execute Instruction (EI):** Perform the indicated operation.
- **Write Operand(WO):** Store the result in memory.

There will be six different stages for these six subtasks. For the sake of simplicity, let us assume the equal duration to perform all the subtasks. It the six stages are not of equal duration, there will be some waiting involved at various pipeline stages. The timing diagram for the execution of instruction in pipeline fashion is shown in the Figure 9.4.

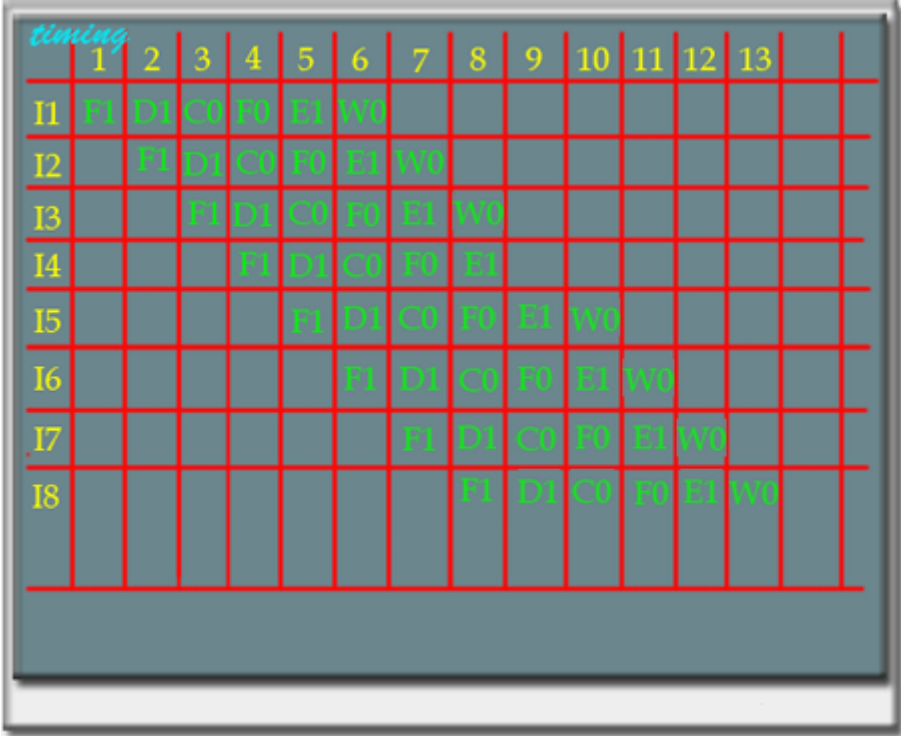

Figure 9.4: Timing sequence in pipeline execution

From this timing diagram it is clear that the total execution time of 8 instructions in this 6 stages pipeline is 13-time unit. The first instruction gets completed after 6 time unit, and thereafter in each time unit it completes one instruction. Without pipeline, the total time required to complete 8 instructions would have been 48 (6 X 8) time unit. Therefore, there is a speed up in pipeline processing and the speed up is related to the number of stages.

15.2 Performance Issues

The cycle time τ of an instruction pipeline is the time needed to advance a set of instructions one stage through the pipeline. The cycle time can be determined as

$$\tau = \max[\tau_i] + d = \tau_m + d \quad 1 \leq i \leq k$$

where

τ_m = maximum stage delay (delay through stage which experience the largest delay)

k = number of stages in the instruction pipeline.

d = time delay of a latch, needed to advance signals and data from one stage to the next.

In general, the time delay d is equivalent to a clock pulse and $\tau_m \gg d$.

Now suppose that n instructions are processed and these instructions are executed one after another. The total time required T_k to execute all n instructions is

$$T_k = [k + (n - 1)] \tau$$

A total of k cycles are required to complete the execution of the first instruction, and the remaining $(n-1)$ instructions require $(n-1)$ cycles.

The time required to execute n instructions without pipeline is

$$T_1 = nk\tau$$

because to execute one instruction it will take $n\tau$ cycle.

The speed up factor for the instruction pipeline compared to execution without the pipeline is defined as:

$$S_k = \frac{T_1}{T_k} = \frac{nk\tau}{[k + (n-1)]\tau} = \frac{nk}{k + (n-1)} = \frac{nk}{(k-1) + n}$$

In general, the number of instruction executed is much more higher than the number of stages in the pipeline So, the n tends to α , we have

$$S_k = k,$$

i.e. We have a k fold speed up, the speed up factor is a function of the number of stages in the instruction pipeline.

Though, it has been seen that the speed up is proportional to number of stages in the pipeline, but in practice the speed up is less due to some practical reason. The factors that affect the pipeline performance is discussed next.

Effect of Intermediate storage buffer:

Consider a pipeline processor, which process each instruction in four steps;

F: Fetch, Read the instruction from the memory

D: Decode, decode the instruction and fetch the source operand (S)

O: Operate, perform the operation

W: Write, store the result in the destination location.

The hardware organization of this four-stage pipeline processor is shown in the Figure 9.5.

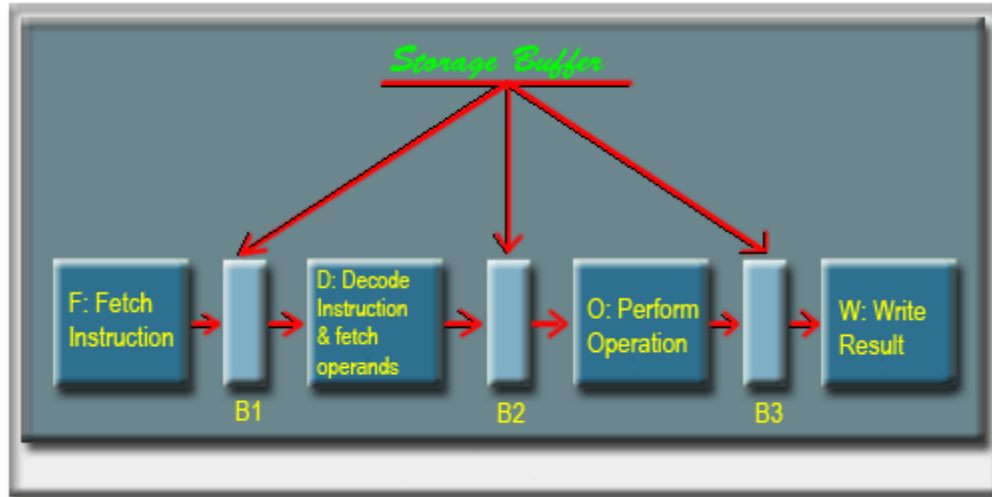

Figure 9.5: Four stage pipeline processor

In the preceding section we have seen that the speed up of pipeline processor is related to number of stages in the pipeline, i.e, the greater the number of stages in the pipeline, the faster the execution rate.

But the organization of the stages of a pipeline is a complex task and it affects the performance of the pipeline.

The problem related to a greater number of stages: At each stage of the pipeline, there is some overhead involved in moving data from buffer to buffer and in performing various preparation and delivery functions. This overhead can appreciably lengthen the total execution time of a single instruction. The amount of control logic required to handle memory and register dependencies and to optimize the use of the pipeline increases enormously with the number of stages.

Apart from hardware organization, there are some other reasons which may affect the performance of the pipeline.

(A) Unequal time requirement to complete a subtask:

Consider the four-stage pipeline with processing step Fetch, Decode, Operand and write. The stage-3 of the pipeline is responsible for arithmetic and logic operation, and in general one clock cycle is assigned for this task.

Although this may be sufficient for most operations, but some operations like divide may require more time to complete. Figure 9.6 shows the effect of an operation that takes more than one clock cycle to complete an operation in operate stage.

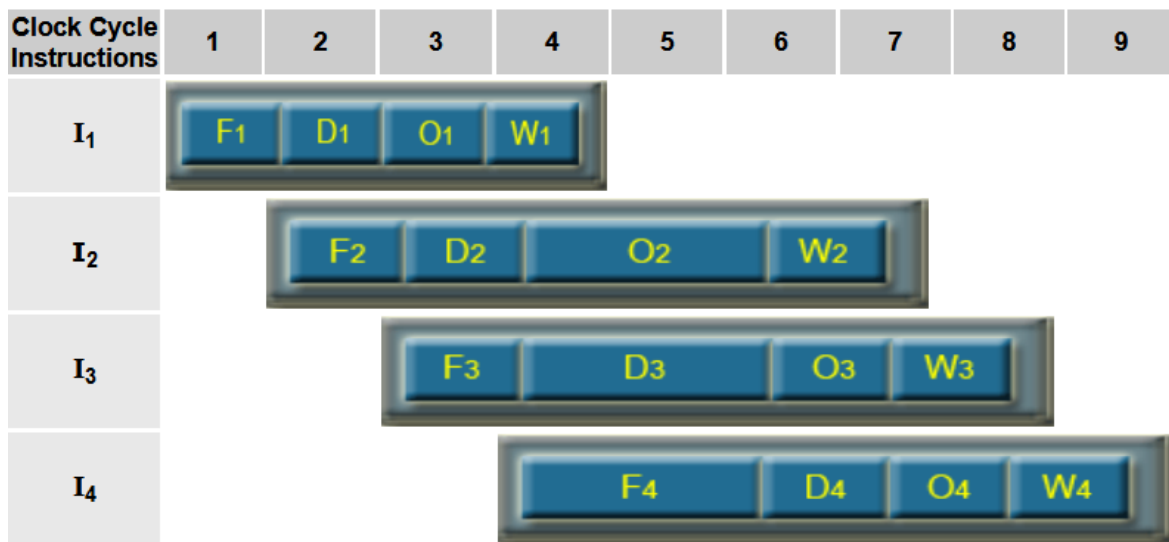

Figure 9.6: Operation takes more than one clock cycle

The operate stage for instruction I₂ takes 3 clock cycle to perform the specified operation. Clock cycle 4 to 6 required to perform this operation and so write stage is doing nothing during the clock cycle 5 and 6, because no data is available to write. Meanwhile, the information in buffer B₂ must remain intake until the operate stage has completed its operation.

This means that stage 2 and stage 1 are blocked from accepting new instructions because the information in B₁ cannot be overwritten by a new fetch instruction. The contents of B₁, B₂ and B₃ must always change at the same clock edge. Due to that reason, pipeline

operation is said to have been stalled for two clock cycle. Normal pipeline operation resumes in clock cycle 7. Whenever the pipeline stalled, some degradation in performance occurs.

Role of cache memory:

The use of cache memory solves the memory access problem Occasionally, a memory request results in a cache miss. This causes the pipeline stage that issued the memory request to take much longer time to complete its task and in this case the pipeline stalls. The effect of cache miss in pipeline processing is shown in the Figure 9.7.

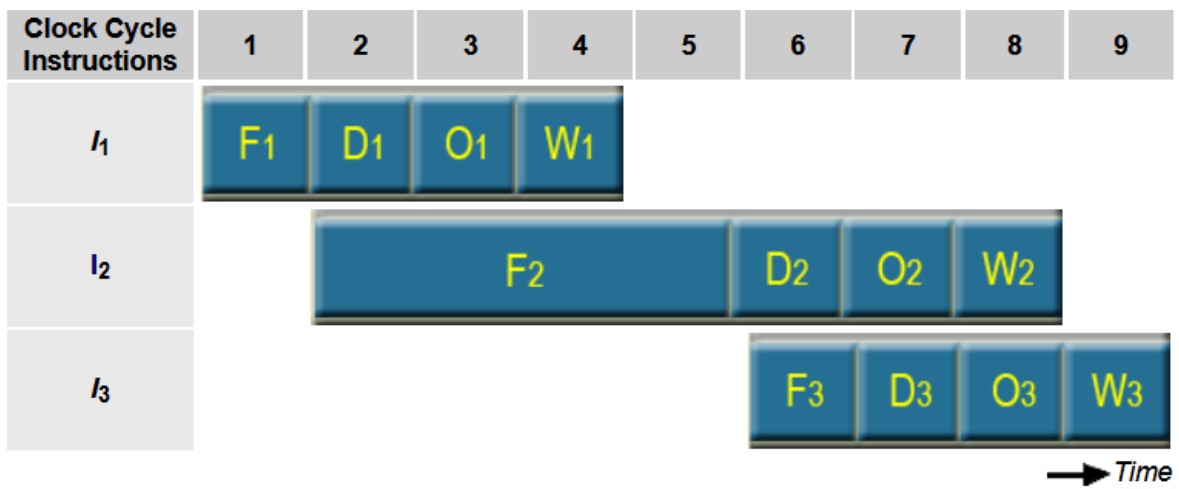

Figure 9.7: Effect of cache miss in pipeline processing



Figure 9.8: Function performed by each stage as a function of time

Function performed by each stage as a function of time is shown in Figure 9.8.

In this example, instruction I_1 is fetched from the cache in cycle 1 and its execution proceeds normally. The fetch operation for instruction I_2 which starts in cycle 2, results in a cache miss. The instruction fetch unit must now suspend any further fetch requests and wait I_2 for to arrive.

We assume that instruction I_2 is received and loaded into buffer B1 at the end of cycle 5, It appears that cache memory used here is four time faster than the main memory. The pipeline resumes its normal operation at that point and it will remain in normal operation mode for some times, because a cache miss generally transfer a block from main memory to cache. From the figure, it is clear that Decode unit, Operate unit and Write unit remain idle for three clock cycle. Such idle periods are sometimes referred to as bubbles in the pipeline.

Once created as a result of a delay in one of the pipeline stages, a bubble moves downstream until it reaches the last unit. A pipeline cannot stall as long as the instructions and data being accessed reside in the cache. This is facilitated by providing separate on chip instruction and data caches.

Dependency Constraints:

Consider the following program that contains two instructions, followed by

$I_1: A \leftarrow A + 5$

$I_2: B \leftarrow 3 * A$

When this program is executed in a pipeline, the execution of can begin before the execution of completes. The pipeline execution is shown in Figure 9.9.

Clock Cycle Stages	1	2	3	4	5	6
F: Fetch	F ₁	D ₁	O ₁	W ₁		
D: Decode		F ₂	D ₂	O ₂	W ₂	

Figure 9.9: Pipeline execution of two instructions

In clock cycle 3, the specific operation of instruction I₁ i.e. addition takes place and at that time only the new updated value of A is available. But in the clock cycle 3, the instruction I₂ is fetching the operand that is required for the operation of I₂. Since in clock cycle 3 only, operation of instruction I₁ is taking place, so the instruction I₂ will get the old value of A, it will not get the updated value of A, and will produce a wrong result. Consider that the initial value of A is 4. The proper execution will produce the result as

$$B=27$$

$$I_1: A \leftarrow A + 5 = 4 + 5 = 9$$

$$I_2: B \leftarrow 3 \times A = 3 \times 9 = 27$$

But due to the pipeline action, we will get the result as

$$I_1: A \leftarrow A + 5 = 4 + 5 = 9$$

$$I_2: B \leftarrow 3 \times A = 3 \times 4 = 12$$

Due to the data dependency, these two instructions cannot be performed in parallel.

Therefore, no two operations that depend on each other can be performed in parallel. For correct execution, it is required to satisfy the following:

- The operation of the fetch stage must not depend on the operation performed during the same clock cycle by the execution stage.
- The operation of fetching an instruction must be independent of the execution results of the previous instruction.
- The dependency of data arises when the destination of one instruction is used as a source in a subsequent instruction.



Check your progress I

1. The pipelining process is also called as _____
 - a) Superscalar operation
 - b) Assembly line operation
 - c) Von Neumann cycle
 - d) None of the mentioned
2. The fetch and execution cycles are interleaved with the help of _____
 - a) Modification in processor architecture
 - b) Clock
 - c) Special unit
 - d) Control unit
3. Each stage in pipelining should be completed within _____ cycle.
 - a) 1
 - b) 2
 - c) 3
 - d) 4
4. If a unit completes its task before the allotted time period, then _____
 - a) It'll perform some other task in the remaining time
 - b) Its time gets reallocated to a different task
 - c) It'll remain idle for the remaining time
 - d) None of the mentioned

15.3 Branching

In general, when we are executing a program the next instruction to be executed is brought from the next memory location. Therefore, in pipeline organization, we are fetching instructions one after another.

But in case of conditional branch instruction, the address of the next instruction to be fetched depends on the result of the execution of the instruction.

Since the execution of next instruction depends on the previous branch instruction, sometimes it may be required to invalidate several instruction fetches. Consider the following instruction execution sequence of Figure 9.10.

Time	1	2	3	4	5	6	7	8	9	10
Instruction										
I_1	F_1	D_1	O_1	W_1						
I_2		F_2	D_2	O_2	W_2					
I_3			F_3	D_3	O_3	W_3				
I_4				F_4	D_4	O_4	W_4			
I_5					F_5	D_5	O_5	W_5		
I_6						F_6	D_6	O_6	W_6	
I_7							F_7	D_7	O_7	W_7

Figure 9.10: An instruction execution sequence

In this instruction sequence, consider that I_3 is a conditional branch instruction.

The result of the instruction will be available at clock cycle 5. But by that time the fetch unit has already fetched the instruction I_4 and I_5 .

If the branch condition is false, then branch won't take place and the next instruction to be executed is which is already fetched and available for execution.

Now consider that when the condition is true, we have to execute the instruction I_{10} . After clock cycle 5, it is known that branch condition is true and now instruction I_{10} has to be executed.

But already the processor has fetched instruction I_4 and I_5 . It is required to invalidate these two fetched instructions and the pipeline must be loaded with new destination instruction I_{10} .

Due to this reason, the pipeline will stall for some time. The time lost due to branch instruction is often referred to as branch penalty.

Time Instruction	1	2	3	4	5	6	7	8	9	10
I_1	F_1	D_1	O_1	W_1						
I_2		F_2	D_2	O_2	W_2					
I_3			F_3	D_3	O_3	W_3				
I_4				F_4	D_4					
I_5					F_5					
I_{10}						F_{10}	D_{10}	O_{10}	W_{10}	
I_{11}							F_{11}	D_{11}	O_{11}	W_{11}

Figure 9.11: The effect of branch takes place

The effect of branch takes place is shown in the Figure 9.11. Due to the effect of branch takes place, the instruction I_4 and I_5 which has already been fetched is not executed and new instruction I_{10} is fetched at clock cycle 6. There is not effective output in clock cycle 7 and 8, and so the branch penalty is 2. The branch penalty depends on the number of stages in the pipeline. More numbers of stages results in more branch penalty.

Dealing with Branches:

One of the major problems in designing an instruction pipe line is assuming a steady flow of instructions to the initial stages of the pipeline. The primary problem is the conditional branch instruction until the instruction is actually executed, it is impossible to determine whether the branch will be taken or not. A variety of approaches have been taken for dealing with conditional branches:

- Multiple streams
- Prefetch branch target
- Loop buffer
- Branch prediction
- Delayed branch

Multiple streams

A single pipeline suffers a penalty for a branch instruction because it must choose one of two instructions to fetch next and sometimes it may make the wrong choice. A brute-force approach is to replicate the initial portions of the pipeline and allow the pipeline to fetch both instructions, making use of two streams. There are two problems with this approach. With multiple pipelines there are contention delays for access to the registers and to memory. Additional branch instructions may enter the pipeline (either stream) before the original branch decision is resolved. Each such instruction needs an additional stream.

Prefetch Branch target

When a conditional branch is recognized, the target of the branch is prefetched, in addition to the instruction following the branch. This target is then saved until the branch instruction is executed. If the branch is taken, the target has already been prefetched.

Loop Buffer

A top buffer is a small, very high-speed memory maintained by the instruction fetch stage of the pipeline and containing the most recently fetched instructions, in sequence.

If a branch is to be taken, the hardware first checks whether the branch target is within the buffer. If so, the next instruction is fetched from the buffer.

The loop buffer has three benefits:

1. With the use of prefetching, the loop buffer will contain some instruction sequentially ahead of the current instruction fetch address. Thus, instructions fetched in sequence will be available without the usual memory access time.
2. If a branch occurs to a target just a few locations ahead of the address of the branch instruction, the target will already be in the buffer. This is usual for the common occurrence of IF-THEN and IF-THEN-ELSE sequences.
3. This strategy is particularly well suited for dealing with loops, or iterations; hence the name loop buffer. If the loop buffer is large enough to contain all the instructions in a loop, then those instructions need to be fetched from memory only once, for the first iteration. For subsequent iterations, all the needed instructions are already in the buffer.

The loop buffer is similar in principle to a cache dedicated to instructions. The differences are that the loop buffer only retains instructions in sequence and is much smaller in size and hence lower in cost.

Branch Prediction

Various techniques can be used to predict whether a branch will be taken or not. The most common techniques are:

- Predict never taken
- Predict always taken
- Predict by opcode
- Taken/not taken switch
- Branch history table.

The first three approaches are static; they do not depend on the execution history upto the time of the conditional branch instructions. The later two approaches are dynamic- they depend on the execution history.

Predict never taken always assumes that the branch will not be taken and continue to fetch instruction in sequence.

Predict always taken assumes that the branch will be taken and always fetch the branet target In these two approaches it is also possible to minimize the effect of a wrong decision.

If the fetch of an instruction after the branch will cause a page fault or protection violation, the processor halts its prefetching until it is sure that the instruction should be fetched.

Studies analyzing program behavior have shown that conditional branches are taken more than 50% of the time [LILJ88}, and so if the cost of prefetching from either path is the same, then always prefetching from the branch target address should give better performance than always prefetching from the sequential path.

However, in a paged machine, prefetching the branch target is more likely to cause a page fault than prefetching the next instruction in the sequence and so this performance penalty should be taken into account.

Predict by opcode approach makes the decision based on the opcode of the branch instruction. The processor assumes that the branch will be taken for certain branch opcodes and not for others. Studies reported in [LILJ88}showed that success rate is greater than 75% with the strategy.

[LILJ88} Lilja,D "Reducing the branch penalty in pipeline processors", computer, July 1988.

Dynamic branch strategies attempt to improve the accuracy of prediction by recording the history of conditional branch instructions in a program. Scheme to maintain the history information:

- One or more bits can be associated with each conditional branch instruction that reflect the recent history of the instruction.
- These bits are referred to as a taken/not taken switch that directs the processor to make a particular decision the next time the instruction is encountered.
- Generally, these history bits are not associated with the instruction in main memory. It will unnecessarily increase the size of the instruction. With a single bit we can record whether the last execution of this instruction resulted a branch or not.
- With only one bit of history, an error in prediction will occur twice for each use of the loop: once for entering the loop. And once for exiting.

If two bits are used, they can be used to record the result of the last two instances of the execution of the associated instruction. The history information is not kept in main memory, it can be kept in a temporary high-speed memory. One possibility is to associate these bits with any conditional branch instruction that is in a cache. When the instruction is replaced in the cache, its history is lost.

Another possibility is to maintain a small table for recently executed branch instructions with one or more bits in each entry.

The branch history table is a small cache memory associated with the instruction fetch stage of the pipeline. Each entry in the table consists of three elements:

- The address of the branch instruction.
- Some member of history bits that record the state of use of that instruction.
- Information about the target instruction, it may be the address of the target instruction, or may be the target instruction itself.

Delayed Branch

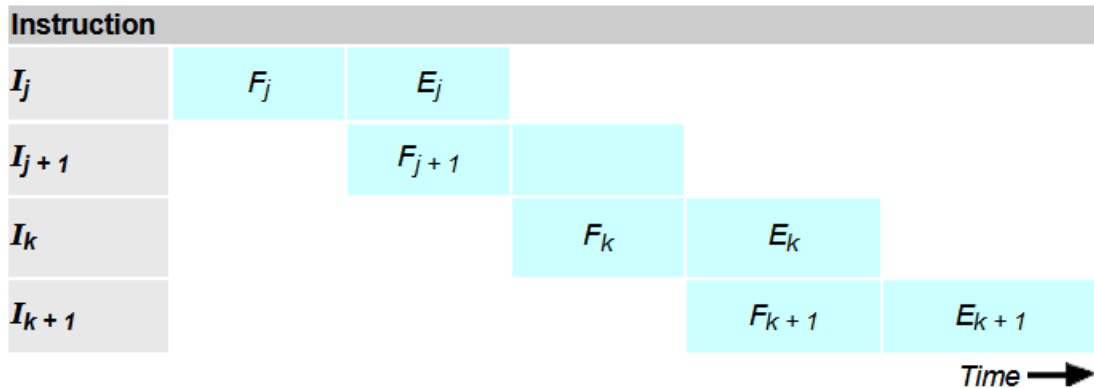

Figure 9.12: Instructions in pipeline with branch instruction.

The Figure 9.12 shows the execution of instructions in pipeline where the instruction I_j is a branch instruction.

The instruction I_j is a branch instruction. The processor begins fetching instruction I_{j+1} before it determines whether the current instruction I_j is a branch instruction.

When execution of I_j is completed and a branch must be made, the processor must discard the instruction that was fetched and now fetch the instruction at the branch target.

The location following a branch instruction is called a branch delay slot. There may be more than one branch delay slot, depending on the time it takes to execute a branch instruction.

The instructions in the delay slots are always fetched and at least partially executed before the branch decision is made and the branch target address is computed.

Delayed branching is a technique to minimize the penalty incurred as a result of conditional branch instructions.

The instructions in the delay slots are always fetched, so we can arrange the instruction in delay slots to be fully executed whether or not the branch is taken. The objective is to plane

useful instruction in these slots. If no useful instructions can be placed in the delay slots, these slots must be filled with NOP (no operation) instructions. For example, consider the consider the following code segments given in the Figure 9.13.

<i>I₁</i>	<i>LOOP</i>	<i>Shift_left</i>	<i>R1</i>
<i>I₂</i>		<i>Decrement</i>	<i>R2</i>
<i>I₃</i>		<i>Branch_if $\neq 0$</i>	<i>LOOP</i>
<i>I₄</i>	<i>NEXT</i>	<i>Add</i>	<i>R1,R3</i>

Figure 9.13: Original Program Loop

Here register *R₂* is used as a counter to determine the number of times the contents of register *R₁* are sifted left. Consider a processor with a two-stage pipeline and one delay slot. During the execution phase of the instruction *I₃*, the fetch unit will fetch the instruction *I₄*. After evaluating the branch condition only, it will be clear whether instruction *I₁* or *I₄* will be executed next. The nature of the code segment says that it will remain in the top depending on the initial value of *R₂* and when it becomes zero, it will come out from the loop and execute the instruction *I₄*. During the loop execution, every time there is a wrong fetch of instruction *I₄*. The code segment can be recognized without disturbing the original meaning of the program. The reordered code segment is shown in Figure 9.14.

<i>LOOP</i>	<i>Decrement</i>	<i>R2</i>
	<i>Branch_if $\neq 0$</i>	<i>LOOP</i>
	<i>Shift_left</i>	<i>R1</i>
<i>NEXT</i>	<i>Add</i>	<i>R1,R3</i>

Figure 9.14: Reordered instructions for program loop

In this case, the shift instruction is fetched while the branch instruction is being executed. After evaluating the branch condition, the processor fetches the instruction at LOOP or at NEXT, depending on whether the branch condition is true or false, respectively. In either case, it completes execution of the shift instruction.

Logically the program is executed as if the branch instruction was placed after the shift instruction. That is, branching takes place one instruction later than where the branch instruction appears in the instruction sequence in the memory, hence the name “delayed branch” .

Figure 9.15 shows the execution timing for the last two passes through the loop of reordered instructions.

Figure 9.16 shows the execution timing for the last two passes through the loop of the original program loop.

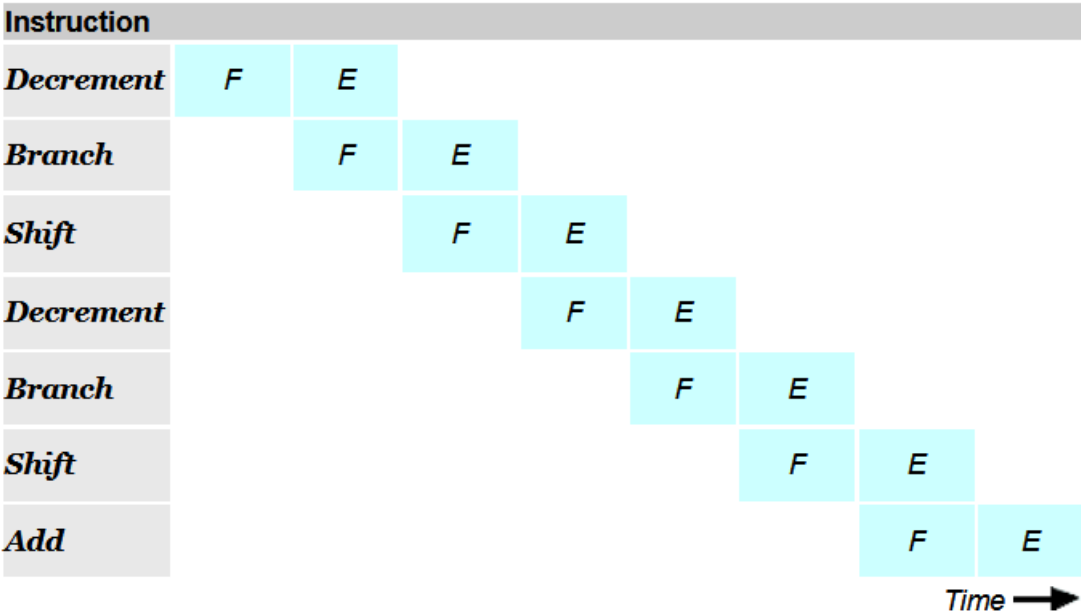

Figure 9.15: Execution timing for last two passes through the loop of reordered instruction

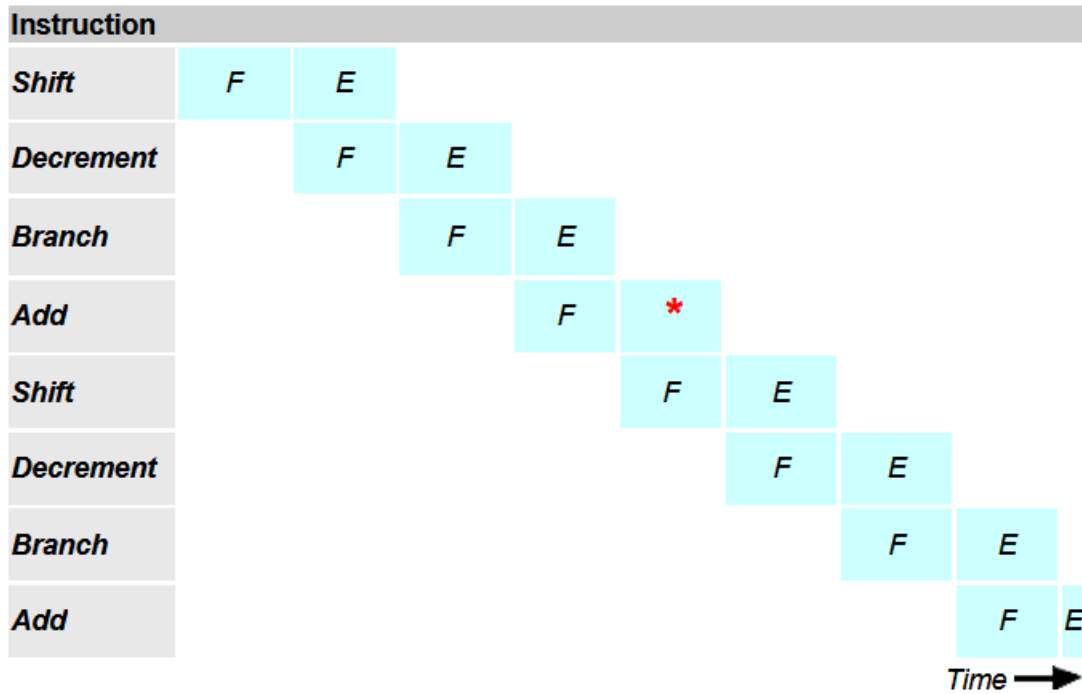

Figure 9.16: Execution timing for last two passes through the loop of the original program loop

*Note : Execution Unit Idle



Check your progress II

- To increase the speed of memory access in pipelining, we make use of _____
 - Special memory locations
 - Special purpose registers
 - Cache
 - Buffers
- The situation wherein the data of operands are not available is called _____
 - Data hazard
 - Stock
 - Deadlock
 - Structural hazard

3. The _____ depends on the number of stages in the pipeline.
4. A _____ is a small, very high-speed memory maintained by the instruction fetch stage of the pipeline and containing the most recently fetched instructions, in sequence.

15.4 Summary

1. Pipelining is the process of accumulating instruction from the processor through a pipeline. It allows storing and executing instructions in an orderly process. It is also known as pipeline processing.
2. Pipelining increases the overall instruction throughput.
3. Pipelining is a technique where multiple instructions are overlapped during execution.
4. There are some factors that cause the pipeline to deviate its normal performance like timing variations, data hazards, Branching, interrupts and data dependency.

15.5 Model Questions

1. Explain the concept of instruction pipeline.
2. How do you evaluate the performance enhancement of a pipeline processor with d number of phases with respect to a processor without pipeline?
3. Why is a two-stage instruction pipeline unlikely to cut the instruction cycle time in half, compared with the use of no pipeline?
4. What is branch penalty?
5. What do you mean by static branch strategies and dynamic branch strategies to deal with branches in pipeline processor?
6. What is a branch history table and how it is used to deal with branches?
7. Explain the concept of delayed branching technique.
8. What is a loop buffer? How loop buffer is used to handle the branching in pipeline processor?



Answers to Check your progress I

1. b
2. b
3. a
4. c



Answers to Check your progress II

1. c
2. a
3. branch penalty
4. top buffer

PARALLEL PROCESSING

16.0 Learning Objectives

After completing this unit, the learner shall be able to:

- Explain the organization of a multiprocessor system;
- Define a symmetric multiprocessor (SMP);
- Classify the organization of multiprocessor system;
- Explain multiport memory organization;
- Explain NUMA architecture;
- Explain Crossbar Network;
- Define cache coherence;

16.1 Parallel Processing

Originally, the computer has been viewed as a sequential machine. Most computer programming languages require the programmer to specify algorithms as sequence of instruction.

Processor executes programs by executing machine instructions in a sequence and one at a time. Each instruction is executed in a sequence of operations (fetch instruction, fetch operands, perform operation store result.)

It is observed that, at the micro operation level, multiple control signals are generated at the same time.

Instruction pipelining, at least to the extent of overlapping fetch and execute operations, has been around for long time.

By looking into these phenomena, researcher has look into the matter whether some operations can be performed in parallel or not.

As computer technology has evolved, and as the cost of computer hardware has dropped, computer designers have sought more and more opportunities for parallelism, usual to enhance performance and, in some cases, to increase availability.

- Single Instruction, Multiple Data (SIMD) system: A single machine instruction controls the simultaneous execution of a number of processing elements on a lockstep basis. Each processing element has an associated data memory, so that each instruction is executed on a different set of data by the different processors. Vector and array processors fall into this category.
- Multiple Instruction, Single Data (MISD) system A sequence of data is transmitted to a set of processors, each of which executes a different instruction sequence. This structure has never been implemented.
- Multiple Instruction, Multiple Data (MIMD) system: A set of processors simultaneously execute different instruction sequences on different data sets. SMPs, clusters, and NUMA systems fits into this category.
- With the MIMD organization, the processors are general purpose; each is able to process all of the instructions necessary to perform the appropriate data transformation.
- Further MIMD can be subdivided into two main categories:
- Symmetric multiprocessor (SMP): In an SMP, multiple processors share a single memory or a pool of memory by means of a shared bus or other interconnection mechanism. A distinguish feature is that the memory access time to any region of memory is approximately the same for each processor.
- Nonuniform memory access (NUMA): The memory access time to different regions of memory may differ for a NUMA processor.

The design issues relating to SMPs and NUMA are complex, involving issues relating to physical organization, interconnection structures, inter processor communication, operating system design, and application software techniques.

Symmetric Multiprocessors

A symmetric multiprocessor (SMP) can be defined as a standalone computer system with the following characteristic:

1. There are two or more similar processor of comparable capability.
2. These processors share the same main memory and I/O facilities and are interconnected by a bus or other internal connection scheme.
3. All processors share access to I/O devices, either through the same channels or through different channels that provide paths to the same device.
4. All processors can perform the same functions.
5. The system is controlled by an integrated operating system that provides interaction between processors and their programs at the job, task, file and data element levels.
6. The operating system of a SMP schedules processors or thread across all of the processors. SMP has a potential advantage over uniprocessor architecture:
 - a. Performance: A system with multiple processors will perform in a better way than one with a single processor of the same type if the task can be organized in such a manner that some portion of the work done can be done in parallel.
 - b. Availability: Since all the processors can perform the same function in a symmetric multiprocessor, the failure of a single processor does not stop the machine. Instead, the system can continue to function at reduce performance level.
 - c. Incremental growth: A user can enhance the performance of a system by adding an additional processor.
 - d. Sealing: Vendors can offer a range of product with different price and performance characteristics based on number of processors configured in the system.

Organization

The organization of a multiprocessor system is shown in Figure 10.1

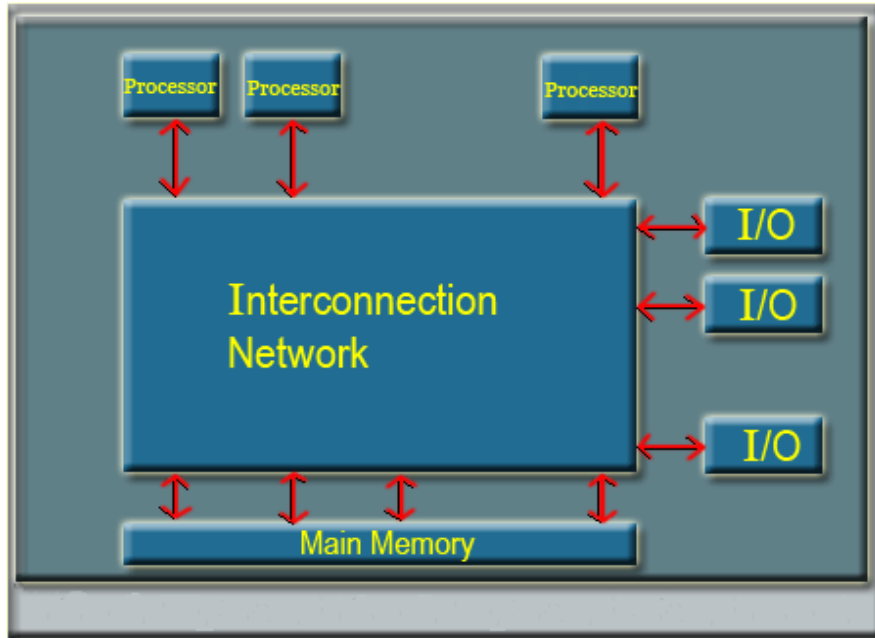

Figure 10.1: Block diagram of tightly coupled multiprocessors

- There are two or more processors. Each processor is self-sufficient, including a control unit, ALU, registers and cache.
- Each processor has access to a shared main memory and the I/O devices through an interconnection network.
- The processor can communicate with each other through memory (messages and status information left in common data areas).
- It may also be possible for processors to exchange signal directly.
- The memory is often organized so that multiple simultaneous accesses to separate blocks of memory are possible.
- In some configurations each processor may also have its own private main memory and I/O channels in addition to the shared resources.

The organization of multiprocessor system can be classified as follows:

- Time shared or common bus
- Multiport memory
- Central control unit.

Time shared Bus

Time shared bus is the simplest mechanism for constructing a multiprocessor system. The bus consists of control, address and data lines. The block diagram is shown in Figure 10.2.

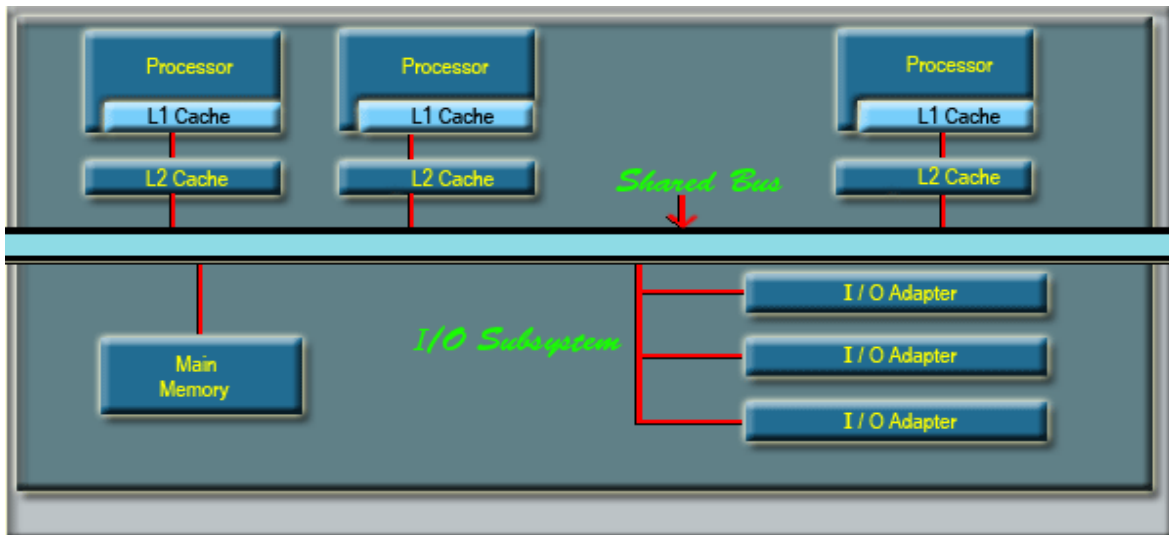

Figure 10.2: Time shared bus

The following features are provided in time-shared bus organization:

- Addressing: It must be possible to distinguish modules on the bus to determine the source and destination of data
- Arbitration: Any I/O module can temporarily function as “master”. A mechanism is provided to arbitrate competing request for bus control, using some sort of priority scheme.
- Time shearing: when one module is controlling the bus, other modules are locked out and if necessary, suspend operation until bus access in achieved.

The bus organization has several advantages compared with other approaches:

- Simplicity: This is the simplest approach to multiprocessor organization. The physical interface and the addressing, arbitration and time-sharing logic of each processor remain the same as in a single processor system.
- Flexibility: It is generally easy to expand the system by attaching more processor to the bus.

- Reliability: The bus is essentially a passive medium and the failure of any attached device should not cause failure of the whole system.

The main drawback to the bus organization is performance. Thus, the speed of the system is limited by the bus cycle time. To improve performance, each processor can be equipped with local cache memory. The use of cache leads to a new problem which is known as cache coherence problem. Each local cache contains an image of a portion of main memory. If a word is altered in one cache, it may invalidate a word in another cache. To prevent this, the other processors must perform an update in its local cache.

Multiport Memory

The multiport memory approach allows the direct, independent access of main memory modules by each processor and I/O module. The multiport memory system is shown in Figure 10.3

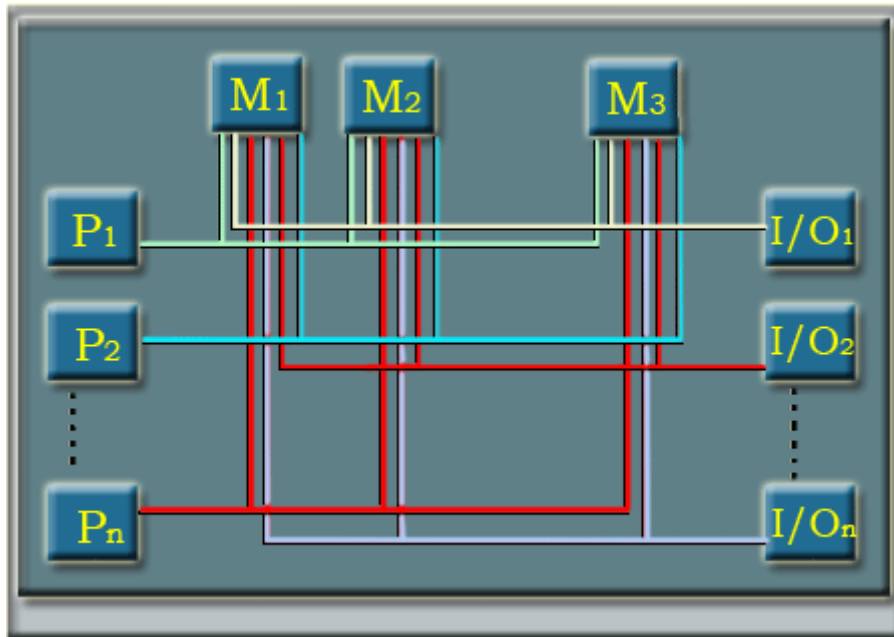

Figure 10.3: Multiport memory

The multiport memory approach is more complex than the bus approach, requiring a fair amount of logic to be added to the memory system. Logic associated with memory is required for resolving conflict. The method often used to resolve conflicts is to assign permanently designated priorities to each memory port.

Non-uniform Memory Access (NUMA)

In NUMA architecture, all processors have access to all parts of main memory using loads and stores. The memory access time of a processor differs depending on which region of main memory is accessed. The last statement is true for all processors; however, for different processors, which memory regions are slower and which are faster differ.

A NUMA system in which cache coherence is maintained among the cache of the various processors is known as cache-coherence NUMA (CC-NUMA). A typical CC-NUMA organization is shown in the Figure 10.4.

There are multiple independent nodes, each of which is, in effect, an SMP organization. Each node contains multiple processors, each with its own L1 and L2 caches, plus main memory. The node is the basic building block of the overall CC NUMA organization. The nodes are interconnected by means of some communication facility, which could be a switching mechanism, a ring, or some other networking facility.

Each node in the CC-NUMA system includes some main memory. From the point of view of the processors, there is only a single addressable memory, with each location having a unique system-wide address. When a processor initiates a memory access, if the requested memory location is not in the processors cache, then the L2 cache initiates a fetch operation. If the desired line is in the local portion of the main memory, the line is fetched across the local bus.

If the desired line is in a remote portion of the main memory, then an automatic request is sent out to fetch that line across the interconnection network, deliver it to the local bus, and then deliver it to the requesting cache on that bus.

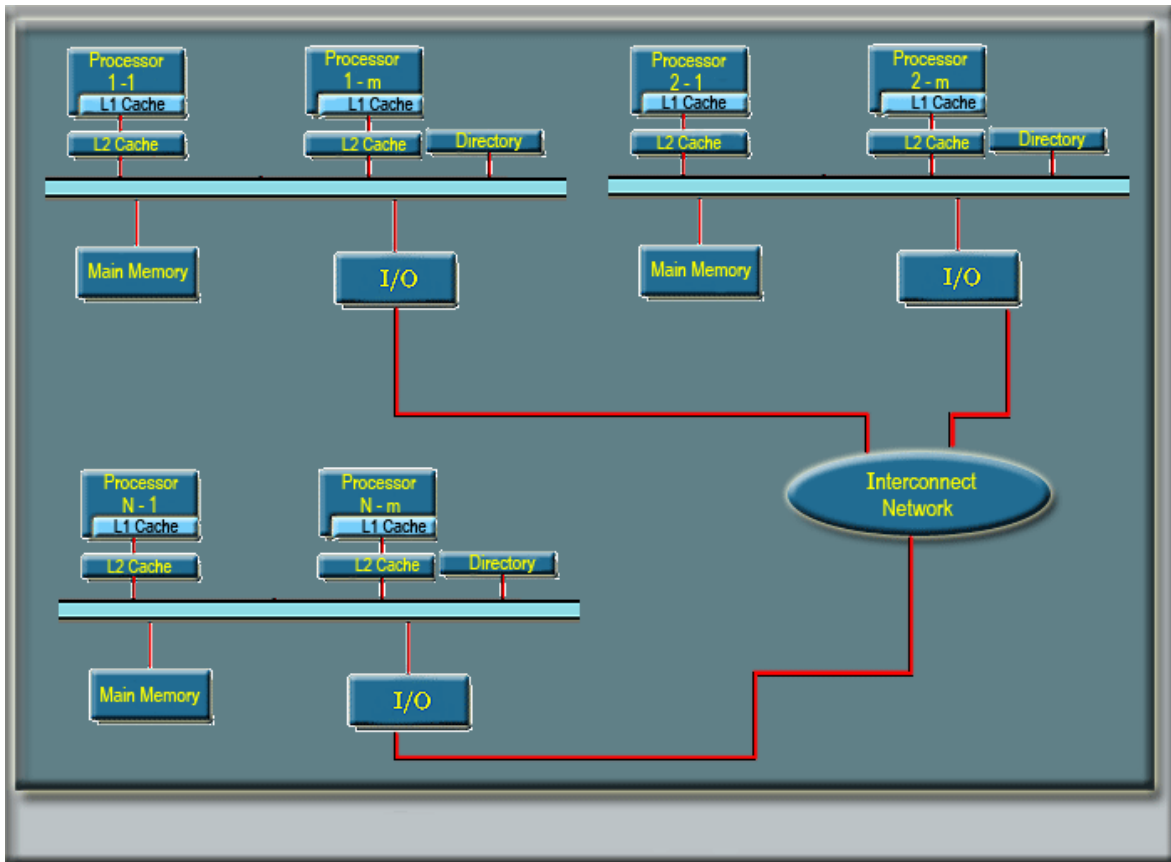

Figure 10.4: CC- NUMA Organization

All of this activity is atomic and transparent to the processors and its cache. In this configuration, cache coherence is a central concern. For that each node must maintain some sort of directory that gives it an indication of the location of various portion of memory and also cache status information.

16.2 Interconnection Networks

In a multiprocessor system, the interconnection network must allow information transfer between any pair of modules in the system. The traffic in the network consists of requests (such as read and write), data transfers, and various commands.

Single Bus

The simplest and most economical means of interconnecting a number of modules is to use a single bus. Since several modules are connected to the bus and any module can request a data transfer at any time, it is essential to have an efficient bus arbitration scheme. In a simple mode of operation, the bus is dedicated to a particular source-destination pair for the full duration of the requested transfer. For example, when a processor uses a read request on the bus, it holds the bus until it receives the desired data from the memory module. Since the memory module needs a certain amount of time to access the data bus, the bus will be idle until the memory is ready to respond with the data. Then the data is transferred to the processors. When this transfer is completed, the bus can be assigned to handle another request.

A scheme known as the split- transaction protocol makes it possible to use the bus during the idle period to serve another request.

Consider the following method of handling a series of read requests possibly from different processor. After transferring the address involved in the first request, the bus may be reassigned to transfer the address of the second request; assuming that this request is to a different memory module. At this point, we have two modules proceeding with read access cycle in parallel. If neither module has finished with its access, the bus may be reassigned to a third request and so on. Eventually, the first memory module completes its access cycle and uses the bus to transfer the data to the corresponding source.

As other modules complete their cycles, the bus is needed to transfer their data to the corresponding sources. The split transaction protocol allows the bus and the available bandwidth to be used more efficiently. The performance improvement achieved with this protocol depends on the relationship between the bus transfer time and the memory access time.

In split- transaction protocol, performance is improved at the cost of increased bus complexity. There are two reasons why complexity increases:

- Since a memory module needs to know which source-initiated a given read request, a source identification tag must be attached to the request.
- Complexity also increases because all modules, not just the processor, must be able to act as bus master.

The main limitation of a single bus is that the number of modules that can be connected to the bus is not that large. Networks that allow multiple independent transfer operations to proceed in parallel can provide significantly increased data transfer rate.

Crossbar Network

Crossbar switch is a versatile switching network. It is basically a network of switches. Any module can be connected to any other module P_i by closing the appropriate switch. Such networks, where there is a direct link between all pairs of nodes are called fully connected networks.

In a fully connected network, many simultaneous transfers are possible. If n sources need to send data to n distinct destinations then all of these transfers can take place concurrently. Since no transfer is prevented by the lack of a communication path, the crossbar is called a nonblocking switch. In the Figure 10.5 of crossbar interconnection network, a single switch is shown at each cross point. In actual multiprocessor system, the paths through the crossbar network are much wider.

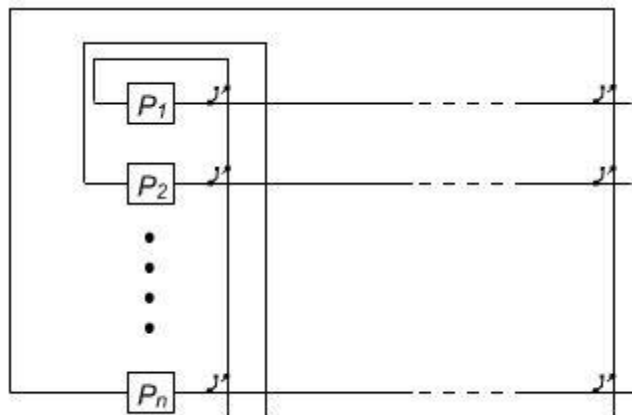

Figure 10.5: Crossbar Interconnection Network

If there are modules in a network, then the number of cross point is n^2 in a network to interconnect modules. The total number of switches becomes large as n increases.

Multistage Network

The bus and crossbar systems use a single stage of switching to provide a path from a source to a destination. In multistage network, multiple stages of switches are used to setup a path between source and destination. Such networks are less costly than the crossbar structure, yet they provide a reasonably large number of parallel paths between source and destinations.

In the Figure 10.6, it shows a three-stage network that called a shuffle network that interconnects eight modules. The term "shuffle" describes the pattern of connections from the outputs of one stage to the inputs of the next stage. The switchbox in the Figure 10.6 is a switch that can route either input to either output. If the inputs request distinct outputs, they can both be routed simultaneously in the straight through or crossed pattern. If both inputs request the same output, only one request can be satisfied. The other one is blocked until the first request finishes using the switch.

In a crossbar switch, conflicts occur when two or more concurrent requests are made to the same destination device. These conflicting requests are usually handled on a predetermined priority basis.

The crossbar switch has the potential for the highest bandwidth and system efficiency. However, because of its complexity and cost, it may be cost effective for a large multiprocessor system.

A network consisting of s stages can be used to interconnect 2^s modules. In this case, there is exactly one path through the network from any module P_i to any module P_j . Therefore, this network provides full connectivity between sources and destinations. Many request patterns cannot be satisfied simultaneously. For example, the connection from P_2 to P_7 can not be provided at the same time as the connection from P_3 to P_6 .

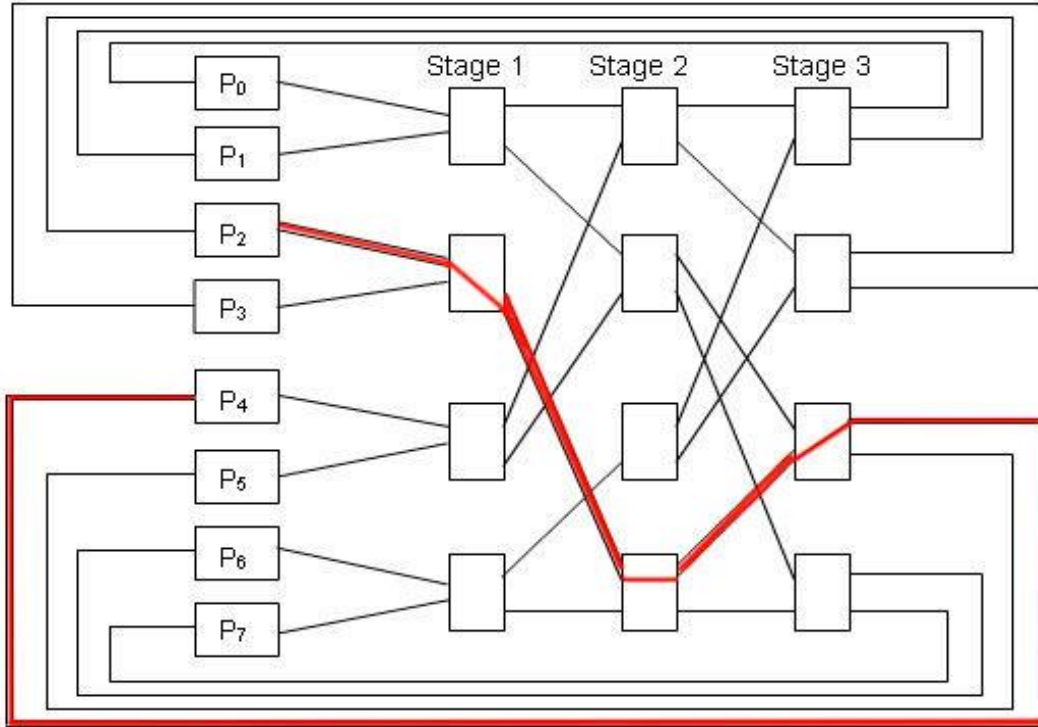

Figure 10.6: Multistage Shuffle Network

A multistage network is less expensive to implement than a crossbar network. If nodes are to be interconnected using this scheme, then we must use $s = \log_2 n$ stages with $n/2$ switches per stage. Since each switches contains four switches, the total number of switches is:

$$4 * \frac{n}{2} * \log_2 n = 2n * \log_2 n$$

which, for a large network, is considerably less than the switches needed in a crossbar network. Multistage networks are less capable of providing concurrent connection than crossbar n^2 switches. The connection path between P₂ and P₄ is indicated by RED lines in the Figure 10.6.

Hypercube Networks

A hypercube is an n -dimensional cube that interconnects nodes. In addition to the communication circuit, each node usually includes a processor and a memory module as well as some I/O capability.

The Figure 10.7 shows a three dimensional hypercube. The small circles represent the communication circuits in the nodes. The edge of the cube represent bi-directional communication links between neighboring nodes.

In an n -dimensional hypercube each node is directly connected to neighbors. A useful way to label the nodes is to assign binary addresses to them in such a way that the addresses of any two neighbors differs in exactly one bit position. The functional units are attached to each node of the hypercube.

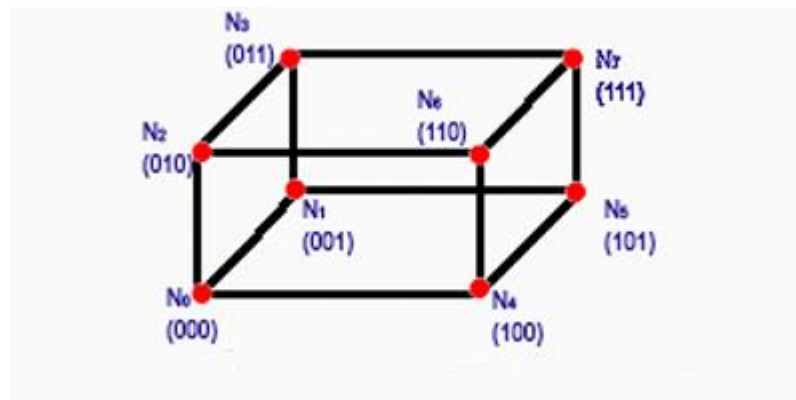

Figure 10.7: A 3-dimensional Hypercube Network

Routing messages through the hypercube is easy. If the processor at node N_i wishes to send a message to node N_j , it proceeds as follows:

- The binary addresses of the source, i , and the destination, j , are compared from least to most significant bits.
- Suppose that they differ first in position P .

- Node N_i then sends the message to its neighbor whose address, k , differs from i in bit position P .
- Node N_k forwards the message to the appropriate neighbor using the same address comparison scheme
- The message gets closer to destination node N_j with each of these hops from one node to another.

For example, a message from node to transverse the following way:

$$N_0: 000 \quad N_5: 101$$

Message traverses from node N_0 to N_1 , they differ in 1st bit position.

Then message traverses from N_1 to N_5 , they differ in 3rd bit position.

Therefore, it takes two hops. The maximum distance that any message needs to travel in an- dimensional hypercube is n - hops.

Mesh networks

Mesh network is another way to interconnect a large number of nodes in a multiprocessor system. An example of a mesh with 16 nodes is given in the Figure 10.8.

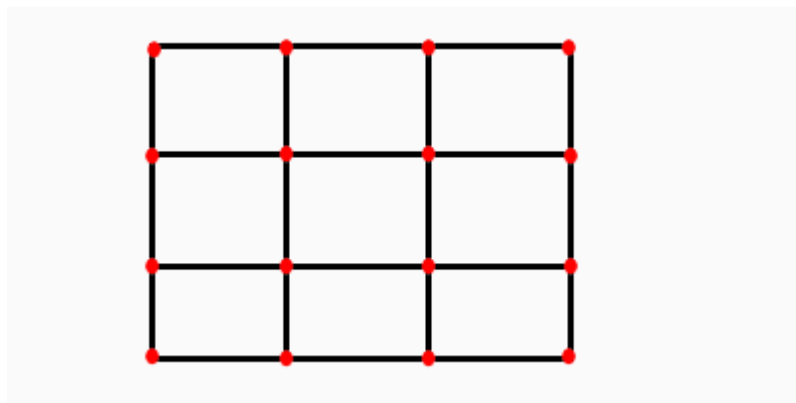

Figure 10.8: A 2-D Mesh Network

The link between the nodes are bi-directional.

The functional unit are attached to each node of the mesh network.

Routing in a mesh network can be done in several ways.

One of the simplest and most effective possibilities is to choose the path between a source node N_i and a destination node N_j such that the transfer first takes place in the horizontal directional from N_i towards N_j .

When the column in which N_j resides is reached, the transfer proceeds in the vertical direction along this column. If a wraparound connection is made between the nodes at the opposite edges of a mesh network, the result is a network that comprises a set of bi-directional rings in the X direction connected by a set of rings in the Y direction.

This network is called a torus. The average latency of information transfer is reduced in a torus, but the complexity increases.

Tree Networks

A hierarchically structured network implemented in the form of a tree is another interconnection topology. A four way tree that interconnects 16 modules is shown in the Figure 10.9.

In this tree, each parent node allows communication between two of its children at a time.

An intermediate-level node, for example node in the figure, can provide a connection from one of its child node to its parent. This enables two leaf nodes that are any distance apart to communicate. Only one path at any time can be established through a given node in the tree.

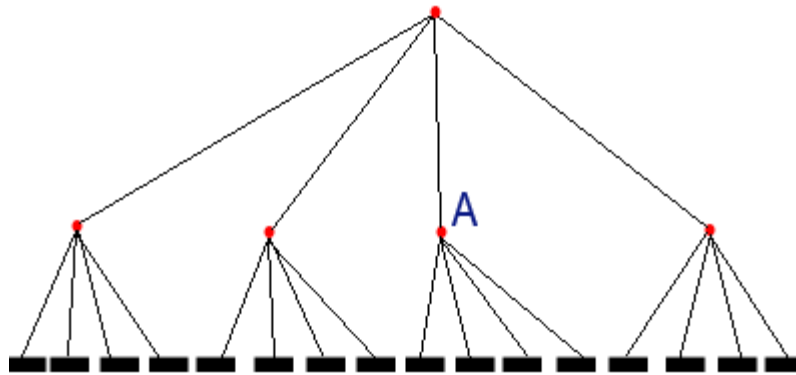

Figure 10.9: A four way Tree Network

To reduce the possibility of a bottleneck, the number of links in the upper levels of a tree hierarchy can be increased. This is done in a fat tree network, in which each node in the tree (except at the top level) has more than one parent.

The Figure 10.10 shows a fat tree in which each node has two parents.

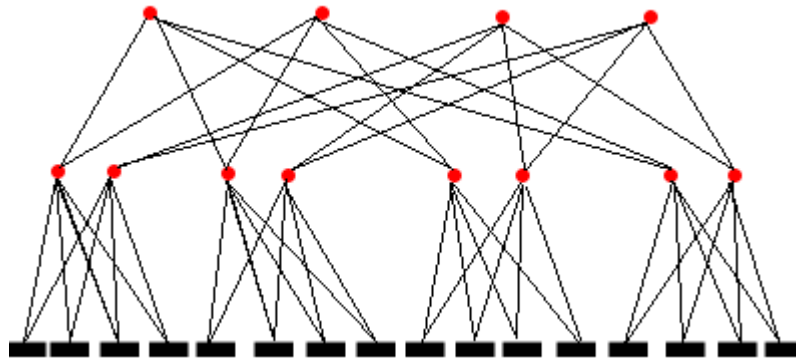

Figure 10.10: A Fat Tree

One of the simplest network topologies uses a ring to interconnect the nodes in the system. A single ring is shown in the Figure 10.11.

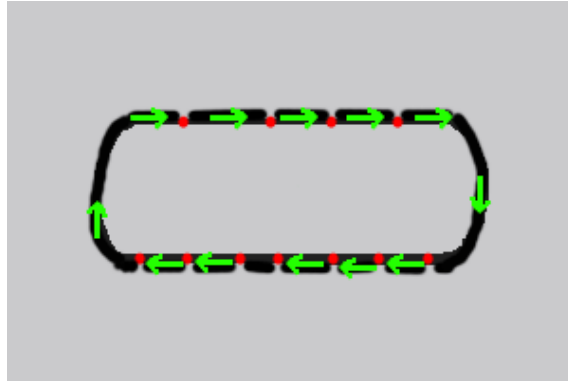

Figure 10.11: A Single Ring

The main advantage of the arrangement is that the ring is easy to implement. Links in the ring can be wide, because each node is connected to only two neighbors. It is not useful to construct a very long ring to connect many nodes because the latency of information transfer would be unacceptably large

The simple possibility of using ring in a tree structure; this results in a hierarchy of rings. A hierarchy of rings is shown in the Figure 10.12. Having short rings reduces substantially the latency of transfers that involve nodes on the same ring. The latency of transfers between two nodes on different rings is shorter than if a single ring were used.

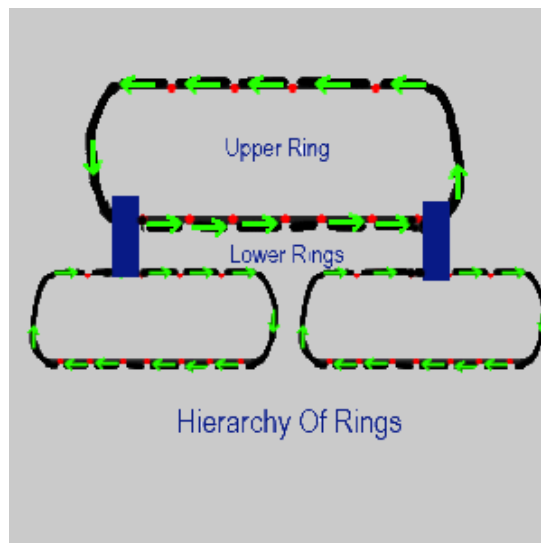

Figure 10.12: Hierarchy of Rings



Check your progress I

1. Execution of several activities at the same time.
 - a) processing
 - b) parallel processing
 - c) serial processing
 - d) multitasking
2. A term for simultaneous access to a resource, physical or logical.
 - a) Multiprogramming
 - b) Multitasking
 - c) Threads
 - d) Concurrency
3. _____ leads to concurrency.
 - a) Serialization
 - b) Parallelism
 - c) Serial processing
 - d) Distribution

16.3 Cache Coherence

In contemporary multiprocessor system, it is customary to have one or two levels of cache associated with each processor. This organization is essential to achieve high performance.

Cache creates a problem, which is known as the cache coherence problem. The cache coherence problem is: Multiple copies of the same data can exist in different caches simultaneously, and if processors are allowed to update their own copies freely, an inconsistent view of memory can result.

There are two write policies:

- Write back: Write operations are usually made only to the cache. Main memory is only updated when the corresponding cache line is flushed from the cache.
- Write through: All write operations are made to main memory as well as to the cache, ensuring that main memory is always valid.

It is clear that a write back policy can result in inconsistency. If two caches contain the same line, and the line is updated in one cache, the other cache will unknowingly have an invalid value. Subsequently read to that invalid line produce invalid results.

Even with the write through policy, inconsistency can occur unless other cache monitor the memory traffic or receive some direct notification of the update.

For any cache coherence protocol, the objective is to let recently used local variables get into the appropriate cache and stay there through numerous reads and write, while using the protocol to maintain consistency of shared variables that might be in multiple caches at the same time.

Write through protocol

A write through protocol can be implemented in two fundamental versions.

- Write through with update protocol
- Write through with invalidation of copies

Write through with update protocol

When a processor writes a new value into its cache, the new value is also written into the memory module that holds the cache block being changed. Some copies of this block may exist in other caches, these copies must be updated to reflect the change caused by the write operation. The simplest way of doing this is to broadcast the written data to all processor modules in the system.

As each processor module receives the broadcast data, it updates the contents of the affected cache block if this block is present in its cache.

Write through with invalidation of copies

When a processor writes a new value into its cache, this value is written into the memory module, and all copies in the other caches are invalidated. Again, broadcasting can be used to send the invalidation requests through the system.

Write back protocol

In the write-back protocol, multiple copies of a cache block may exist if different processors have loaded (read) the block into their caches. If some processor wants to change this block, it must first become an exclusive owner of this block.

When the ownership is granted to this processor by the memory module that is the home location of the block. all other copies, including the one in the memory module, are invalidated. Now the owner of the block may change the contents of the memory.

When another processor wishes to read this block, the data are sent to this processor by the current owner. The data are also sent to the home memory module, which requires ownership and updates the block to contain the latest value.

There are software and hardware solutions for cache coherence problem.

Software solution

In software approach, the detecting of potential cache coherence problem is transferred from run time to compile time, and the design complexity is transferred from hardware to software

On the other hand, compile time software approaches generally make conservative decisions, leading to inefficient cache utilization.

Compiler-based cache coherence mechanism perform an analysis on the code to determine which data items may become unsafe for caching, and they mark those items accordingly. So, there are some non-cacheable items, and the operating system or hardware does not cache those items.

The simplest approach is to prevent any shared data variables from being cached.

This is too conservative, because a shared data structure may be exclusively used during some periods and may be effectively read-only during other periods.

It is only during periods when at least one process may update the variable and at least one other process may access the variable then cache coherence is an issue.

More efficient approaches analyze the code to determine safe periods for shared variables. The compiler then inserts instructions into the generated code to enforce cache coherence during the critical periods.

Hardware solution

Hardware solution provides dynamic recognition at run time of potential inconsistency conditions. Because the problem is only dealt with when it actually arises, there is more effective use of caches, leading to improved performances over a software approach. Hardware schemes can be divided into two categories: (a) directory protocol and (b) snoopy protocols.

(a) Directory protocols

Directory protocols collect and maintain information about where copies of lines reside. Typically, there is a centralized controller that is part of the main memory controller, and a directory that is stored in main memory.

The directory contains global state information about the contents of the various local caches.

When an individual cache controller makes a request, the centralized controller checks and issues necessary commands for data transfer between memory and caches or between caches themselves.

It is also responsible for keeping the state information up to date, therefore, every local action that can affect the global state of a line must be reported to the central controller.

The controller maintains information about which processors have a copy of which lines.

Before a processor can write to a local copy of a line, it must request exclusive access to the line from the controller.

Before granting this exclusive access, the controller sends a message to all processors with a cached copy of this time, forcing each processor to invalidate its copy.

After receiving acknowledgement back from each such processor, the controller grants exclusive access to the requesting processor.

When another processor tries to read a line that is exclusively granted to another processors, it will send a miss notification to the controller.

The controller then issues a command to the processor holding that line that requires the processors to do a write back to main memory.

Directory schemes suffer from the drawbacks of a central bottleneck and the overhead of communication between the various cache controllers and the central controller.

(b) Snoopy protocols

Snoopy protocols distribute the responsibility for maintaining cache coherence among all of the cache controllers in a multiprocessor system. A cache must recognize when a line that it holds is shared with other caches.

When an update action is performed on a shared cache line, it must be announced to all other caches by a broadcast mechanism.

Each cache controller is able to "snoop" on the network to observed these broadcasted notifications and react accordingly.

Snoopy protocols are ideally suited to a bus-based multiprocessor, because the shared bus provides a simple means for broadcasting and snooping.

Two basic approaches to the snoopy protocol have been explored: Write invalidates or write-update (write-broadcast).

- i. **Write invalidates:** With a write-invalidate protocol, there can be multiple readers but only one write at a time. Initially, a line may be shared among several caches for reading purposes. When one of the caches wants to perform a write to the line it first issues a notice which invalidates the line in the other caches, making the line exclusive to the writing cache. Once the line is exclusive, the owning processor can make local writes until some other processor requires the same line.
- ii. **Write update (write broadcast):** With a write update protocol, there can be multiple writers as well as multiple readers. When a processor wishes to update a shared line, the word to be updated is distributed to all others, and caches containing that line can update it.



Check your progress II

1. For which shared (virtual) memory systems is the snooping protocol suited?
 - a. Crossbar connected systems
 - b. Systems with hypercube network
 - c. Systems with butterfly network
 - d. Bus based systems
2. Which MIMD systems are best scalable with respect to the number of processors?

- a. Distributed memory computers
 - b. ccNUMA systems
 - c. nccNUMA systems
 - d. Symmetric multiprocessors
3. The cost of a parallel processing is primarily determined by
 - a. Time Complexity
 - b. Switching Complexity
 - c. Circuit Complexity
 - d. None of the above
 4. In shared address space platform ensuring that concurrent operations on multiple copies of the same memory word have well-defined semantics is called_____.
 5. The maximum number of edges mapped onto any edge in E' is called the _____ of the mapping.

16.4 Summary

1. Parallel processing is a method in computing of running two or more processors (CPUs) to handle separate parts of an overall task.
2. Time shared bus is the simplest mechanism for constructing a multiprocessor system.
3. The multiport memory approach allows the direct, independent access of main memory modules by each processor and I/O module.
4. In NUMA architecture, all processors have access to all parts of main memory using loads and stores.
5. In a multiprocessor system, the interconnection network must allow information transfer between any pair of modules in the system.
6. A scheme known as the split- transaction protocol makes it possible to use the bus during the idle period to serve another request.
7. The main limitation of a single bus is that the number of modules that can be connected to the bus is not that large. Networks that allow multiple independent

transfer operations to proceed in parallel can provide significantly increased data transfer rate.

8. A bus-based network is perhaps the simplest network consisting of a shared medium that is common to all the nodes. A bus has the desirable property that the cost of the network scales linearly as the number of nodes, p .
9. In a star-connected network, one processor acts as the central processor. Every other processor has a communication link connecting it to this processor.
10. The cache coherence problem is: Multiple copies of the same data can exist in different caches simultaneously, and if processors are allowed to update their own copies freely, an inconsistent view of memory can result.
11. In multistage network, multiple stages of switches are used to setup a path between source and destination.
12. The protocols used in cache coherence system are (a) Invalidate protocol and (b) Update protocol.
13. Snoopy protocols distribute the responsibility for maintaining cache coherence among all of the cache controllers in a multiprocessor system.

16.5 Model Questions

1. What do you mean by parallel processing?
2. What are the classifications of systems with parallel processing capabilities given by Flynn?
3. What are the basic characteristics of symmetric multiprocessor (SMP)?
4. What do you mean by tightly coupled multiprocessor?
5. What are the basic features of time-shared bus?
6. What is multi-port memory and how its is used in multiprocessor systems?
7. What are the differences among UMA, NUMA and CC-NUMA?
8. Explain the concept of crossbar network.
9. What is multistage network?



Answers to Check your progress I

1. b
2. d
3. b



Answers to Check your progress II

1. d
2. a
3. c
4. cache coherence
5. congestion

Reference

Addressing mode. (2020, June 12). Retrieved from https://en.wikipedia.org/wiki/Addressing_mode available under the Creative Commons Attribution-ShareAlike License;

Burch, C. (2020, June 08). *The hierarchy of memory & caches.* Retrieved from www.toves.org: <http://www.toves.org/books/cache/> available under a Creative Commons Attribution-Share Alike 3.0 United States License.

Deka, J. K. (2009, Dec. 31). *Computer Organization and Architecture.* Retrieved from <https://nptel.ac.in/courses/106/103/106103068/> available under Creative Commons Attribution-NonCommercial-ShareAlike license.